

Connectionist Taxonomy Learning

Inaugural-Dissertation
zur
Erlangung der Doktorwürde
der
Philosophischen Fakultät
der
Rheinischen Friedrich-Wilhelms-Universität
zu Bonn

vorgelegt von
Miłosław L. Frey
aus Kraków

Bonn, 2007

Gedruckt mit der Genehmigung der Philosophischen Fakultät
der Rheinischen Friedrich-Wilhelms-Universität Bonn

Zusammensetzung der Prüfungskommission

Herr PD Dr. Bernhard Schröder

(Vorsitzender)

Herr Prof. Dr. Winfried Lenders

(Betreuer und Gutachter)

Herr PD Dr. Ulrich Schade

(Gutachter)

Herr Prof. Dr. Wolfgang Hess

(weiteres prüfungsberechtigtes Mitglied)

Tag der mündlichen Prüfung: 3. Mai 2007

Diese Dissertation ist auf dem Hochschulschriftenserver der ULB Bonn
http://hss.ulb.uni-bonn.de/diss_online elektronisch publiziert

Miłosław L. Frey

Connectionist Taxonomy Learning

I don't want knowledge, I want certainty
I don't want knowledge, I want certainty
Oh I get a little bit afraid
Sometimes

David Bowie
Law (Earthlings on Fire), 1997

Introduction

Categorization is one of the most common phenomena one has to deal with during one's lifetime. Whatever action we have to take, the categorization is a preassumption. Categorization is not only connected to sensual experiences, like, for example, perceiving colors or sounds, but also deals with our activities. Moreover, each mental system human is able to create, has a notion of categorization. In linguistics, for example, categories emerge on each language level: from phonetics to pragmatics. Categorization is thus fundamental in all kinds of interaction with the world.

Although categorization is so important to us, it is one of the least known and least understood processes. It has been a long time since scientists started to investigate the categorization

process and to model it — in my opinion still without really convincing results.

With this work I would like to contribute to the investigation of categorization. I am far from stating that my model is the best, or even better than what was already done. However, I would like to present it as an anchor point for further investigations, because I believe that my ideas contain some potential to challenge several current problems in cognitive sciences.

The tool used to implement my model is based on a connectionist paradigm. However, I would not like to contribute to the eternal opposition between localist versus distributed branches of connectionism. In my opinion, there is no “black or white”. Instead, there is no possibility to use either pure localist or pure distributed formalism in more complex systems (even if their inventors state so). That is why my model tries to incorporate aspects of both flavors of connectionism.

The model of categorization presented here is of course not the ultimate way to describe this process. In the present stage it focuses on the creation of the hierarchy (taxonomy) of concepts in an easily readable way. I would not like to state that it is able to model real cognitive processes. Instead my aim was to create a formal but usable way to describe them. I hope that it can help in understanding them and at the same time it will create a framework for applications. The most obvious is automatic classification of different items, and thus supporting the lexicon creation within

more sophisticated computer-linguistic applications. As a further application, my model can serve as a base to create full (or at least more developed) ontologies in different domains of computer and language sciences.

Outline

This work is divided as follows. The first part deals with theoretical issues. In Chapter 1 the terms category, categorization and taxonomy are introduced in the context of this work. Further, categorization models proposed in the literature (Chapter 2) as well as basics of connectionism (Chapter 3) are described. The second part goes into details of the model proposed here. Chapter 4 explicates the architecture of a single node as well as of the whole network, followed by Chapter 5 that presents details of the implementation of the model. The following Chapter 6 presents several experiments conducted with the use of the model in question and compares the results against real psychological experimental data. Chapter 7 summarizes the description of the model itself, whereas Chapter 8 closes this work with conclusions. Additionally, two

appendices (Appendix A and B) present central elements of Java and *dot* source code as implemented in order to evaluate the model presented.

Contents

I	Theory	19
1	Categories, Categorization and Taxonomies	21
1.1	Category	22
1.1.1	Aristotle	22
1.1.2	Immanuel Kant	23
1.1.3	Category in this work	24
1.2	Where do categories come from?	26
1.3	Taxonomies	26
2	Models of Categorization	29
2.1	The Classical Model	32
2.1.1	Feature Model in Phonology	33

2.1.2	Feature Model in Other Linguistic Fields . . .	34
2.1.3	Feature Model and Language Acquisition . . .	37
2.2	Non-Classical Models	38
2.2.1	Rosch’s “Standard” Prototype Model	40
2.2.2	Family Resemblance	53
2.2.3	Exemplar-Based Model	57
2.3	No Clear-Cut Between Models	58
2.4	Learning Categories	59
3	Connectionism	63
3.1	On the History of Connectionism	65
3.2	Algorithmic Model Theory	68
3.3	Remarks on Data Representation	69
3.3.1	Localist Data Representation	70
3.3.2	Distributed Data Representation	71
3.3.3	Meaning of a Unit	71
3.3.4	Semantic Problems	72
3.4	Distributed Connectionism	73
3.4.1	The Artificial “Neuron”	74
3.4.2	Basic Architecture	77
3.4.3	Learning	78
3.4.4	Self-Organizing Maps	81
3.5	Localist Connectionism	85
3.5.1	Theory of Retrieval in Sentence Production	86

3.5.2	Spreading Activation and Language Production	87
3.5.3	Aphasia Model	88
3.5.4	Connectionist Speech Production	89
3.6	Semantic Networks	89
3.6.1	Concepts	90
3.6.2	Semantic Network	92
3.7	Connectionism vs. Brain Structure	102
3.8	Connectionism and Language Processing	104
3.9	My Categorization Model and Connectionism	105

II Practice 107

4 Architecture and Operation of the Model 109

4.1	A Node	110
4.2	Activation Spreading	113
4.2.1	Signals from Parent Nodes.	113
4.2.2	Signals from Child Nodes	120
4.2.3	Final Activation Function	120
4.2.4	Implementation	122
4.3	Connections	122
4.4	Learning	123
4.4.1	Concept Learning	126
4.4.2	Introspective Processes	128

5	Implementation	131
5.1	Objectives	131
5.2	Realization	132
5.2.1	Nodes	133
5.2.2	Network	134
5.2.3	Network visualization	134
5.3	Summary	135
6	Evaluation	137
6.1	Introductory Simulation: Creating a Taxonomy . .	139
6.1.1	Training Data	139
6.1.2	Storing the Data	140
6.1.3	Creating a Hierarchy	142
6.1.4	Network Pruning	144
6.1.5	Discovery	145
6.1.6	Final Network	148
6.1.7	Summary	149
6.2	Introductory Simulation: Autoassociation	150
6.2.1	Preparing a Network	150
6.2.2	Autoassociation Process	151
6.3	Introductory Simulation: Generalization	154
6.4	Cup or Bowl: Fuzzy Categorization	157
6.4.1	Original Experiment	160
6.4.2	Simulation	162
6.5	Cats Could Be Dogs	169

6.5.1	Original Experiment	169
6.5.2	Simulation	170
7	Model Properties	177
7.1	Description Autocompletion and Noise Reduction .	177
7.2	Generalization	178
7.2.1	Overfitting	179
7.3	Family Resemblance	180
7.4	Fuzzy Categorization	181
7.5	Priming	182
7.6	Lexical Items	183
7.7	Asymmetric Category Learning	184
7.8	Localism and Distributionism	185
7.8.1	Comparison against PDP-networks	187
7.9	Biological Inspiration	188
8	Conclusions	191
	Bibliography	195
A	Implementation of the Central Algorithm Parts	223
A.1	Activation from Parent Nodes	223
A.2	Activation from Child Nodes	224
A.3	Final Activation	225
B	Example <i>dot</i> description of a network	227

List of Figures

2.1	Clark's hierarchical features setup.	37
2.2	Two axes of categorization.	42
2.3	Farmers' classification of leaf feeding insects in Leyte, Philippines	46
2.4	The radial structure of category.	54
2.5	The non-radial structure of category.	55
3.1	Hierarchy of different cognitive models.	65
3.2	Rosenblatt's perceptron.	66
3.3	Local and distributed data representation.	70
3.4	An artificial neuron.	75
3.5	Sigmoidal (standard logistic) function.	76
3.6	Multi-layer perceptron schema.	78

3.7	WebSOM example.	83
3.8	An example of a dendrogram	84
3.9	The meaning triangle.	91
3.10	Tree of Porphyry.	95
3.11	A sophisticated semantic network	97
3.12	Hierarchical semantic memory model by Collins and Quillian (1969).	98
3.13	Spreading activation network in the tradition of Collins and Loftus (from Collins and Loftus, 1975, p. 412).	99
3.14	A propositional network representing a structure on the sentence level.	100
3.15	A simple KL-ONE network of generic concepts (from Brachman and Schmolze, 1985, p. 180).	101
3.16	A network representing a sentence in KL-ONE (from Brachman and Schmolze, 1985, p. 214).	102
3.17	A neuron	103
4.1	Internal structure of a node.	112
4.2	Two sample nodes in 2D phase space.	114
4.3	Example Gaussian functions	118
5.1	Class diagram. Only the most relevant fields and methods are shown.	136
6.1	Raw input data presented as a network structure. .	143
6.2	The incorrect class—superclass connection	144

6.3	Detecting incorrect class—superclass connection . . .	146
6.4	The form of a network after the discovery procedure.	148
6.5	The final form of a network: the taxonomical structure.	149
6.6a	Starting network for autoassociation demonstration.	152
6.6b	First step of autoassociation: activating some nodes.	155
6.6c	Successful autoassociation	156
6.7a	Starting point for generalization process.	158
6.7b	Successful autoassociation in case of contradicting features.	159
6.8	Drawings used for simulation of Labov’s experiment.	162
6.9	Results of simulation of Labov’s experiment (neutral context).	166
6.10	Results of simulation of Labov’s experiment (food context).	167
6.11	Original figure from Labov (1974).	168
6.12	Result of “cats and dogs” experiment.	175

List of Tables

2.1	Different prototypical objects.	53
6.1	Data for introductory simulation.	141
6.2	Data for autoassociation simulation.	151
6.3	Data used for simulation of Labov’s experiment. . .	163
6.4	Results of simulation of Labov’s experiment (neutral context).	166
6.5	Results of simulation of Labov’s experiment (food context).	167
6.6	Data for cats in “cats and dogs” experiment. . . .	171
6.7	Data for dogs in “cats and dogs” experiment. . . .	172

Part I

Theory

CHAPTER 1

Categories, Categorization and Taxonomies

Categories and categorization are one of the most important concepts in one's life. Usage of categories is usually not noticed, but precedes many other activities. Categorization is a process which prepares people to take any action by assigning received signals and actions to be performed to different sets of equivalent entities. Thanks to this process, it is possible to store and manage an infinite number of stimuli and possible actions taking place in the real world. Although everybody has a feeling of what *category* and *categorization* mean, the exact meanings of these terms are discussable and are indeed defined differently by different authors (cf. below). Therefore, this chapter briefly introduces the

meaning of these terms as used further in this work.

1.1 Category

The term category comes from the Greek word *κατηγορία* which means “assertion” or “accusation”. In the following, I present some views on categories and category systems. They can be regarded as milestones on the way to understanding a category, as used in this work.

1.1.1 Aristotle

The first systematic work on categories is the Aristotelian text “Categories” (Aristotle, 1928). Aristotle begins with the definition of equivocality, univocality and derivativeness. These three terms are then used to describe relations between objects and thereby also their belonging to a given group of objects.

According to Aristotle, each atomic thing (that means a thing without a further internal structure) or a living being can be attributed one of ten characteristics: substance, quantity, quality, relation, action, affection, place, time, position or state. In Aristotle’s view these characteristics are inherent.

“To sketch my meaning roughly, examples of substance are ‘man’ or ‘the horse’, of quantity, such terms as ‘two cubits long’ or ‘three cubits long’, of quality, such attributes as ‘white’, ‘grammatical’. ‘Double’, ‘half’,

‘greater’, fall under the category of relation; ‘in a market place’, ‘in the Lyceum’, under that of place; ‘yesterday’, ‘last year’, under that of time. ‘Lying’, ‘sitting’, are terms indicating position, ‘shod’, ‘armed’, state; ‘to lance’, ‘to cauterize’, action; ‘to be lanced’, ‘to be cauterized’, affection.” (*Categories*, Chap. 4 Aristotle, 1928)

These attributes define ten main categories for every item in the world: a system of categories which forms a list of the highest genera of things. A complete system of categories in the Aristotelian spirit would offer a systematic inventory of everything that exists, considered at the most abstract level.

1.1.2 Immanuel Kant

Skepticism about the ability to extract inherent properties of objects, thus defining intrinsic divisions of reality, led to the next step in understanding categories which was made by Kant in his “*Kritik der reinen Vernunft*” (Kant, 1787/1990). He denied this ability to access the internal world’s structure but believed that one can discover our categories of understanding. Thus, the main question he tried to answer in the abovementioned work was how much can experience support understanding. Obviously, to answer this question one has to discover the fundamental types of subjective understanding which organize perceptions into knowledge.

“Wenn wir von allem Inhalte eines Urteils überhaupt abstrahieren, und nur auf die bloße Verstandesform darin achtgeben, so finden wir, daß die Funktion des Denkens in demselben unter vier Titel gebracht werden können, deren jeder drei Momente unter sich enthält. Sie können füglich in folgender Tafel vorgestellt werden.

1. Quantität der Urteile: Allgemeine; Besondere; Einzelne
2. Qualität: Bejahende; Verneinende; Unendliche
3. Relation: Kategorische; Hypothetische; Disjunktive
4. Modalität: Problematische; Assertorische; Apodiktische”

(Kant, 1787/1990, §9)

These twelve modes define concepts of understanding which Kant calls “categories” (1787/1990, §10). For Kant, the categories are a priori and transcendental. They are used for making judgments which constitute preconditions for principles of understanding nature.

1.1.3 Category in this work

For the purpose of this work, a category is defined in a simple way which summarizes the common components of Aristotle’s and

Kant's category systems, and simultaneously agrees with the common understanding of this term. Category is defined here as an imaginary container, that contains all objects which are similar to each other and simultaneously different to objects from other categories (containers).

However, unlike in most philosophers' works, the number and type of categories or characteristics which lead to assigning a category cannot be defined, because the goal of the investigations presented here is not to find a unique answer to the ontological question of what kinds of universal genera exist. Thus, the number of categories in the system presented here is neither defined nor limited. It also means that categories are not given a priori but emerge from experience.

One must note that there are several ways to "measure" the similarity of objects. These methods actually define the models of categorization. Aristotle and Kant used intrinsic properties of objects or modes of understanding to assign any item into one category. The way to measure the similarity which I use in the system presented here is also based on properties (here also referred to as *features*), but these features are treated in a more flexible way, and – even more important – they can be graded and may contain intermediate states. The most important models of categorization which developed from the Aristotelian yes/no method to the modern psychologically based ones are described in the following chapter 2.

1.2 Where do categories come from?

Categories are not completely arbitrary. One can find many clues in the world that give the basis for categorization.

The world is structured because real-world attributes do not occur independently of each other. (...) That is, combinations of attributes of real objects do not occur uniformly. Some pairs, triples, or n-tuples are quite probable, appearing in combination sometimes with one, sometimes with another attribute; others are rare; others logically cannot or empirically do not occur. (Rosch et al., 1976)

This means that not only the pure characteristic of a given object is necessary. The most important thing is the cooccurrence of properties. As a consequence, the analysis of clusters of features can lead to the discovery of a category.

A process of categorization does not only mean finding similarities between instances of the given class. It is also searching for differences to instances of other classes. Those differences help in creating characteristics of a given category.

1.3 Taxonomies

Categorization, that is, finding categories in unstructured data, is here regarded as a synonym of classification. The classification

in hierarchical systems is building a taxonomy (from greek $\tau\alpha\xi\omicron\zeta$ “arrangement, order” and $-\nu\omicron\mu\iota\alpha$ “method”). Thus a taxonomy is a method of arrangement or a method of ordering.

Taxonomies are hierarchical arrangements of objects (things, concepts etc.) displaying usually parent-child relationships. The parent-child relationship, also referred to as *is-a* or subsumption relationship, is in the main scope of this work. Hierarchical taxonomies are tree structures with a single root node (top node) that applies to all objects in the hierarchy.

The aim of the work presented here is the construction and evaluation of a system that creates a taxonomical tree structure emerging from the previously unstructured input data and therefore performs categorization automatically. The system consists of logical nodes which are analogue to taxonomical units and connections which define the relations between nodes. In the course of operation, this system of nodes organizes itself into a taxonomical tree structure – the hierarchy – which reproduce the relations between objects represented by the nodes.

CHAPTER 2

Models of Categorization

Categorization is one of the most important cognitive processes.

“There is nothing more basic than categorization to our thought, perception, action, and speech. Every time we see something as a *kind* of thing, (...) we are categorizing. Whenever we reason about *kinds* of things (...) we are employing categories. Whenever we intentionally perform any *kind* of action, (...) we are using categories.” (Lakoff, 1987, p. 5)

Categorization creates a framework for the interpretation of experiences. Its goal is to group individual entities by neglecting

subtle differences in individual experiences when they are not necessary. Without categorization the world would seem constantly changing and thus probably impossible to explore (cf. Smith and Medin, 1981). It is important to realize that although categorization is usually performed unconsciously and without noticeable effort it is nevertheless a process which has to be learned. Even more, the categories themselves are not innate and must be acquired from experience.

Especially in linguistics – in phonology, in morphology and syntax as well as in semantics – categorization is a process of high value. In linguistics, categorization is used at two levels (Taylor, 2001): to describe the subject of its exploration and also to interrelate linguistic terms to the real world. Language components can be classified not only according to their formal structure or membership in specific groups of grammatical entities but also as labels for phenomena encountered in real world. For example, the term *red* is not only an instantiation of the word class “adjective” but also denotes a bundle of visual experiences.

Labov (1974) points out that this preferential reputation of categorization often moves away from scope the understanding of the nature of categories:

“The categorization is such a fundamental part of linguistic activity that the properties of categories are normally assumed rather than studied.” (p. 342)

As an interesting example of the above statement, one can quote the Whorf's principle of linguistic determinism (cf. Gipper, 1972). Whorf assumed that categories used by people are given along with the language they use, and as such, they split the world according to the concepts expressed by a language.

“We dissect nature along lines laid down by our native languages. The categories and types that we isolate from the world of phenomena we do not find there because they stare every observer in the face; on the contrary, the world is presented in a kaleidoscopic flux of impressions which has to be organized by our minds – and this means largely by the linguistic systems in our minds. We cut nature up, organize it into concepts, and ascribe significances as we do, largely because we are parties to an agreement to organize it in this way – an agreement that holds throughout our speech community and is codified in the patterns of our language. (...) All observers are not led by the same physical evidence to the same picture of the universe, unless their linguistic backgrounds are similar, or can in some way be calibrated.” (Whorf, 1956, p. 213-214)

However, to understand the linguistic as well as psychological processes of categorization it is important to know what a category is and how it can be defined. Moreover, the discovery of a structure of categories and dependencies between them is also

significant. To tackle these problems there has to exist a model of categorization and categories.

This chapter presents an overview over different models of categorization. It starts with the classical one which formed a base for language analysis in the twentieth century. In contrast to this view, models based on new psychological and linguistic findings have arisen. The prototype and exemplar based models, to name the most prominent ones, are described here to illustrate efforts to overcome the limitations of the classical model.

2.1 The Classical Model

The classical view on categorization has its origin in works of Aristotle (1928, 1908). Aristotle defines the category membership on the base of the following assumptions.

- Categories are defined by a set of necessary and jointly sufficient rules based on features.
- Features have binary nature. This means they may be either present or not. This is a consequence of a rule that something has either to exist or not, and everything either posses a certain feature or not.
- Thus categories have well defined and sharp borders and are disjunctive. There are no objects which belong partially to some category or which belong to more than one category.

- All elements of categories are equally good because they are defined by the same set of binary features, shared by all members.

The Aristotelian way of defining categories strongly influenced the linguistics of the twentieth century. It forms a base for many theories in phonology as well as in syntax and semantics.

2.1.1 Feature Model in Phonology

Probably the most spectacular success the classical view celebrated, was with respect to phonology, which defines speech as a set of phonemes. Phonemes are described by a set of features. According to Chomsky and Halle (1968) the binary nature of phonological features is important because they are used for classification. Using the “yes/no mechanism” is a natural method to show whether a unit in question is a member of a given category or not.

The noteworthy success of Aristotelian feature-based mechanism inclined many phonologists to develop it further, and to enrich the properties of phonological features by additional assumptions:

- Features are primitive, i.e., they have no internal structure and cannot be decomposed further.
- Features are universal. All phoneme classes are defined by a set of features common to all languages which express human articulation ability.

- Features are abstract. They do not describe directly any physical phenomena related to speech production or comprehension but they appear only as a classificatory markers (in contrast to the phonetic features that range over a full scale of physical phenomena, cf. Chomsky and Halle, 1968, chapter 7).
- Sometimes it is also postulated that phonological features are innate. This is a consequence of the two latter characteristics: if they are really universal and abstract, they cannot be acquired from physical data, so there is no possibility for children to learn them. Thus, they must be innate.

2.1.2 Feature Model in Other Linguistic Fields

A classification theory based on the assumptions listed above was very productive in phonology and this success probably encouraged scientists to use it analogously also in other linguistic fields like phonetics, syntax, and semantics.

Analogous to phonologist findings, a systematic description in phonetic was developed. It describes sounds in a well organized manner, by means of phonetic units (Laver, 1994; Clements and Hume, 1995). *Phonetic features* (Ladefoged, 1975; Lindau, 1978) constitute a minimum set of the descriptive parameters used to distinguish among different phonetic units. The set of all features forms a model of a language and its structure. According to the perception domain, there exist several types of phonetic features:

- articulatory features, defined in terms of the action of the organs of speech,
- acoustic features, defined in terms of the physical properties of the speech sound relevant to the feature, and
- perceptual features, defined in terms of the perception of the given sound by the ear and the brain.

A relatively constant set of phonetic features builds up a phonetic segment. A given feature may be limited to a particular segment but may also be longer (suprasegmental) or shorter (subsegmental). Among segments there are phonological units of the language, such as vowels and consonants.

A description of coarticulation can be quoted as a success of feature based approach in phonetics. Coarticulation is a process of the assimilation of the place of articulation of one speech sound to that of an adjacent speech sound. The feature based model accounting for explanation of coarticulation uses so-called “feature spreading” (cf. Daniloff and Hammarberg, 1973; Lubker, 1981). In this model, each articulatory segment is characterized by a set of features. On the input level only contrasting features are specified and irrelevant properties are not being defined. The coarticulation is then regarded as spreading a feature’s value from a given segment to the nearby segment.

The *structural analogy assumption* (Anderson and Durand, 1986; Anderson, 1992) underlies the usage of similar principles

and methods in exploring the nature of syntactic and semantic structures:

“The relevance of dependency throughout the linguistic description is in accordance with what has been called the STRUCTURAL ANALOGY assumption. (...) This is simply the assumption, familiar from much post-Saussurean work, that we should expect that the same structural properties recur at different levels. Structural properties which are postulated as being unique to a particular level are unexpected and suspicious if unsupported by firm evidence of their unique appropriateness in that particular instance.”
(Anderson and Durand, 1986, p. 3)

Despite its drawbacks, according to Kleiber (2003), the classical view on categorization is justified psychologically. It reflects the fact that the meaning of the word (the category it denotes) is something more or less well defined. Usually categories are seen as distinct and non-overlapping units. The classical view originates from the so-called *folk theory of categorization* which is consistent with philosophical tradition (Aristotle) on which the classical view is based. Although Lakoff (1987) argues that folk categorization does not reflect reality, it is based on the common-sense intuition that there must exist some sets of features that allow for distinguishing between different categories, that those categories are well-defined and form a taxonomy.

2.1.3 Feature Model and Language Acquisition

The classical feature-based view on categorization was also utilized to model language acquisition by infants and children.

One of the prominent trials in this field was a hypothesis formulated by Clark (1973) based on semantic features. In her hypothesis, Clark postulated that the meaning of the word is learned in early childhood by acquiring semantic features. The first assimilated features are the most general ones, and come from perceptual experiences of children, and thus the categorization of the world results from sensual perception. In the further development of language, the meaning of words is refined by adding more and more specific semantic features.

Clark states that this hypothesis is especially applicable for learning pairs of words with opposite meanings (antonyms). In these cases, the hierarchical structure (figure 2.1) of learned features leads to gradual refining of the meaning.

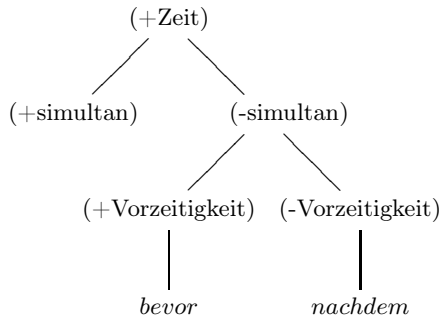

Figure 2.1: Clark's hierarchical features setup (after Szagun, 1996).

The explanation of learning the meaning by acquiring semantic features from perceptual experience is, however, not sufficient. One of the unclarities was the way how sensual experiences can change into abstract semantic features. Moreover, the theory could not explain the meaning of words which cannot be expressed in terms of perception (like *animal* or *friendship*) (cf. Carey, 1982; Szagun, 1983).

Finally, other empirical studies showed that Clark's hypothesis can be applied to explain only few special cases of meaning acquisition, namely in case of contrasting words. When the set of words to disambiguate was broader (i.e. not limited to contrasting words), the experiments (cf. Kavanaugh, 1976; Wannemacher and Ryan, 1978) showed that if a child did not understand a given word (e.g. *before*), it did not necessarily imply that it had the opposite meaning (e.g. *after*).

2.2 Non-Classical Models

The classical view of categorization outlined so far was challenged in the twentieth century by many philosophers and psychologists. Some drawbacks of the classical view were spotted by Wittgenstein (1971). He analyzed a category of games, and came to the conclusion that not only there are no common features to all games but also some games are considered as better members of the category than others.

„Betrachte z.B. einmal die Vorgänge, die wir “Spiele” nennen. Ich meine Brettspiele, Kartenspiele, Ballspiel, Kampfspiele, usw. Was ist allen diesen gemeinsam? – Sag nicht: “Es muß ihnen etwas gemeinsam sein, sonst hießen sie nicht »Spiele«” – sondern schau ob ihnen allen etwas gemeinsam ist. – Denn, wenn du sie anschaust, wirst du zwar nicht etwas sehen, was allen gemeinsam wäre, aber du wirst Ähnlichkeiten, Verwandtschaften, sehen, und zwar eine ganze Reihe. Wie gesagt: denk nicht, sondern schau! – Schau z.B. die Brettspiele an, mit ihren mannigfachen Verwandtschaften. Nun geh zu den Kartenspielen über: hier findest du viele Entsprechungen mit jener ersten Klasse, aber viele gemeinsame Züge verschwinden, andere treten auf. Wenn wir nun zu den Ballspielen übergehen, so bleibt manches Gemeinsame erhalten, aber vieles geht verloren. – Sind sie alle “unterhaltend”? Vergleiche Schach mit dem Mühlfahren. Oder gibt es überall ein Gewinnen und Verlieren, oder eine Konkurrenz der Spielenden? Denk an die Patienzen. In den Ballspielen gibt es Gewinnen und Verlieren; aber wenn ein Kind den Ball an die Wand wirft und wieder aufhängt, so ist dieser Zug verschwunden. Schau, welche Rolle Geschick und Glück spielen. Und wie verschieden ist Geschick im Schachspiel und Geschick im Ten-

nisspiel. Denk nun an die Reigenspiele: Hier ist das Element der Unterhaltung, aber wie viele der anderen Charakterzüge sind verschwunden! Und so können wir durch die vielen, vielen anderen Gruppen von Spielen gehen, Ähnlichkeiten auftauchen und verschwinden sehen.

Und das Ergebnis dieser Betrachtung lautet nun: Wir sehen ein kompliziertes Netz von Ähnlichkeiten, die einander übergreifen und kreuzen. Ähnlichkeiten im Großen und Kleinen.” (Wittgenstein, 1971, p. 48)

This analysis conducted by Wittgenstein illustrated that there exist casual categories, which cannot be described with the help of well-defined sets of features. Everyone knows what a game is, but it is not possible to characterize all games by means of naming what they all have in common. There exist only similarities and relationships among them.

Wittgenstein’s findings were further confirmed by many psychological investigations, most notably those conducted by Labov (1974), Rosch (1975a,b, 1988) or Lakoff (1973). The philosophical investigations as well as psycholinguistic experiments had shown that a model different from the classical one was needed.

2.2.1 Rosch’s “Standard” Prototype Model

The “standard” prototype model of categorization was formed by Rosch and her collaborators in the 1970s. Its main feature is the

redefinition of the internal structure of the category (“the horizontal dimension of categories”) as well as the differentiation between categories (“the vertical dimension”) without using the legacy of classical categorization theory.

Two main principles underlied the formation of a prototype model: cognitive economy and perceived world structure. They express the fact that (natural) categories are not a result of arbitrary considerations or of a historical accident but rather are motivated physiologically.

Cognitive Economy. The cognitive economy principle says that the categorization process should provide maximum information with minimum cognitive effort.

“To categorize a stimulus means to consider it, for purposes of that categorization, not only equivalent to other stimuli in the same category but also different from stimuli not in the category.” (Rosch, 1988, p. 28)

The categorization process should differentiate between objects only if those differences are relevant for a given task.

Perceived World Structure. Simple observations and common sense considerations lead to the conclusion that the world does not allow any arbitrary combinations of attributes or stimuli. Thus Rosch states that also categories and categorization processes are influenced by the world’s structure. Moreover, what is really im-

portant is *perceived* world structure, which can vary depending on the observer. There does not exist an arbitrary way of perception. What the world looks like and how it is structured are strongly dependent on who or what the subject of observation is. The world's image is completely different for humans and rattlesnakes, because both these creatures use different senses with different sensitivity.

The two principles above lead to the formation of a structure of categories. This structure is seen two dimensionally and spans on two axes: horizontal and vertical. The idea of axes of categorization is depicted on figure 2.2.

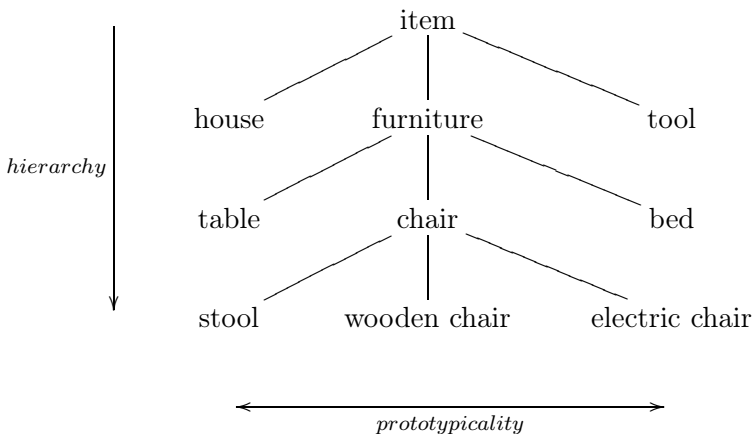

Figure 2.2: Two axes of categorization.

The Horizontal Dimension: Prototype

The horizontal dimension of categorization refers to the internal structure of categories. In Rosch's theory this structure is defined in terms of *prototypes*.

The idea of prototypical members of categories originates from the fact that not all members of a given category are equally good ones. The prototypical members are those that can be said better to represent a category better than others. In an experiment Rosch (1975a) investigated several categories like FURNITURE, FRUIT, VEHICLE and others. This experiment was conducted on about 200 American students. The subjects had to answer how well objects from prepared lists represent a given category. The students had to rate the objects in a seven-level scale. The results of this questioning were (according to Rosch) reliable from a statistical point of view and showed not only that graded category membership is a sensible idea but also that there exist objects considered as the best members of a given category. These ones Rosch called *prototypes*.

“By prototypes of categories we have generally meant the clearest cases of category membership defined operationally by people's judgments of goodness of membership in the category. (...) [T]he more prototypical of a category a member is rated, the more attributes it has in common with other members of the category

and the fewer attributes in common with members of the contrasting categories.” (Rosch, 1988, pp. 36–37)

Taylor (2001) mentions results obtained by René Dirven in a similar experiment conducted on German speaking students concerning the category MÖBEL. Interestingly, this experiment shows that although categories FURNITURE and MÖBEL are seen semantically equivalent, their internal structure is different: the most prototypical objects for category FURNITURE are *chair* and *sofa* while for category MÖBEL there are *bed* and *table*. This inter-language comparison shows that indeed the second principle of categorization, the perceived world structure, has great influence on a category’s structure formation which may vary for different nations and languages.

Using prototypes instead of necessary and sufficient conditions implies redefining the process of categorization. Objects have to be categorized not by analyzing conditions or sets of features, but by comparing them to the prototypical members. To be more precise, the prototypes are seen as the most typical members of a category and the other objects belong to this category if they are similar enough to the prototypes. The prototypes thus are *cognitive reference points* (Rosch, 1975a).

One has to note the difference between the terms *prototype* and *stereotype*, which I will explain as follows. Wierzbicka (1985) points out that:

“In ordinary language, the word prototype is usually used to refer to the original model of a certain kind of thing (‘the first thing or being of its kind; model’, Webster’s 1977). It is unfortunate, therefore, that in recent literature on meaning this word has been widely used, and in fact has become ‘institutionalized’, in a different sense, which would have been better served by the word stereotype.” (p. 80)

According to the tradition in linguistic literature, however, I will use the above terms after Schwarze (1985, p. 78):

“Nous appelons prototype l’objet qui est le meilleur exemplaire d’une catégorie, et stéréotype le concept qui le décrit”.

In other words,

“a prototype is an object which is held to be a very TYPICAL of the kind of object which can be referred to by an expression containing the predicate” (Hurford and Heasley, 2004, p. 85)

while a stereotype is

“a list of the TYPICAL characteristics of things to which the predicate may be applied” (Hurford and Heasley, 2004, p. 98).

Therefore, someone may have an idea of a stereotype without being able to find an appropriate example of it (a prototype).

The Vertical Dimension: Basic-Level Objects

The problem of assigning an object to a given category is connected to the vertical dimension of category systems. It is also a problem of category hierarchies (taxonomies). In a taxonomy, categories are related by means of inclusion.

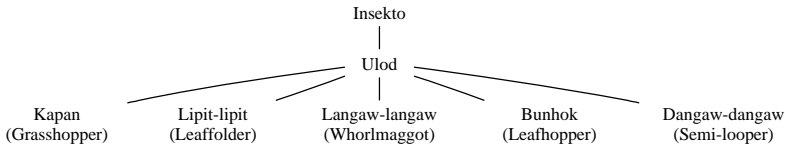

Figure 2.3: Farmers' classification of leaf feeding insects in Leyte, Philippines (adapted from <http://www.knowledgebank.irri.org/IPM/soccomm/>).

The ethnobiologist Brent Berlin examined the regularities in the classification and naming of plants and animals among peoples of traditional societies: So called *folk taxonomies* (see for example figure 2.3) have hierarchical levels similar to formal biological classifications of kingdom, phylum, class, order, family, genus and species. Berlin (1992) states that categories are related by inclusiveness and also that there is a preferential level of categorization: a basic level called *folk genus*. Folk genera often do not correspond to scientific genera, but, based on cultural tradition, serve as the most informative level in a given society.

The vertical structure of categories in Rosch's model emerges from the idea of folk genera. Within her model she has suggested three levels of categorization:

- superordinate,
- basic level, and
- subordinate.

The key word for learning hierarchy of categories in Rosch's model is the *basic-level* category. The experiment in which subjects had to list as many attributes as possible for objects in classes designated by names of categories from different levels was conducted. Similar experiments involved also listing of motor movements and comparison of simplified shapes of objects.

“For all the taxonomies studied, regardless of whether language dependent variables such as attributes or language independent variables such as shape were used, there was a level of abstraction at which all factors co-occurred and below which further subdivisions added little information.” (Rosch et al., 1976, p. 428)

Basic-level categories can thus be described as *information-rich bundles of co-occurring perceptual and functional attributes*. According to Kleiber (2003) their psycholinguistic importance manifests itself in many ways outlined below.

The basic-level is the highest level of abstraction where it is possible to construct a Gestalt of an object (Berlin, 1992). There is a general form of a *chair*, but no general form for *furniture*. This is directly connected to the fact that on the basic-level it is possible to create an image (abstract or concrete) representing the

whole category. Trying to create an image of an object from superordinate category one either ends up with an object which in fact belongs to a basic-level category or one is not able to accomplish this task at all.

Motoric movements (for categories to which they apply) are similar for all objects contained in basic-level (Rosch, 1988). And again, in the example mentioned above, it is possible to imagine or describe the process of *using a chair* while there is no general routine for *using furniture*.

From the purely psychological point of view, basic-level categories also manifest their existence in several ways (Rosch et al., 1976): In the task of categorization, assigning objects to basic-level category is faster than to other levels of abstraction. It results, among other things, in more frequent use of names of those objects in naming tasks. Directly connected with this phenomenon is the fact that basic-level categories are the first and fundamental categories learned by children.

The basic-level of categorization manifests itself also in language usage. Terms denoting objects on the basic-level are context neutral (cf. Cruse, 1977; Lakoff, 1987). They also usually define the choice of pronouns. Usage of super- or subordinate term is most often motivated by a context, while in context-neutral utterances people tend to choose basic-level terms.

The Importance of the Prototype Model

The most important consequence of the development of the prototype model was the creation of an alternative to the Aristotelian-like way of categorizing. It is of great importance to have other categorization models because, as mentioned above, the classical model does not explain psychological data gathered. Indeed, the prototype model has a much greater explanation power. According to Lakoff (1987), not only categories of concepts have prototypical properties but also linguistic categories can be described in this way. This author suggests that language categories have the same structure as categories of concepts.

The prototypical view on category structure solves also many problems with the internal structure of categories. It explains blurred borders of categories as well as the intuitive property that not all members represent the category equally well. The prototype model allows for the categorization of marginal cases, which is hard to describe within classical theory. For example, it makes no problem to categorize a one-legged chair as a CHAIR, while it would be extremely hard if not impossible to conceive a set of rules describing all possible chairs.

In semantics, the prototype theory allows for describing meanings in terms of “information density” (Geeraerts, 1986). This gives much more flexibility in defining sets of properties needed for such a description: the prototypical conception organizes categories such that they are clusters of concepts and nuances. Ac-

According to Wierzbicka (1985), one should, however, differentiate between significant properties and prototypical properties. The significant ones refer to “semantic primitives” and are those which guarantee that an object which possesses them is indeed a member of the category in question. The latter ones are typical for a category but not obligatory.

Problems of the Prototype Model

Unfortunately, the prototype model outlined so far is not *the* magical answer to all problems concerning categorization processes and category structure. It also suffers from several shortcomings.

Although the prototype model was created as a counterproposal for categorization based on necessary and jointly sufficient conditions it cannot completely get rid of this formalism. The vertical axis of categorization is based on class inclusion which in turn is based on the implication relation. The implication relation however needs the reference to necessary conditions. It means that although the return to necessary and jointly sufficient conditions is not compulsory, there must be at least a trail of *necessary conditions*: a set of features may not be equivalent to a characteristic of category but it implies that an object being a member of the category de facto has those features.

Osherson and Smith (1981) investigated the prototype category in terms of two criteria: the relationship between complex concepts and their conceptual constituents and the truth condi-

tions of thoughts corresponding to the simple inclusions. The authors evaluated those issues by means of Zadeh's theory of fuzzy-sets (Zadeh, 1965, 1975) which was also used by Rosch (1975b) to represent the prototype model formally. The final conclusion of their work was threefold: either a prototype theory cannot be represented with the fuzzy-set formalism, or the prototype theory should be negated completely – what is however not recommended because this theory captures many ideas about categorization – or prototype theory is not complete and applies only to limited aspects of concepts.

“[W]e can distinguish between a concept's *core* and its *identification procedure*; the core concerns with those aspects of concept that explicate its relation to other concepts, and to thoughts, while the identification procedure specifies the kind of information used to make rapid decisions about membership. (...) Given this distinction it is possible that some traditional theory of concepts correctly characterizes the core, whereas prototype theory characterizes an important identification procedure.” (Osherson and Smith, 1981, p. 57)

The above shows that not all kinds of categories are equally well described by prototype theory. The best ones are naturally those which served as a base for this theory: perceptual categories, natural categories, artifacts etc. The most problems are connected with compositional concepts.

The problems with “standard” prototype theory can be solved in two ways. Either by application of prototype theory to the prototype itself or by redefining the mechanisms underlying the categorization.

The notion of prototypicality as characterized by Geeraerts is founded by four properties:

1. Prototypical categories cannot be defined by means of a single set of criterial (necessary and sufficient) attributes. (...)
2. Prototypical categories exhibit a family resemblance structure, or more generally, their semantic structure takes the form of a radial set of clustered and overlapping meanings. (...)
3. Prototypical categories exhibit degrees of category membership; not every member is equally representative for a category. (...)
4. Prototypical categories are blurred at the edges.(...)

(Geeraerts, 1988, pp. 343–344)

Following this author one can notice that not all of the above properties apply to all cases of prototypical objects (cf. table 2.1). Different prototypes can represent different properties of prototypicality and this means that a prototype is indeed autoprototypical. In fact, this characteristic of prototype leads to the next version of theory of prototype, the theory of family resemblances.

	<i>bird</i>	<i>vers</i> ¹	<i>red</i>	<i>odd number</i>
analytic polysemy coupled with intuitive univocality	+	-	-	-
clustering of overlapping senses	+	+	-	-
degrees of representativity	+	+	+	+
fuzzy boundaries	-	+	+	-

Table 2.1: Different prototypical objects (adapted from Geeraerts, 1988) characterized by four properties of prototypes.

2.2.2 Family Resemblance

The revision of the “standard” prototype model of categorization leads to a theory using an idea of *family resemblance* in order to describe categories. Wittgenstein (1971) argued that concepts or objects in the world do not have to have common characteristics in order to be understood as elements of one category. They can connect to each other only by resemblance. This “new” prototype theory, according to Lakoff (1987), is characterized by the two following principles:

- a) there is no longer a prototype as an entity representing a category, there exist only *prototypical effects*,

¹*vers* is a Dutch adjective, “which corresponds roughly to with English *fresh* (except for the fact that the Dutch word does not carry the meaning «cool»)”. (Geeraerts, 1988, p. 349)

- b) the relation between members of the same category is a *family resemblance* relation.

This idea is in some sense reversed in comparison to the former prototype model. The prototypical effects in a category are now only a consequence of the relationship between its members.

This change in the categorization principle leads at first to the change in category structure from radial one (cf. figure 2.4 for a category BIRD) to the more distributed structure where indeed a prototypical kernel exists, but where also outlying exemplars occur which not necessarily have any properties common with those forming the prototype (figure 2.5).

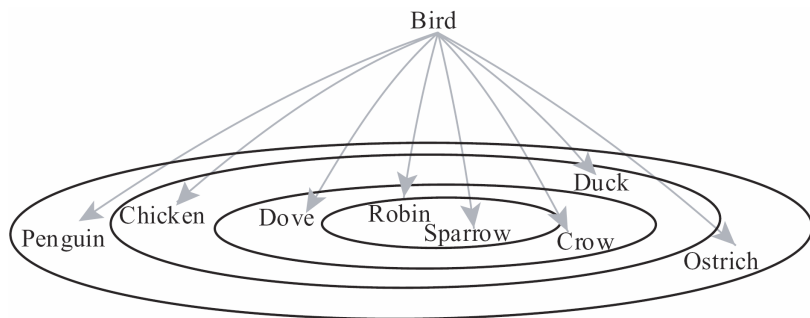

Figure 2.4: The radial structure of category.

This new category structure is based on family resemblance (Wittgenstein, 1971). In the “standard” version of prototype theory the notion of family resemblance was also introduced but (as suggested by Kleiber, 2003) it was used improperly and motivated by its false identification with similarity to the prototype.

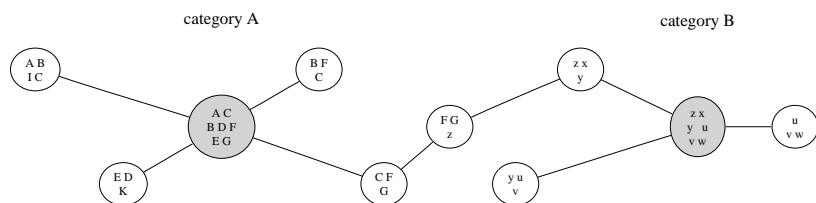

Figure 2.5: The non-radial structure of category. The grayed nodes play role of prototypical centers.

What is *family resemblance*? It is a similarity between at least two exemplars, while at the same time it is not necessary that any of similar properties is common for all category members. There also is no reference to the prototypical object and of course no similarity to it is required. In Wittgenstein's example of the game category it is even not possible to extract any kind of prototype, no game can be considered better representing this category than all others. This apprehension of categorization leads to a much more powerful mechanism: retaining all positive characteristics of the "standard" model, the family resemblance denies simultaneously the necessity of having similarities with some imaginary objects constituting the category center. As a spectacular example let us consider the categories BAYI, BALAN, BALAM and BALA of Dyirbal, an aboriginal language of Australia (cf. Dixon, 1982; Lakoff, 1986). These categories contain the following items:

Bayi : men, kangaroos, possums, bats, most snakes, most fishes, some birds, most insects, the moon, storms, rainbows, boomerangs, some spears, etc.

Balan : women, anything connected with water or fire, bandicoots, dogs, platypus, echidnae, some snakes, some fishes, most birds, fireflies, scorpions, crickets, the stars, shields, some spears, some trees, etc.

Balam : all edible fruit and the plants that bear them, tubers, ferns, honey, cigarettes, wine, cake.

Bala : parts of the body, meat, bees, wind, yam sticks, some spears, most trees, grass, mud, stones, noises, language, etc.

Clearly there is no single object which could serve as a center for each of these categories. However all of the elements are connected to each other by having at least one overlapping property. For example the moon in BAYI category is related to men, because in myths it is personified as a husband. Analogously, the sun is in the same category as women, because in myths it is incarnated as a wife.

Actually, the term prototype should be replaced with the term *prototypical effect*. Fillmore (1982), Lakoff (1987) and Geeraerts (1988) suggest many types of prototypical effects dependent on the type of category in question. That is why a prototype becomes only a surface effect and cannot be used directly to build up a category structure.

2.2.3 Exemplar-Based Model

The exemplar model of categorization was first mentioned in works of Brooks (1978) and Medin and Schaffer (1978). The main idea here is that a category is represented in people's mind with memories of all exemplars encountered in daily life. The consequence of this view is that there is no abstraction of category representation unlike in classical, prototype or family resemblance models.

The exemplar model's hypothesis utilizes a parallel search mechanism among all stored memories in order to categorize an unknown exemplar. Depending on the actual version of the model, either a category is chosen which exemplars are on average most similar to the categorized item, or the one which has the highest number of similar exemplars.

It seems that the exemplar model has an advantage over prototypical models in assigning objects to poorly defined categories or those which have too few exemplars to generalize. This advantage stems from the representation which is simply a set of unprocessed members of different categories. This representation however has also drawbacks.

Firstly, although there is no clear evidence on people's memory capacity it seems unlikely that everyone remembers all the incoming information ever and forever. Thus the performance of categorization should decrease with time, when exemplars are simply forgotten. However, there is evidence that exemplars influence categorization even if they are not remembered explicitly.

Barsalou (1992, pp. 27–28) mentions even more serious flaws in the exemplar-based model. People are clearly able to abstract from exemplars and to create general representations for categories. The exemplar model – by definition – can explain neither forming of those abstractions nor their use.

2.3 No Clear-Cut Between Models

Experimental data known so far shows clearly that the classical feature-based model of categorization is not sufficient. But it cannot be completely rejected. Even in the most sophisticated prototype-based models the comparison process is built in.

The prototype models of categorization “simply” compare an object to be categorized with some set of prototypes or other members of a category. The problem is how this comparison is being done. Rosch’s experiment (1976) concerning objects’ shapes may suggest that the comparison is a kind of pattern matching: an object is said to be a member of a given category when it is most similar to the pattern of a prototype for this category. But as Harnad (2003) points out

“it is simply not the case that everything is a member of every category, to different degrees. It is not true ontologically that a bird is a fish (or a table) to a certain degree; nor is it true functionally that sensory shadows of birds can be sorted on the basis of their degree of similarity to prototype birds, fish or tables.”

The same problem occurs with the family resemblance mechanism. It says that members of categories are similar to each other to some degree. Again, the question is how to measure this similarity if not on the feature basis? Similarly, the exemplar-based model suffers from this dilemma.

Kleiber (2003) points out that the prototype model actually describes categories also in terms of features (or properties). The feature mechanism is thus inherent within these more “psychologically justified” models. Thus a prototype can be defined as the set of the most common features within a category and similarity can be measured by the number of features and the degree to which they match the prototype. Similarly family resemblance could be defined by measuring the number of common properties and the degree to which they overlap.

2.4 Learning Categories

The prototype, family resemblance and exemplar-based theories describe phenomena related to categorization and category structure. However, none of those mechanisms explains how the category structure is obtained. Indeed comparing either to prototype, to other category members or using the set of rules requires that the category structure is already present. Thus, no matter what mechanism we assume to be appropriate for describing a category structure, a learning method has to be also defined.

Ashby and Maddox (2005) enumerates four main methods most commonly used for investigating category learning by humans.

Rule-based. Rule-based category learning is generally a method by which a subject learns the rules. These rules describe the strategy of categorization verbally. Several conditions must be met in this case: each stimulus must have a semantic label, the subject must be able to isolate each property of stimulus, and the rule combining information from different stimuli must be verbalizable (usually in terms of logical operations).

Information integration. In this learning method categorization is possible only if information from several sources is integrated on the pre-decision stage.

Prototype distortion. Learning randomly distorted single category prototype is a base for the prototype distortion method. There are two popular variations: (A, B) and (A, not A). In the former, exemplars from category A are presented against exemplars from the contrasting category B. In the latter method there is only one category presented in contrast to exemplars not attributed to any category.

Weather prediction. This last method has the goal of finding out whether a membership in category is deterministic or probabilistic. In deterministic learning each stimulus has un-

ambiguously assigned a member of a given category, whereas in probabilistic tasks at least some of the stimuli are randomly associated to more different categories.

Although it is not clear which of the above methods describes category learning by humans (if any) there are different phenomena connected with category acquisition. One of them is asymmetric category learning (cf. Quinn et al., 1993) which is investigated in the following chapters.

In the current chapter the models of categorization provided by literature have been outlined. These models constitute a basis for judging the categorization model I propose in this paper. This model is a connectionist one. Thus, the following chapter presents those aspects of connectionism which are needed to define the model.

CHAPTER 3

Connectionism

Connectionism is nowadays one of the theories of information processing within cognitive sciences (Medler, 1998). The term “connectionism” itself originates from the idea of representing a system as a net built of nodes and connections, where the main information is stored in connections. The categorization model described in this work deals with creating a taxonomy of concepts, formed as a network of interconnected nodes. Thus, from the architectural point of view, the model presented can and should be regarded as a variant of a connectionist system. Moreover, the data processing within this model involves passing a signal from one node to the others which is a common procedure in connectionist models

known as activation spreading. The task of this chapter is to show what connectionism is and how it is related to the categorization model.

Connectionism is regarded as the main alternative to a symbolic processing in cognitive sciences, especially in psycholinguistics. Figure 3.1 presents the hierarchy of main types of cognitive models currently developed. According to this classification, connectionist models belong to the class of quantitative, algorithmic ones. Further, they subdivide into two branches: localist models and parallel distributed processing ones. Actually, the localist models are also based on parallel distributed processing, but the difference (as will be explained later) is in the data representation used.

The current chapter is divided as follows. The Section 3.1 presents briefly the history of connectionist modeling. The following Section 3.2 explains the place of connectionist models within the model theory. Section 3.3 deals with data representation used in different flavors of connectionist models. The next two Sections, 3.4 and 3.5, describe in more detail distributed and localist types of connectionism respectively. Semantic networks, which are structures slightly similar to the connectionist networks, are highlighted in Section 3.6. Then, the opposition between brain structure and connectionist models is described in Section 3.7. Possible approaches to language processing in the connectionist context are discussed briefly in Section 3.8. Finally Section 3.9

explains how the model of categorization presented in this work can be defined as a connectionist model.

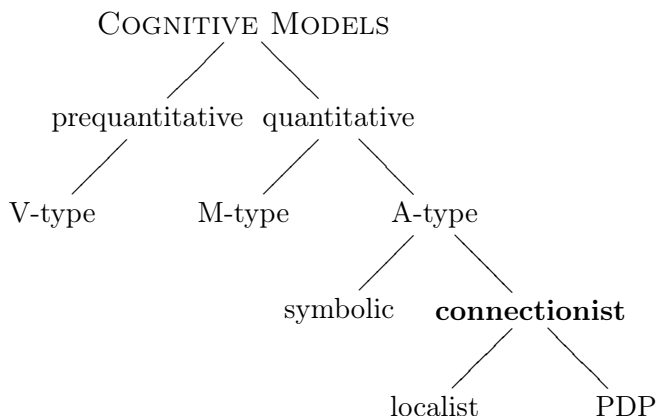

Figure 3.1: Hierarchy of different cognitive models (after Grainger and Jacobs, 1998). The leaf and branch names have the following meanings. V-type: verbal and boxological, M-type: mathematical, A-type: algorithmic, computational.

3.1 On the History of Connectionism

Network models come to light in 1940's when McCulloch and Pitts (1943) proved that networks of simple interconnected binary units, when supplemented by indefinitely large memory, were computationally equivalent to a Turing's universal computing machine (Turing, 1937). For these kinds of machines, Turing proves:

“It is possible to invent a single machine which can be used to compute any computable sequence.” (Turing,

1937, p. 241)

In the late fifties, Rosenblatt (1958) introduced perceptrons (see figure 3.2) as an improved version of the units in networks by McCulloch and Pitts. The innovation in Rosenblatt's work was the introduction of modifiable connection weights, which enabled networks of such units to be trained. Later, Rosenblatt (1962) invented the learning procedure for perceptron and developed the "Perceptron Convergence Theorem". This theorem asserts the convergence of a simple supervised learning algorithm for simplified neuron models.

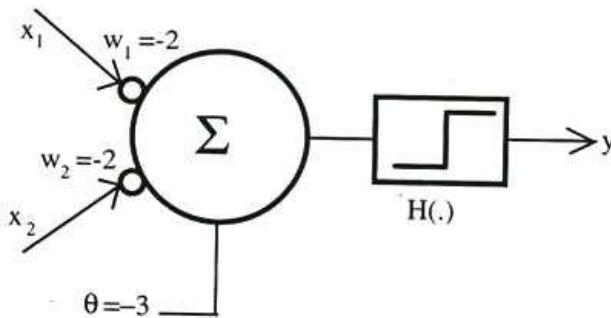

Figure 3.2: Rosenblatt's perceptron capable to perform logical not-and (NAND) function.

However, Minsky and Papert (1969) presented a number of fundamental problems which hold for these kinds of network architectures. For example, there are certain tasks which Rosenblatt's perceptrons could not solve. The most fatal was their inability to calculate parity which led to practical limitations in perceptron's

application. For example, a perceptron could not learn to evaluate the logical function of exclusive-or (XOR) and other linearly inseparable problems. Minsky and Papert suggested the possibility of developing perceptrons into more sophisticated architecture consisting of more processing layers. They predicted, however, that this architecture would suffer from similar inabilities as the single perceptron.

Another reason for suppressing the connectionist ideas of computation was the success of other approaches to so-called “artificial intelligence”. Among them were systems like STUDENT (Bobrow, 1969), Analogy Program (Evans, 1969), and a semantic memory program called the Teachable Language Comprehender (Quillian, 1969), which seemed not to suffer from limitations of connectionist systems.

In the seventies, not many significant studies on connectionism were done. Some important exceptions were the works of Anderson (1972), Kohonen (1972), and Grossberg (1976). Minsky and Papert’s prediction about the limitations of multi-layered architectures based on a perceptron idea, however, were not confirmed.

In the eighties the renaissance of network architectures began. The connectionism then split formally into localist connectionism (McClelland and Rumelhart, 1981; Dell, 1986; McClelland and Elman, 1986) and parallel distributed processing (Rumelhart et al., 1986b). The network modeling gained more and more attention

also because of dissatisfaction with the results obtained with the artificial intelligence models (cf. Graubard, 1988).

The “modern connectionism” which started in 1980s brought computationally powerful and trainable networks — new tools for investigating human cognition. The development of training procedures for multi-layer networks gave not only a tool computationally powerful enough to model problems of cognition but also a learning procedure to deal with those problems. Nowadays, connectionism is still evolving. The different network architectures and learning rules developed so far allow one to choose an appropriate tool for a specific problem.

3.2 Algorithmic Model Theory

Model theory in general is a branch of logic. In a broader sense, model theory is the study of the interpretation of any language, formal or natural, by means of set-theoretic structures, with Alfred Tarski’s truth definition (Tarski, 1933) as a paradigm. In this broader sense, model theory meets philosophy at several points, for example in the semantics of natural languages.

Algorithmic model theory (the theory of *A-type* models, cf. figure 3.1) investigates the application of model theoretic methods to different problem domains in computational science (cf. Otto, 2002). The most interesting domain from this work’s point of view is the domain of knowledge representation and artificial intelligence. Because descriptive logics are also being used as formal

languages for knowledge representation, it is relatively straightforward to connect it with model theory.

Connectionist models form a sub-branch of the more general class of algorithmic models. The power of *A – type* models is that they can be applied as tools to analyze the functioning of cognitive systems and processes. They, however, do not claim to provide the true solutions. Instead they can provide an explanation of how the system *could work* but not necessarily how it *does* work. The *A – type* models, and thus the connectionist models, have the potential to bring insights into the functionality of cognitive systems.

In the following an overview of the two main branches of connectionism, distributed connectionism and localist connectionism, is given.

3.3 Remarks on Data Representation

To start talking formally about the connectionism, one needs at first to consider data to be processed by the system. The form of data being processed by the connectionist system is the central factor that decides what properties a system should have in order to properly model a given phenomenon. The two main types of data representation are local and distributed (figure 3.3).

Between these two poles there exists a number of mixed representations. In the following localist and distributed representations are shortly characterized. The description assumes that the

input	local	distributed
a	■□□□□	□■□■□
b	□□□■□	■□■□□
c	□□■□□	■□□■□

Figure 3.3: Schematic illustration of the difference between local and distributed data representation.

data is represented in a system using a pool of units which can be characterized by a real number (the activation value).

3.3.1 Localist Data Representation

The localist representation originates from the work of Gall and Spurzheim (1809/1967) who claimed that particular knowledge is stored in specific regions of brain. In the meantime there are many flavors of localist representation. Those that can be presented in the clearest way as the basic representations of this type are strictly local and local ones.

- *“Strictly Local*
The item (...) is represented by appropriately configuring a single dedicated unit. The state of the other units is irrelevant.
- *Local*
The limiting case of a sparse distributed representation is one in which only a single unit in the pool is active. These representations are of-

ten also referred to as “local” (...). The key difference with strictly local representations is that here it matters what state the other units in the pool are in, viz., they must not be active.”

(van Gelder, 1999, p. 188)

3.3.2 Distributed Data Representation

On the other end of the representation spectrum there is distributed representation. This representation assumes that specific information is represented by more than just one unit. In addition, each single unit contributes to many representations. In other words, it is usually the case that the same subset of units can code many different pieces of information by means of different activation patterns. It means that no single unit holds enough clues to decode the information stored in the system’s pool of data representing items.

3.3.3 Meaning of a Unit

Another aspect of local versus distributed data representation opposition refers to the meaning and the interpretation of a single item used to store data. The simplest way to deal with it is to say that in localist systems each unit carries its own independent piece of information which can be interpreted without taking the state of other system’s parts into account. Even if the overall in-

formation is composed of multiple units, each one is independent.¹ Thorpe (1995) formulates this characteristic in the following way:

“With a local representation, activity in individual units can be interpreted directly. [W]ith distributed coding individual units cannot be interpreted without knowing the state of other units in the network.”

On the other hand, the distributed data representation makes clear that the meaning of a single, separated unit is useless. Only the overall state of the whole system carries meaningful information. This representation has its advantages (for example in case the system is partially damaged, because even then the data may be restored with some accuracy) but also disadvantages (e.g. very complicated ways to analyze the correlations between different pieces of data).

3.3.4 Semantic Problems

Talking about local and distributed representation always involves formal, semantic problems. The terms “*local*” and “*distributed*” are usually used in literature in many different ways and are in fact still not well defined as yet.

Page (2000) argues that the real localist systems can use only the strictly local representation. Moreover, what counts is not

¹This kind of representation where the meaning in macro-scale is composed of the state of many strictly local units is often referred to as representation by *microfeatures*.

the input and output signal form but the way it is processed. However many connectionist systems (eg. Dell, 1986; McClelland and Elman, 1986; Schade, 1999) are usually seen as localist ones, although they use not *strictly* local data representation for processing. This view can be justified by grouping representation units into layers and considering each layer as a different subsystem with its own, independent data representation. However, it still leaves the problem of localist and distributed representations vague.

In the following the short characteristics of sample systems using distributed or localist representation are given.

3.4 Distributed Connectionism

A distributed connectionist, sometimes referred to as artificial neural networks, is a computational method derived from observations about brain structure and properties of neurons. Such a network consists of a (usually) large number of simple processing units, called (*artificial*) *neurons* or just *nodes*. These nodes are interconnected by weighted links.

The main principles of connectionist models derived from general observations about the brain are as follows (according to McLeod et al., 1998):

1. An artificial neuron receives and sums up input signals.
Based on this sum the neuron's actual activation value is

calculated and passed during the next step as an actualized signal via weighted connections to other nodes.

2. The artificial neural networks are usually organized in layers and connections exist mainly between nodes in adjacent layers. There are in general no connections between nodes in the same layer or the connections have a different nature than inter-layer ones.
3. The influence of one neuron on another one depends on the strength of the connection between them (connection weight).
4. The weights' values are obtained during a learning process.

Due to the nature of input and output data (real-valued vectors) neural networks are often used to approximate real-valued functions. Because of this feature, neural networks may be called universal approximators, and they are exploited to estimate unknown (or very complicated) relationships.

3.4.1 The Artificial “Neuron”

An artificial neuron, often called a node, is a simple processing unit which is a further development of Rosenblatt's perceptron (cf. page 66). Its role is to calculate an activation value (according to some given function) out of the input data. The input data consists of signals from many other nodes, and the activation value

is used as the node's output signal during the next step. The schema of an artificial neuron is drawn in figure 3.4.

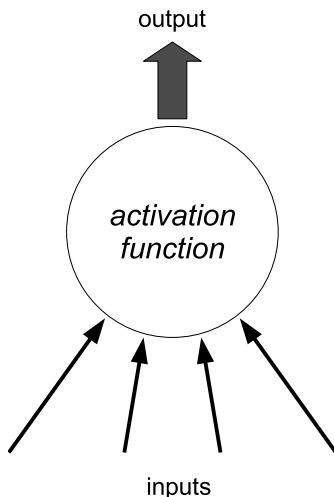

Figure 3.4: An artificial neuron.

In order to calculate the activation value, an activation function is used. Its concrete form is task-dependent. The standard and probably most often used activation function is derived from a logistic function (Kingsland, 1995):

$$P(t) = a \frac{1 + me^{-t/\tau}}{1 + ne^{-t/\tau}} \quad (3.1)$$

The special case of logistic function (3.1) used in parallel distributed modeling is called a “sigmoidal function” (equation 3.2) due to the sigmoid shape of its graph (see figure 3.5) or a “stan-

standard logistic function” (cf. for example McLeod et al., 1998; Ellis and Humphreys, 1999)

$$f(s_i) = \frac{1}{1 + e^{-s_i}} \quad (3.2)$$

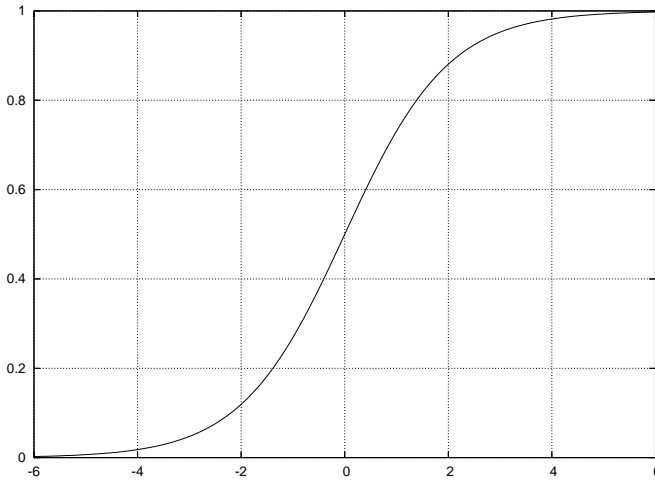

Figure 3.5: Sigmoidal (standard logistic) function.

In (3.2), s_i is the sum of the weighted outputs of those nodes which are connected to the node i , as given in equation 3.3

$$s_i = \sum_j w_{ji} a_j \quad (3.3)$$

In (3.3), w_{ji} denotes the weight of the connection from node j to node i and a_j is the activation value of node j .

3.4.2 Basic Architecture

There exists a large number of possible network architectures (i.e. ways how nodes are organized and connected). The most popular are so-called feed-forward networks in which a signal is propagated only in one direction: from the layer of input neurons through one or more hidden layers to the layer of output neurons. The name “hidden layer” means that that activation value patterns in those layers are not visible to the user.

In the following subsection the most basic network architecture is described as it is a starting point for many investigations involving distributed connectionist models.

Multi-Layer Perceptron (MLP)

A multi-layer perceptron is the most common neural network architecture. Two-layer perceptrons were first introduced by Rosenblatt (1958). The multi-layer version of perceptron has been proposed by Rumelhart et al. (1986b). Picture 3.6 shows the schema of the latter. The nodes are organized in three layers. One layer is the *input* layer (i.e. the activation of nodes in this layer, input nodes, depends directly on input data) and one layer is the *output* layer (i.e. this layer’s nodes’ activation pattern is considered to be the output of the network). The intermediate layer is called *hidden* because its activation distribution is not directly accessible for a user.

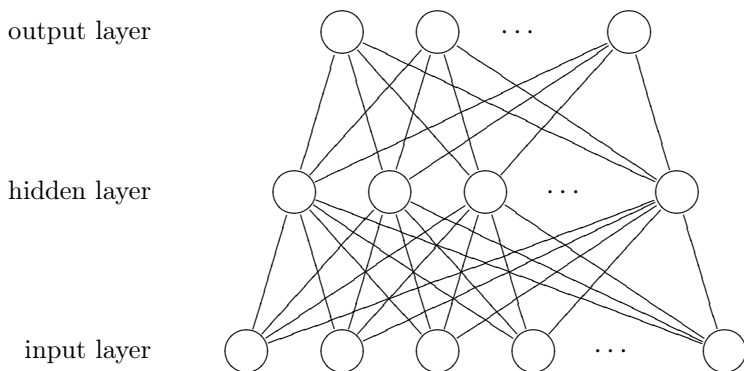

Figure 3.6: Multi-layer perceptron schema. Circles stand for nodes and lines for connections between them.

The multi-layer perceptron is a kind of *feed-forward* network, which means signals flow in only one direction: from input layer through hidden layers to output layer without any back loops.

3.4.3 Learning

In the case of artificial neural networks, learning is a process of changing connection weights. Usually feed-forward distributed networks are trained according to a supervised method of learning (cf. le Cun, 1985; Parker, 1985; Rumelhart et al., 1986a). The main attribute of supervised learning is that it needs a large number of input and output data pairs.

There exists a number of different supervised learning methods, rules and algorithms. For a multi-layer perceptron the most

common method is called *error back-propagation* (cf. Rumelhart et al., 1986a). The principle of this algorithm is the following.

1. The network is presented with input data selected (usually randomly) from the set of training data.
2. The output is calculated according to the activation function.
3. The output is compared with the desired result and out of this comparison the output layer error is calculated.
4. Based on the error found in step 3 and the current connection weights errors are calculated for the other network layers as well (“backpropagated”).
5. Based on the errors calculated in steps 3 and 4 and the existing connection weights, all the weights are modified.

The weights’ changes are usually controlled by two parameters:

- *learning rate*, which is simply a fraction of an error value taken into account when changing weights,
- *learning momentum*, which is a fraction of previous weight changes. The learning momentum is used to prevent the learning procedure being captured in a local minimum of the learned function.

Usually learning is applied until a given performance of the network is reached, that is, until the error rate decreases below some

acceptable level. In most applications, learning is done only once. After that the artificial neural network is used. After learning all weights remain fixed.

Until the back-propagation algorithm was presented, it was not possible to train perceptrons of more than two-layer. This algorithm definitely overcame the limitations of the first connectionist architectures which had been noted by Minsky and Papert (1969), and allowed for serious competition against the symbolic approach.

As the “extension” of multi-layer perceptron architecture there were two other network types proposed by Jordan (1986) and Elman (1990) in order to learn and process time sequences of input activation patterns. These networks contain one additional layer of units, called the “context layer”. The task of the context layer is to provide a short-term memory for a network. The difference between Jordan and Elman network types is that the former expresses context in terms of activation pattern of output nodes in the previous time-step of processing and the latter in terms of activation pattern of a hidden layer. The presence of short-term memory allows for processing sequences of input patterns, or, more precisely, for processing an input signal in context of previously processed ones. These architectures were the first ones which gave the possibility to train networks on sequences of arbitrary length, thus allowing for real language processing (for example, extracting grammar rules from sample sentences, cf. Lawrence et al., 2000).

The multi-layer perceptron and architectures derived from it have become a flagship for “modern connectionism” in its distributed version. They were successfully used also for categorization purposes (e.g. McClelland and Rumelhart, 1985; Kruschke, 1992; Dienes, 1992). The fatal disadvantage of distributed connectionist categorization models is that it is not possible in a simple way (cf. cluster analysis, Tryon, 1939) to retrieve the dependencies among learned categories, that is, the taxonomical structure. That is why, in my opinion, distributed connectionism alone is not the optimal solution for a categorization model.

3.4.4 Self-Organizing Maps

Another interesting artificial neural network architecture is a self-organizing map (SOM), originally proposed by Kohonen (1982). Those networks use so-called unsupervised learning (Hinton and Sejnowski, 1999) in which a model fits to observed data. In unsupervised learning, in contrast to supervised learning used in multi-layer perceptrons, the desired output is not defined.

The objective of SOM is to map the input data onto a multi-dimensional array. The most popular are, however, two- and three-dimensional maps. Each node in the network is characterized by an n -dimensional vector containing some data $W_{ij} = (w_1, \dots, w_n)$ and its physical location in the network. Like most connectionist systems, SOMs also operate in two modes:

1. *Training (learning) mode.*

In the training mode, the network organizes itself using competitive algorithms (e.g. winner-take-all). The organization is executed in the following way: the input data in form of a vector is presented, the node with the data vector which is most similar to the input one is chosen, and the vector is modified in a way to make it more similar to the input data. This process is repeated for all input data and usually in many cycles.

2. *Production (mapping) mode.*

In mapping mode, the input vector is compared to the vectors of all network nodes and the most similar one is chosen. The “winning” node can be physically localised and classified based on the location on the map.

Kohonen networks are often used for classification (or categorization) (Anderson and Mozer, 1989; Merkl, 1998), data compression (Amerijckx et al., 2003; Seiffert, 2005), pattern recognition (Carpenter and Grossberg, 1991; Ghosh and Pal, 1992) or to visualize large collections of data (e.g. WebSOM by Lagus et al., 1999, see figure 3.7).

The interesting (from the categorization point of view) property of self organizing maps is that they preserve the topology of input data. This means that similar input data are associated with the nodes in the network which have similar physical positions (cf. figure 3.7). This property makes SOM into a tool for

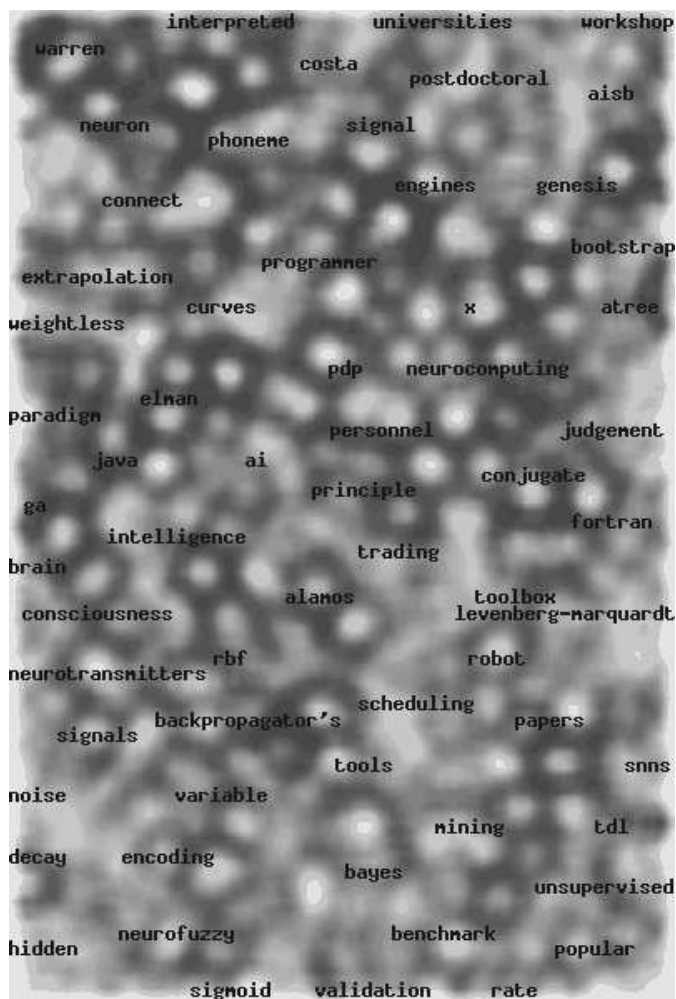

Figure 3.7: WebSOM example: the map of articles from usenet group `comp.ai.neural-nets`. The labels denote sample posts from the group. Similar articles are placed near each other on the map (topology preserving property). The color represents the density of documents: light areas contain more documents. (From: <http://websom.hut.fi/websom/>.)

cluster analysis (Jain et al., 1999) of input data, and allows for discovery of its hierarchical structure by creating a dendrogram.

A dendrogram shows the multidimensional distances between objects in a tree-like structure (figure 3.8). Objects which are closest to each other in the multidimensional data space form a cluster and are connected by a horizontal line. The distance of the particular pair of objects (or clusters) is reflected in the height of the horizontal line. Dendrograms are heavily dependent upon the measure used to calculate the distances between the objects.

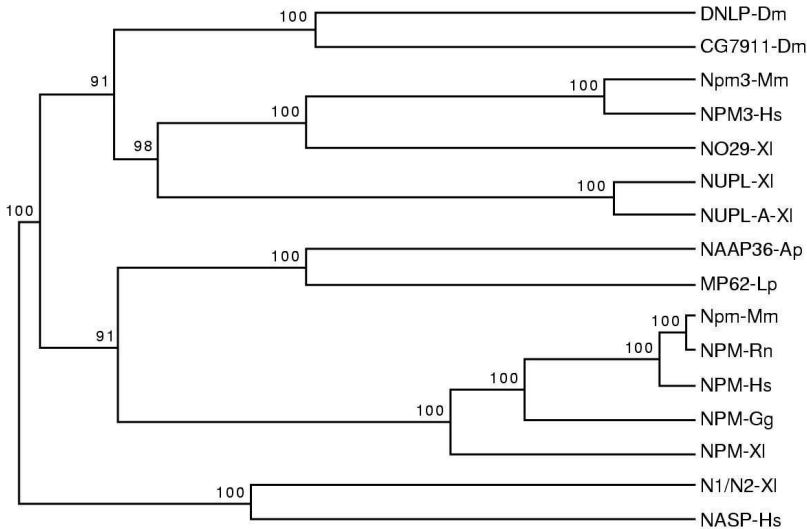

Figure 3.8: An example of a dendrogram

Modeling categorization processes with Kohonen networks suffers, however, from several limitations. First of all, the network is not able to generalize within a hierarchy of categorized items,

in the sense that unknown objects do not correspond to any node in the dendrogram. The only “generalization” possible is to judge which known object the input data is most similar to. Secondly, the limited number of nodes limits the capacity of networks, and thus number of categorized objects. Another drawback of this architecture is the catastrophic inference (forgetting), from which also many distributed connectionist architectures suffer (cf. French, 1999). This is why I judge that my model, presented later in this work, is better suited for modeling categorization processes as it makes a step toward overcoming these issues.

3.5 Localist Connectionism

In the following section, the localist view on connectionist modeling is presented.

“Localist connectionism is a branch of cognitive modeling characterized, as the name implies, by the use of localist representations. (...) Localist representations are simple processing units (as used by connectionist models) that can be usefully interpreted as standing for a single meaningful entity in the target world. These representations are contrasted with distributed representations, in which a single processing unit can be used to represent many different entities

and a single entity is represented by many different processing units.” (Grainger and Jacobs, 1998, p. 1)

It is very hard, if not impossible, to give general characteristics of connectionist models or to present a kind of flagship for this branch of connectionism. The reason is that localist models are task-driven ones, and almost always hand-wired for a specific purpose.

The most evident difference between localist and distributed connectionist systems, apart from the data representation used, can be seen in their applications. Traditionally the distributed systems are used to model learning processes while localist ones describe human performance (production processes). In the following, the idea of localist connectionist systems will be illustrated with several works on lexical access and language production.

This is done so that the reader will be able to better judge and classify the model described in this paper since this model can also be labeled as a “localist connectionist model”.

3.5.1 Theory of Retrieval in Sentence Production

Based on the localist connectionist mechanisms, Dell (1986) presented a spreading-activation model of retrieval in sentence production. His model postulated

“(...) a network of linguistic rules and units in which decisions about what unit or rule to choose are

based on the activation levels of the nodes representing those rules or units.” (Dell, 1986, p. 283)

The network used was organized in layers motivated by assumption that linguistic knowledge can be organized into separate levels, for example semantic, syntactic and phonological ones.

For his model evaluation purposes, Dell presented a demonstration of basic phonological errors production, namely slips of the tongue. The model tried to explain the causes of speech errors in the context that speaking is a production process and thus must be able to produce also novel combinations of sounds. This flexibility demand, however, makes the whole system prone to error.

3.5.2 Spreading Activation and Language Production

Starting from Dell’s ideas, another localist connectionist production model has been proposed by Berg (1988).

To be more precise, Berg’s work presents a localist architecture, consisting of memory units which simultaneously play the role of processing units. He considers the speech production process in the context of a parallel activation spreading mechanism in hierarchical networks.

Berg also validates his model by applying it to the simulation of speech errors. These errors are claimed to be caused by interactions on different speech production levels. The levels correspond to the mentioned hierarchical architecture of the network.

Again, the model is evaluated as an explanation of speech production errors. This evaluation shows that language production can be explained as a parallel interactive process within the system of linguistic units organized in networks.

3.5.3 Aphasia Model

To complement his work, Dell et al. (1997) developed an aphasia model. Again, the model is a network which consists of three layers: semantic features, words and phonemes.

In this model, lexical access is realized by activation spreading to the words layer. The most important feature of this model is that the retrieval process has two steps: lemma selection and phonologic encoding. The division of the retrieval process in language production has a long tradition. It has been proposed for example by Fromkin (1971) and Garrett (1975) and tested out by Kempen and Huijbers (1983). However, in Dell's approach there exists interaction between the layers on all steps of processing. In contrast to the classical approach by Fromkin and Garret (cf. also Levelt, 1989; Levelt et al., 1999), Dell's model thus preserves two stages of production but does not make them totally independent.

The model was used to explain the error patterns of aphasic and non-aphasic speakers in picture naming experiments. Its predictions successfully modeled the results from naming experiments conducted on human subjects.

3.5.4 Connectionist Speech Production

In his work, Schade (1992, 1999) presents a cognitive model for language production grounded in the localist connectionist tradition described above.

From the architectural point of view, this model offers two novelties: lateral inhibition and chains of control nodes. The latter assist in the sequential data processing in the network. Lateral inhibition, on the other hand, has multiple functionality. It not only protects the system from uncontrolled rise of overall activation (“overheating”) but also aids selection of proper node by increasing the contrast in activation values (see also Berg and Schade, 1992).

The most prominent result of the model presented by Schade was the ability to simulate several particular aspects of language production like slips of the tongue and aphasic behavior in one model.

3.6 Semantic Networks

At first glance, semantic networks look like localist connectionist models. However, semantic networks involve relations among concepts. In order to explain this difference, the current section discusses semantic networks in detail. Additionally, this section provides insight into the concept of “concept”.

3.6.1 Concepts

Concepts can be defined as

“[t]he elements from which propositional thought is constructed, thus providing a means of understanding the world (...)” (Hampton, 1999, p. 176)

Concepts allow for classification of objects and experiences and for relating them to the prior knowledge. Concepts exist in the human mind and are used to construct the model of the world. One of the important properties of concept to note is that they are “ad hoc”, that is created for specific purposes and, usually, if generalized beyond these purposes, they conflict with other concepts (Sowa, 1984).

Concepts can be regarded in reference to the meaning of a given word. They are then analogous to the word’s intension, that is to the set of all *possible* objects the word could describe. (In opposition to the intension, there is an extension, which denotes all *existing* objects actually described by the word in question.) In this sense concepts can be defined by properties or criteria without any concern for the existence of things that have those properties.

The relation between objects (referents), words (symbols) and concepts was illustrated by Ogden and Richards (1923) as “the meaning triangle” (figure 3.9). The meaning should be regarded from the following points of view:

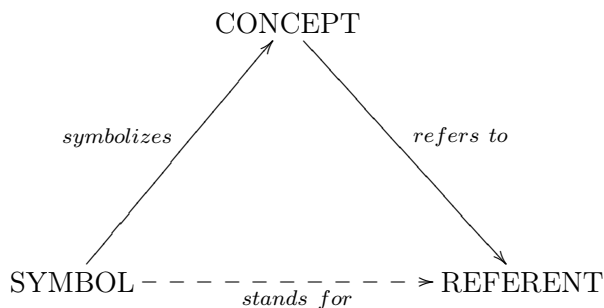

Figure 3.9: The meaning triangle.

linguistic – relation between word and concept: how the concept is expressed in language,

psychological – relation between concept and referent: what happens in human consciousness,

logical – relation between word and referent: how a symbol refers to the reality.

It follows that although symbols cannot completely capture the essence of a concept or of a referent, there is a correspondence between them. Either a word or an object can inspire the creation of a concept, and people may express their concepts with words or by identifying objects in the world.

The following section describes how a concept can be interpreted in relation to other ones. It also deals with the history of semantic networks.

3.6.2 Semantic Network

The meaning of a concept can be defined by relation to other concepts, or — in other words — by its position in the network of logical relations among them (White, 1975). This collection of relationships that concepts have to each-other as well as to percepts, procedures, and to motor mechanisms is called a semantic network.

From the technical point of view,

“[a] *semantic network* is a graphic notation for representing knowledge in patterns of interconnected nodes and arcs (edges).” (Sowa, 1992)

There are many types of semantic networks used to code quite different aspects of relationship among world elements. One of the basic relationships is called “*ISA*”. It describes the subtype relation among different types of those world objects. Because the “*ISA*” relation has the features of definition it forms the basis of a *definitional network*.

Definitional networks emphasize the *subtype* or *ISA* relation between a concept type and a newly defined subtype. The resulting network, also called a generalization or subsumption hierarchy, supports the rule of inheritance for copying properties defined for a supertype to all of its subtypes. Since definitions are true by definition, the information in these networks is often assumed to be necessarily true.

Origins of Semantic Networks

The definitional network is probably the oldest type of semantic network. The first known one was described by Greek philosopher Porphyry in *“Isagoge”* (cf. Porphyry, 1994) — his introduction to Aristotle’s *“Categories”* (cf. Aristotle, 1928) — in the following way:

“Substance is in itself a genus, and under it there is body; under body, animated body; under animated body, animal; under animal, rational animal; under rational animal, the human being; and under the human being, Socrates, Plato, and all particular human beings. Of these, substance is so general that it can only be a genus, and the human being is so specific that it can only be a species; whereas body is a species of substance, and the genus of animated body. But animated body is also a species of body, and the genus of animal; and again animal is a species of animated body, and the genus of rational animal; and rational animal is a species of animal, and the genus of human being; and the human being is a species of rational animal, but it is not the genus of any sub-division of humanity, so it is only a species; and anything which is immediately predicated of the individual it governs will be only a species, and not a genus. So, just as substance is the most general genus, being the high-

est, with nothing else above it; so the human being is only a species, and the lowest, or (as we said) the most specific species, since it is a species under which there is no lower species or anything which can be divided into species, but only individuals (...)"

Porphyry's description was later illustrated by Petrus Hispanicus (ca. 1239/1947), who created a graph resembling modern representations of definitional semantic networks (see figure 3.10).

The definitional network belongs to the class of monotonic logic. It means that new information, when added, monotonically increases the number of provable theorems. Already stored information cannot be deleted or modified. The definitional network can also be classified as a learning network. This term denotes a graph which can be expanded or built up based on knowledge acquired in the form of examples.

"Although the basic methods of description logics are as old as Aristotle, they remain a vital part of many versions of semantic networks and other kinds of systems. Much of the ongoing research on description logics has been devoted to increasing their expressive power while remaining within an efficiently computable subset of logic (Brachman et al., 1990; Woods and Schmolze, 1992). Two recent description logics are DAML and OIL (Horrocks et al. 2001), which are intended for representing knowledge in the semantic

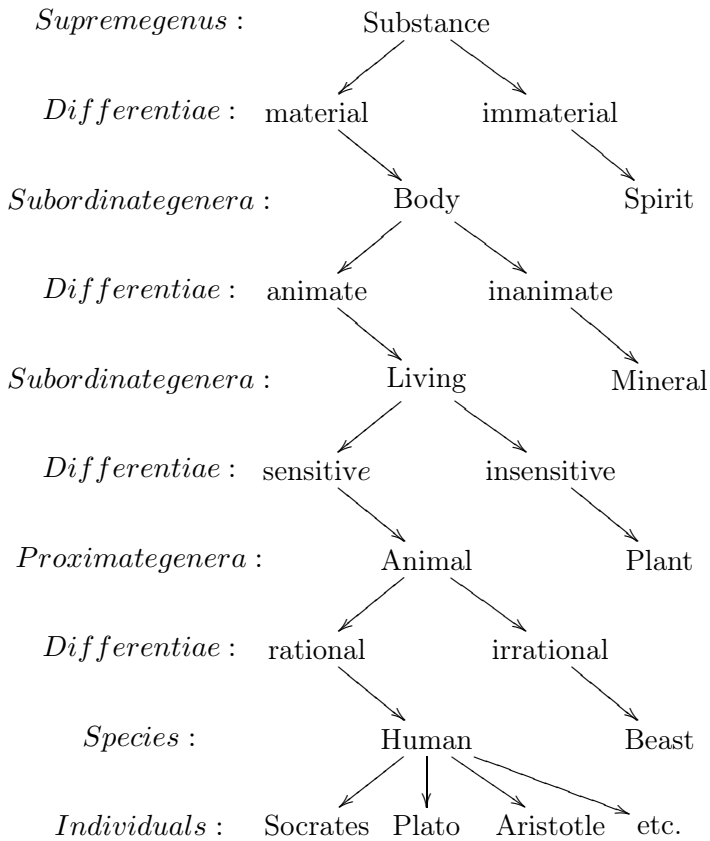

Figure 3.10: Tree of Porphyry.

web (Berners-Lee et al. 2001) a giant semantic network that spans the entire Internet.” (Sowa, 2002)

Apart from definitional networks, many other kinds of semantic networks exist, each expressing a different relation, like, for example:

- meronymy (A is part of B),
- holonymy (B has A as a part of itself),
- hypernymy (A is superordinate of B) — in some sense, a reversal of the definitional network,
- synonymy (A denotes the same as B),
- antonymy (A denotes the opposite of B).

It is also possible to introduce more than one relation in a single semantic network. In this case, edges become labels, which denote their meaning (figure 3.11).

The other types of semantic networks have, however, little relevance for this work, and thus will not be further described here.

Modern Applications

The definitional networks build a core for all common hierarchies used to define relations of concepts. The first applications of those networks were done in 1960s and used to define concept types and relations for machine translation systems (Ceccato, 1961; Masterman, 1962). The Masterman's network, in which concepts were

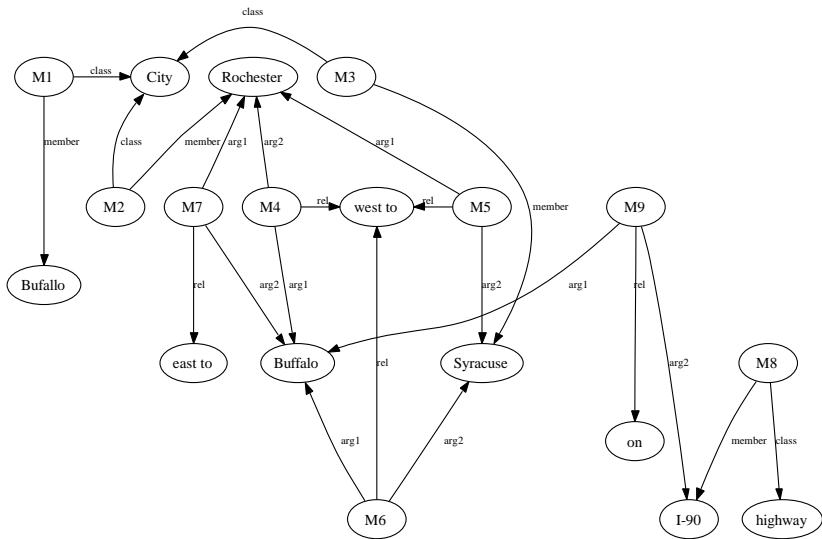

Figure 3.11: A sophisticated semantic network with many different relations among nodes.

organized into a lattice and inherited properties from multiple supertypes, was the first one to be called a *semantic network*.

Semantic networks were also widely used to build models of semantic memory. One of the first ones was proposed by Collins and Quillian (1969) in form of a hierarchical network (figure 3.12). The main relation between two concepts represented by network nodes was the ISA relation. Each concept was assigned a set of features which were inherited from higher level in the hierarchy.

Some years later, another model was suggested by Collins and Loftus (1975). In their model, Collins and Loftus proposed a network where the lengths of links represent degree of relatedness

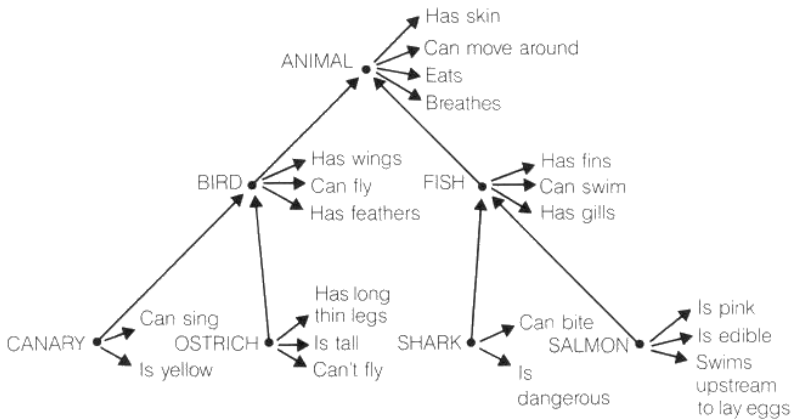

Figure 3.12: Hierarchical semantic memory model by Collins and Quillian (1969).

(figure 3.13). They also introduced the spreading activation process, in which the activation of one of the links lead to partial activation of connected nodes. To model the relatedness, the search time was dependent on link length and the degree of activation decreased with the distance.

Anderson (Anderson and Bower, 1973; Anderson, 1983) proposed a slightly different approach. Knowledge was still represented in networks, but connections were in the form of propositions, or statements of relations (propositional network models, figure 3.14). The model was capable of processing both declarative knowledge (represented in the model by propositional networks) and procedural knowledge (represented by production rules). Production was effected by interpreting of the propositional network.

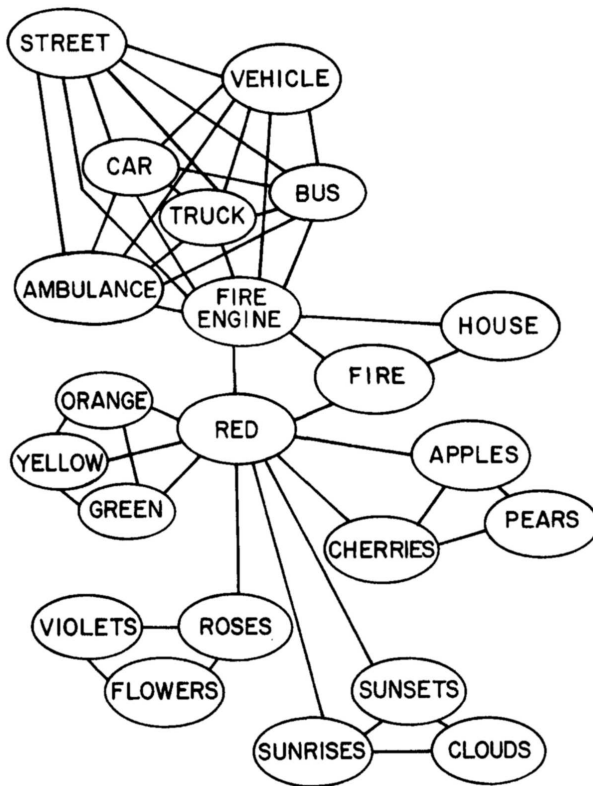

Figure 3.13: Spreading activation network in the tradition of Collins and Loftus (from Collins and Loftus, 1975, p. 412).

Modern semantic networks are based usually on a network developed by Woods (1975) and implemented by Brachman (1979) in a system called KL-ONE: Knowledge Language One. KL-ONE

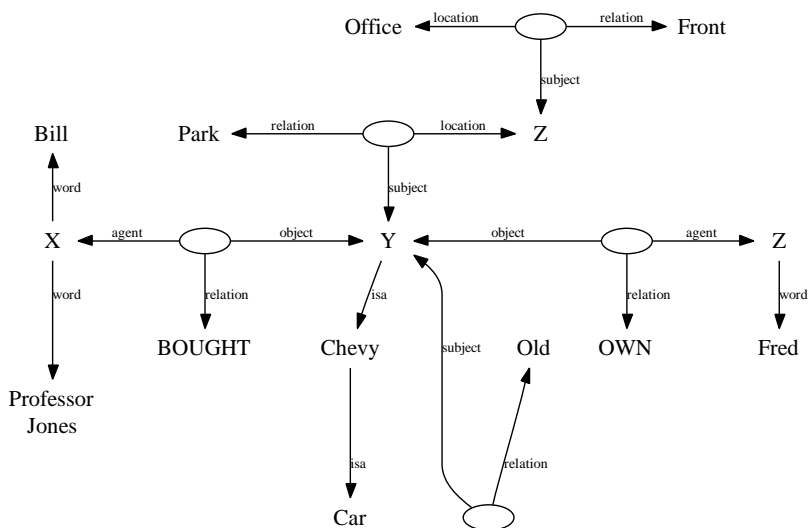

Figure 3.14: A propositional network representing a structure on the sentence level.

is a frame-language,² which has been developed from Frame Representation Language and Knowledge Representation Language. As an additional feature, in comparison to its ancestors, KL-ONE introduced constraints involving more than one slot.

“KL-ONE is intended to represent general conceptual information and is typically used in the construction of the knowledge base of a single reasoning entity. A KL-ONE knowledge base can be thought of as rep-

²Frame-language is a meta-language, where objects are represented by frames, which are collections of named slots that describe types of objects and relations to other objects. The frames are organized hierarchically.

representing the beliefs of the system using it. Thus KL-ONE fits squarely into the currently prevailing philosophy for building reasoning systems. (...)

In other words, KL-ONE provides a language for expressing an explicit set of beliefs for a rational agent.”
(Brachman and Schmolze, 1985, p. 174)

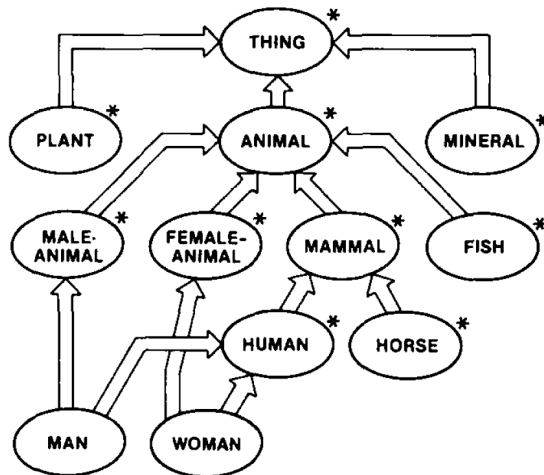

Figure 3.15: A simple KL-ONE network of generic concepts (from Brachman and Schmolze, 1985, p. 180).

KL-ONE can be used to represent a full range of semantical relationships, from simple objects hierarchy (figure 3.15) to elaborated semantical dependencies (figure 3.16).

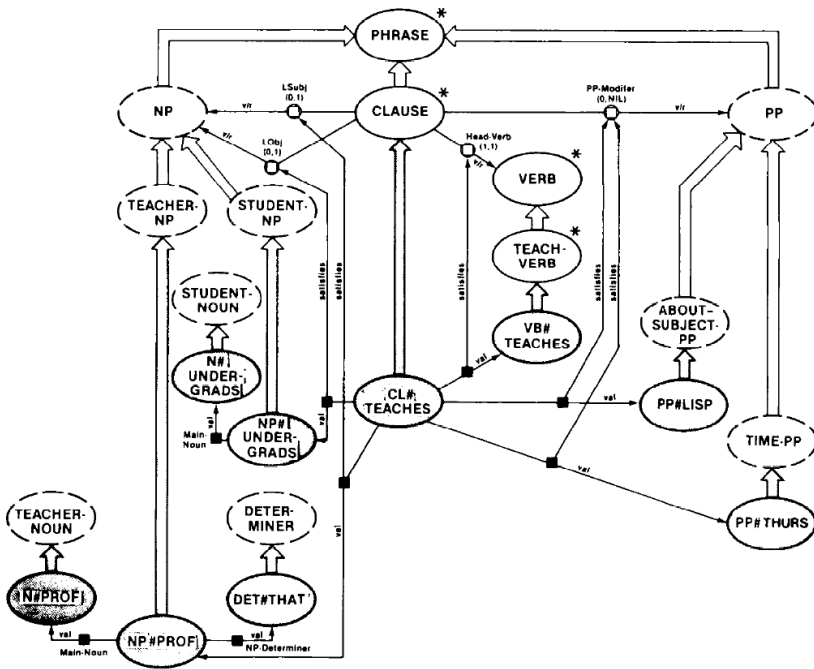

Figure 3.16: A network representing a sentence in KL-ONE (from Brachman and Schmolze, 1985, p. 214).

3.7 Connectionism vs. Brain Structure

It is often claimed that connectionist models (especially those of the PDP kind) are derived from the structure of brain. Indeed, in such models there are nodes and connections, where nodes are interpreted as a parallel to neurons. However, it should be noted that this is actually the only relation between connectionist models (artificial neural networks) and brains (real neural networks).

There are several reasons why connectionist models *are not*

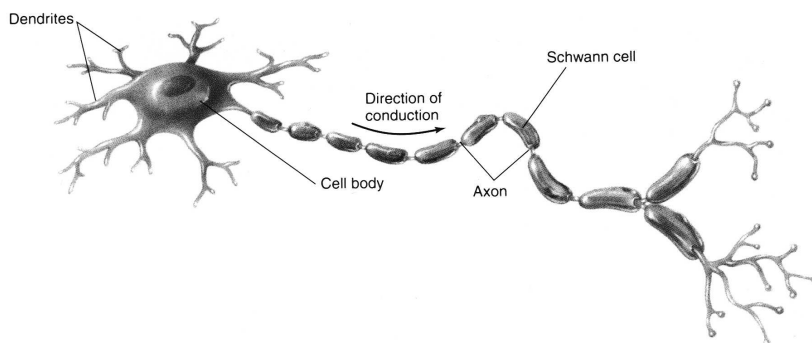

Figure 3.17: A neuron: the major structural and functional “unit” of nervous tissue.

analogues to the structure of the brain. First of all one has to note that nodes in connectionist networks are very simple processing units while real neurons (figure 3.17), on the contrary, are able to perform relatively complicated calculations on input signals (c.f. Koch et al., 1982, 1983; Mel, 1994).

An even more important reason to reject connectionist models as models of the human brain is just the the underlying concept of these models. They are only some kind of mathematical paradigm, some formulation of algorithmic procedures. Parallel distributed processing models are often called *universal approximators*, which means that they are just mathematical tools able to approximate (almost) any arbitrary kind of relation between two sets of numbers. Localist models are usually used to approximate even more abstract cognitive processes. There is no, or very little, attention paid to simulating how the brain really deals with the tasks in

question. Connectionism just a tries to model the task itself. The above is mentioned by Krebs (2005) as a clash between top-down psychological models and bottom-up neural environments. Thus

“(. . .) when simple ANNs [artificial neural networks] with small numbers of nodes are employed to model complex high level cognitive functions, the experimenter should evaluate whether the simplicity of the network can provide a *plausible* implementation, because it is all too easy to provide a neurologically *possible* model.” (Krebs, 2005, p. 1189)

3.8 Connectionism and Language Processing

The most widely spread approach to natural language processing and understanding is based on sets of rules and representations. The connectionist paradigm contrasts with this approach in that it is based upon sets of nodes and connections, which are described with vectors and matrices as well as complex apparatus to transfer information between nodes (like spreading activation mechanism).

There are two different strategies which represent linguistic phenomena within connectionist theory: *model-centered* and *principle-centered*.

“[M]odel-centered strategy proceeds as follows (. . .): specific data illustrating some interesting linguistic phenomena are identified; certain general connectionist

principles are hypothesized to account for these data; a concrete instantiation of these principles in a particular connectionist network – the model – is selected; computer simulation is used to test the adequacy of the model in accounting for the data; and, if the network employs learning, the network configuration resulting from learning is analyzed to discern the nature of the account that has been learned. (...)

The second, principle-centered, strategy approaches language by directly deploying general connectionist principles, without the intervention of a particular network model. Selected connectionist principles are used to directly derive a novel and general linguistic formalism, and this formalism is then used directly for the analysis of particular linguistic phenomena.”

(Smolensky, 1999, p. 188)

The strategy used in this work is the model-centered one: the model is created and evaluated.

3.9 My Categorization Model and Connectionism

The aim of my model is to create a *taxonomy* of concepts. It seems natural that this taxonomy is presented in a form of a graph (or tree) constructed from nodes, which denote concepts themselves, and arcs, which denote relations within pairs of concepts.

This kind of graph can be classified as a subtype of semantic networks, namely a definitional network. A taxonomy is nothing else than a definition of ISA relations (cf. definitional networks, page 92) between classes of objects (concepts) and their subclasses. It is obvious that an instance of a given class automatically is an (ISA) instance of its superclass. This simple definitional network is however enriched with nodes denoting features of concepts to be classified as well as with interrelations among those nodes and concepts themselves.

In order to provide more than a purely representational power, activation spreading and weighted connections are introduced. These properties make the model presented a part of the class of “traditional” connectionist systems. Labeled nodes make it rather a localist connectionist model. However (as will be shown further), my model, while showing strong localist characteristics, remains a mixed one.

To summarize: the model presented here is a connectionist model, displaying several properties of both distributed and localist approaches to connectionism. It contributes to the class of connectionist systems able to learn as well as those which perform. At the same time my model can be seen as a means for building a “living” taxonomy, a kind of a semantic network.

In the next chapter, the connectionist system able to create hierarchy of concepts is presented and evaluated.

Part II

Practice

Architecture and Operation of the Model

The description of the model's operation as well as its internal architecture are presented in this chapter. The system presented falls into the class of connectionist models (chapter 3, page 63). Since the model is connectionist, its main constituent is a network. The basic elements of this network are nodes. The structure of nodes is inspired by biological findings concerning signal processing in brain. (It must be noted, however, that the purpose of the system is not to model the architecture or functionality of the brain itself, but the higher cognitive ability: the categorization process.) Consequently, the signal flow in a network constructed from those structured nodes must undergo a proce-

ture that fits this architecture: this is the activation spreading mechanism, which takes care of transferring information within a network in general and within this model in particular.

4.1 A Node

In “traditional” connectionist systems (e.g. McClelland and Rumelhart, 1981), a node is a simple unit capable of performing basic operations on incoming signals. The state of such a node is defined by a given mathematical function, called an activation function, where the number of arguments is defined by the number of incoming connections. Several classes of activation functions are in use, among them: sigmoidal (logistic) functions (cf. McCullagh and Nelder, 1989; Jordan, 1995) for feed-forward networks in the PDP tradition; winner-take-all (cf. Schmutz and Banzhaf, 1992); different kinds of radial functions (cf. Broomhead and Lowe, 1988; Moody and Darken, 1989); self-organizing maps (Kohonen, 1982); and many other kinds dependent on the structure and functionality of the network. Nevertheless, the general characteristics of nodes in typical connectionist systems are that they do not have any sophisticated internal structure, and do not process incoming signals in a more elaborate manner.

In contrast to the above, the operation principle of each single node within my model is based on the finding that neurons are divided into subregions which are able to perform complex com-

putations on incoming signals (c.f. Koch et al., 1982, 1983; Mel, 1994).

“When two neighboring regions of a dendritic tree experience simultaneous conductance changes — induced by synaptic inputs — the resulting postsynaptic potential at the soma is usually not the sum of the potentials generated by each synapse alone. (...) [I]t has been customary to assume linear summation of excitatory and inhibitory inputs on the dendrites and to regard the thresholds associated with spike generation at the axon hillock as performing the elementary logical operations in the nervous system. It is, however, possible that synapses situated close to each other on the dendrite of a cell may interact in a highly nonlinear way.” (Koch et al., 1983, p. 2799)

“One of the questions of greatest interest in the study of neuronal information processing regards the limit of the computational power of the single neuron. In this vein, the (...) idea we consider here is that nonlinear membrane mechanisms, if appropriately deployed in a dendritic tree, can allow single neuron to act as a powerful multilayer computational network.”

(Mel, 1994, p. 1065)

While a single real neuron can be seen as analogous to the whole “classical” distributed connectionist network, it is justified

to assume that the real neuron can perform virtually any operation on the input signal, whether linear or not. This assumption underlies the working principle for a node used in the presented network. Such a node has a complex internal structure (rather than just performing simple addition, multiplication or integration) which allows for processing the input signal differently with respect to its source. In the presented network, a node processes the signals coming from its parent nodes in a different way than the signals received from its child nodes. This feature is crucial for both learning and performance activities. The general internal structure of a node is sketched in the figure 4.1.

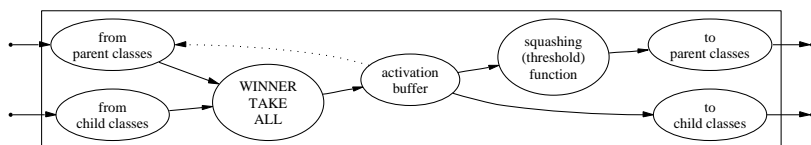

Figure 4.1: Internal structure of a node.

In the center of a node resides an activation buffer, responsible for storing the activation gained in the previous step of activation spreading. Moreover, each node has four “processing units” which calculate the activation components for each node’s input and output respectively. Those calculations are governed by several mathematical formulae and algorithms which are described in the following section.

4.2 Activation Spreading

The term *activation* is used here as an abbreviation for a node's activation value. It describes a state of a node. The activation is also a means for transferring information along connections from one node to another. Its current value is, roughly speaking, a function of its previous activation and of the state of the remaining network. It behaves, however, locally: only the nearest neighborhood influences the node in question. The more remote parts of the network affect it only indirectly.

The activation spreading mechanism is closely connected to the internal structure of the node. It also differentiates between signals coming from parent and child nodes as well as between outgoing signals.

There are four components which contribute to the activation value: input from parent nodes, input from child nodes, inhibition and the previous activation of the given node.

4.2.1 Signals from Parent Nodes.

Nodes' Phase Space and Attractors

The idea of the nodes' phase space is taken from physics.

phase space — (physics) an ideal space in which the coordinate dimensions represent the variables that are

required to describe a system or substance; “a multi-dimensional phase space”.¹

For a given node, each connection to a parent node is represented as an axis in a multidimensional space. In this space a node is placed in a point characterized by a combination of values of parent nodes’ activations for which the node in question should also be activated. Figure 4.2 provides a simple two dimensional example of two nodes in a phase space.

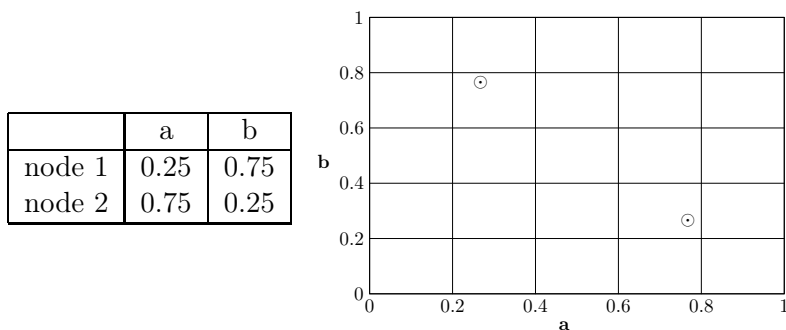

Figure 4.2: Two sample nodes in 2D phase space.

The phase space mechanism makes it easy to estimate how much the stimulus provided to the system differs from the one already coded as a node. Each node constitutes a center in a phase space relative to which the signals may be examined. The similarity between stimuli provided and those saved as points in phase space can be measured in terms of Euclidean distance.

¹From <http://www.thefreedictionary.com/>

The node's role in the network's phase space can be explained in terms of *attractors*.

“Let M be a smooth compact manifold, possibly with boundary, and let f be a continuous map from M into itself. The notation $f^n = f \circ \dots \circ f$ will stand for the n^{th} iterate of f . Recall that the *omega limit set* $\omega(x)$ of a point $x \in M$ is the collection of all accumulation points for the sequence $x, f(x), f^2(x), \dots$ of successive images of x . If we choose some metric for the topological space M , then $\omega(x)$ can also be described as the smallest closed set S such that the distance from $f^n(x)$ to the nearest point of S tends to zero as $n \rightarrow \infty$. The definition of omega limit set in the case of a continuous flow on M is completely analogous. Note that $\omega(x)$ is always closed and nonvacuous, with $f(\omega(x)) = \omega(x)$. Furthermore, $\omega(x)$ is always contained in the nonwandering set $\Omega(f)$.

Choose some measure μ on M which is equivalent to Lebesgue measure when restricted to any coordinate neighborhood. This can be constructed using a partition of unity, or using the volume form associated with a Riemannian metric. It doesn't really matter which particular measure we use, since we will usually only distinguish between sets of measure zero and sets of positive measure.

Definition. A closed subset $A \subset M$ will be called an *attractor* if it satisfies two conditions:

1. the *realm of attraction* $\rho(A)$ consisting of all points $x \in M$ for which $\omega(x) \subset A$, must have strictly positive measure; and
2. there is no strictly smaller closed set $A' \subset A$ so that $\rho(A')$ coincides with $\rho(A)$ up to a set of measure zero.

The first condition says that there is some positive possibility that a randomly chosen point will be attracted to A , and the second says that every part of A plays an essential role.” (Milnor, 1985, p. 179)

In other words, in dynamical systems, an attractor is a set of values to which the system evolves after a long enough time. For the set to be an attractor, trajectories that get close enough to the attractor must remain close even if slightly disturbed. The connectionist network presented here is a dynamical system because its state is time-dependent. The nodes (actually the set of weights of the input connections) play a role of attractors. When the system receives a set of input values they define a point in system’s phase space. This point’s coordinates change with the time and migrate in the direction of the nearest point defined by a already existing node. In this sense the network acts as an attractor network. In the case there is no attractor in the neighborhood

of the initial point, its location in phasespace remains virtually unchanged.

Overview

Signals coming from parent nodes are processed in a way similar to calculating a distance in the multi-dimensional phase space. The number of dimensions is defined by the number of incoming connections. Additionally, the weights of those connections set up a point in this space. The node is then able to calculate the Euclidean distance between the point representing the incoming signal (defined by activations of parent nodes connected to it) and the point set up by the weight values. Finally, an activation function is applied which calculates the activation coming from parent nodes based on current input signal and the node's previous activation (cf. the reciprocal dotted link which originates from activation buffer in the figure 4.1).

The resulting part of activation coming from parent nodes expresses the difference between the incoming signal and a signal to which a node is most sensitive, as well as a kind of history of previous input signals.

Mathematics

The multidimensional space is defined by incoming connections: their number sets the number of dimensions. Additionally, the weights of those connections set up a point in this phase space.

The node i calculates the Euclidean distance d_i between the point representing the incoming signal (defined by activations a_j of parent nodes connected to it) and the point set up by weight values w_{ji} of connections coming into node i . Then a Gaussian function of this distance is computed:

$$\widehat{in}_i^p(t+1) = e^{\frac{-d_i^2}{2r^2}} \quad (4.1)$$

$$d_i = \sqrt{\sum_j (w_{ji} - a_j(t))^2} \quad (4.2)$$

where w_{ji} denotes connection strength and a_j activation; r is constant and t represents discrete time. The parameter r in the Gaussian function controls how much the activation function is “blurred”: the smaller its value, the sharper the activation function (cf. figure 4.3).

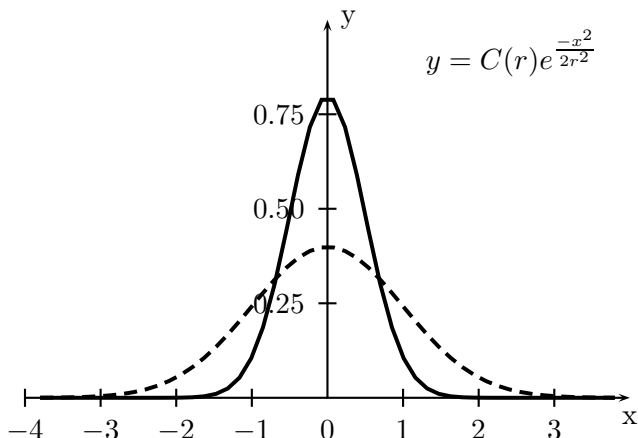

Figure 4.3: Example Gaussian functions: solid line with $r = 0.5$, dashed line with $r = 1.0$

Parameter r controls the network's sensitivity to the difference between data stored and new data which constitutes the current input. The higher the r value is, the less sensitive the network is to this difference. This parameter allows for modeling behaviors of different people, who react differently to the slight changes in stimuli.

Finally an activation function is applied which calculates the activation coming from parent nodes based on current input signal and the node's previous activation:

$$in_i^p(t+1) = \begin{cases} a_i(t)(1-\gamma) + \widehat{in}_i^p(t)(1-a_i(t)) & \text{for } \widehat{in}_i^p(t) \geq 0 \\ a_i(t)(1-\gamma) + \widehat{in}_i^p(t)a_i(t) & \text{for } \widehat{in}_i^p(t) < 0 \end{cases} \quad (4.3)$$

In this formula, γ is constant and describes activation decay in time. Naturally, the activation value should remain bounded in a range $0 \leq a_i \leq a_i^{max}$. In this case, $a_i^{max} = 1$ for all i . The activation function is chosen in such a way that the resulting part of activation coming from parent nodes indeed remains bounded in the desired range. If the final activation value in the previous step $a_i(t)$ is close to the range bounds, the change in the current step is smaller than for a final activation value lying in the middle of the range, due to the factors $1 - a_i(t)$ and $a_i(t)$ respectively, which weight the incoming activation $\widehat{in}_i^p(t)$. Moreover, if the activation value transgresses the bounds and falls out of the given range $0 \leq a_i \leq 1$, it will be pulled back into this range in the next

step.

4.2.2 Signals from Child Nodes

Signals from child nodes are calculated simply as the arithmetic mean of the child nodes' activations weighted by connection strengths.

$$in_i^c(t+1) = \frac{1}{N} \sum_j^N a_j(t) w_{ji} \quad (4.4)$$

The weights w_{ji} are connection strengths.

The motivation is as follows. Child nodes j denote subcategories or exemplars of categories defined by a given main node i . Thus, the most important information is how well, on average, the category is represented by the data currently processed by the network. For this purpose, the arithmetic mean is well suited as it gives the average activation for nodes j which represent the category in question.

4.2.3 Final Activation Function

The activation components coming from parent and child nodes are finally subject to a winner-take-all process. In addition, the inhibition is subtracted.

$$in_i(t) = \max(in_i^c(t), in_i^p(t)) - inh_i(t) \quad (4.5)$$

where (w_{ji}^{inh} is the strength of inhibitory connection):

$$inh_i(t+1) = \sum_i^N a_i(t)w_{ji}^{inh} \quad (4.6)$$

The task of inhibitory connections is twofold. On the one hand, they prevent so-called “overheating”, i.e. uncontrolled rise of activation values in the network’s nodes. On the other hand, and even more important for a categorization model, they enhance the contrast between nodes that do not belong to the same category. This enhanced difference among exclusive categories is one of the aspects of cognitive economy (cf. Rosch, 1988).

Further calculations differentiate between connections going in direction of feature nodes and of class nodes. For connections going to class nodes a squashing function is applied which keeps the final value in a range between 0.0 and 1.0. This method is another mechanism to prevent “overheating”. In the presented network the following function is applied:

$$a_i(t) = \begin{cases} 0 & \text{for } in_i(t) \leq 0 \\ in_i(t) & \text{for } in_i(t) \in (0, 1) \\ 1 & \text{for } in_i(t) \geq 1 \end{cases} \quad (4.7)$$

For connections going in the direction of feature nodes, a threshold function is used:

$$out_i^p(t) = \begin{cases} 0 & \text{for } in_i(t) \leq \theta \\ in_i(t) & \text{for } in_i(t) > \theta \end{cases} \quad (4.8)$$

where θ denotes a threshold value. The threshold function was designed because the feature nodes hold the description of currently processed object. To change or to adapt this description, the signal coming from class nodes must be strong enough, thus ensuring that the object was recognized or categorized well enough. If too low signal levels could influence the state of feature nodes, the characteristics of categorized objects would be too unstable to be processed correctly.

4.2.4 Implementation

The implementation of the spreading activation mechanism, which is a central part of the network algorithm is presented with more technical details in appendix A, page 223.

4.3 Connections

The connections between nodes are bidirectional and symmetric with respect to weights. However, they are treated asymmetrically with respect to activation flow: the activation from parent to child nodes flows without restrictions but not the other way round. A child node's activation influences a parent node's only in case it transgresses some given threshold. This is designed because child nodes have richer featural characteristics which makes them more sensitive to errors. That is why child nodes need to gain more activation before they are able to modify the activation of their superclasses. This mechanism corresponds to the fact that the

activation flow must be stable enough to change the activation pattern in higher layers of the network.

In the case that the incoming activation pattern for a child node is close enough to the one already learned by the network, the activation mechanism ensures that a given node reaches the threshold immediately and can also influence its parent nodes.

4.4 Learning

One of the unique features of this semi-localist architecture is its ability to learn. In principle, there is no sufficient definition for learning.

“The problem is that learning is such a vast topic; it affects almost everything we do – from learning to tie our shoelaces when we are young to studying chemistry at college or learning how to make friends.” (Lieberman, 1992, p. 32)

Very roughly it can be said that learning involves a change in an organism’s capacities or behavior brought about by experience. In the case of this connectionist system, learning simply means the ability to store additional data and to restructure the network in a way to reflect dependencies between known facts.

The presented network incorporates the *unsupervised* method of learning. In the unsupervised learning there is no predefined correct output state for the network. The networks has to adapt to

a combination of input patterns. There are two most important kinds of unsupervised learning methods: Hebbian learning and competitive learning. In the first method learning is determined by correlations in activation patterns (Hebb, 1949). In the former case, the central part of learning algorithm is a unit with the highest activation level (for example like in SOM's; Kohonen, 1982). In the presented model, the learning proceeds in a Hebbian-like style: connections are created and weights are adjusted without comparison to a set of target outputs but only on the base of analysis of correlations in activation patterns.

Three kinds of learning (cf. Sowa, 2002) are used.

Rote learning (storing data in the structure of network). This kind of learning is used to store input data in the network. It is comparable to long-term memory. Rote learning, in its principal form, is basically just memorization. It avoids going into details of presented data and acts without understanding the relationships involved in the data.

In principle, rote learning is connected with memorization by repetition. In this case, however, no repetition is involved and the data is memorized instantly after it is presented.

Connection weight changes. Changes in connection weights are a means to create the working structure of the network: the taxonomy itself. The changes in connection weights are the most common way of training any connectionist system. Especially in systems created in the PDP tradition (cf.

Rumelhart et al., 1986b), this is actually the only sensible way of learning because in these systems the whole knowledge is represented by sets of weights. In my connectionist model, unlike in PDP systems, the change of weights is only one of three learning methods: knowledge is stored not only in links and their strengths but also in nodes themselves.

Restructuring takes place also in the development of the taxonomy. It is done by creating nodes and connections as well as removing connections. The newly added nodes denote taxonomy classes and the links denote relations between each pair of classes. The restructuring can be seen as an aspect of constructivism:

“Constructivism models incorporate the principle of nonstationarity, a principle that in theory of automata refers to a system’s ability to make changes to its underlying mechanisms. (...) [T]he central component of the constructivist model is that it does not involve a search through *a priori* defined hypothesis space, and so is not an instance of model-based estimation, or parametric regression. Instead, the constructivist learner builds this hypothesis space as it learns, and so is characterized as a process of activity-dependent construction of the presentations that are to underlie mature skills.” (Quartz and Sejnowski, 1997)

Restructuring is the most powerful method of learning applied in the system in question. It allows for memorizing new data by adding nodes, for generalization from the memorized facts as well as for creating the taxonomical structure itself.

Despite the fact that the above-mentioned learning methods are different, they all have a common characteristic, one which is desirable for learning within connectionist models. Ellis and Humphreys (1999) define this characteristic as follows:

“An important feature of all the various learning procedures is that they depend only on local information, for instance the activations of the units at either end of the connection, rather than any global property of the network or distant parts of it.” (p. 654)

4.4.1 Concept Learning

Concepts as constituents of semantic networks were introduced in Section 3.6.1, page 90. In the following the application of this idea to the presented model is explained.

“Psychologists use the term *concept formation*, or concept learning, to refer to the development of the ability to respond to common features of categories of objects or events. *Concepts* are mental categories for objects, events, or ideas that have a common set of features. Concepts allow us to classify objects and

events. In learning a concept, you must focus on the relevant features and ignore those that are irrelevant.” (Pettijohn, 1998, p. 191)

In principle, the concept of “concepts” allows for grouping things according to their functionalities or common features, not to focus on the individual items. Thus, the concept formation is very close to the categorization or generalization task.

In machine learning jargon, the learning method leading to the formation of a network within the model presented here could be called “concept learning”.

“[A] concept is exemplified by a set of positive examples (cases that are examples of a concept) and a set of negative examples (cases that are not examples of the concept). In concept learning, the learner is attempting to construct a rule or algorithm that allows it to completely separate the positive and negative examples.” (Raynor, 1999, p. 59)

In the presented model, a positive example is embodied by features describing an instance of the class in question, while all instances of other classes together with their classification constitute the pool of negative examples. The creation of taxonomical structure as well as of inhibitory connections ensures the maximal separation of concepts (classes).

4.4.2 Introspective Processes

The introspection phenomenon may be defined as the direct observation of one's own mind and its processes. It was widely introduced to experimental psychology by Wundt (1874). In the original sense, Wundt used the term "introspection" („Selbstbeobachtung“) to define another source of empirical facts.

“We may add that, fortunately for the science, there are other [then psychological experiments] sources of objective psychological knowledge, which become accessible at the very point which the experimental method fails us. These are certain products of the common mental life, in which we may trace the operation of determinate psychical motives: chief among them are language, myth and custom.” (Wundt, 1904, p. 5)

“Thus psychology has, like natural science, two exact methods: the experimental method, serving for the analysis of simpler psychical processes, and the observation of general mental products, serving for the investigation of the higher psychical processes and developments.” (Wundt, 1897, p. 23-24)

The investigation of introspection was rejected as an implausible method for general mental processes investigation. However, there has not been enough serious criticism of introspectionism to cause its complete rejection (cf. Vermersch, 1999). The process of

introspection can be successfully used in some cases. In particular, reasoning itself may be described with this method.

Introspection involves only internal memories and assumptions. The introspective reasoning could thus be defined as processing of already known facts in order to extract relationships among them. This kind of reasoning thus takes into account only memories of the presented facts.

The presented connectionist system exploits a kind of an introspection process. At first, only raw facts are directly memorized without further processing (rote learning) and are stored in a kind of long-term memory. This action is however not introspective and serves only to prepare the domain in which future introspective processes take place.

The proper creation of taxonomy, which aims at extracting the structure of acquired data, is eventually done by an introspective process. By means of this process, the network creates a general structure of concepts and relations among them based on the internally stored knowledge. This process involves self-analysis of the activation flow through the network and incorporates restructuring the hierarchy by modifying connections and adding new nodes (cf. examples in sections 6.1.4, page 144 and 6.1.5, page 145). During the operation, the network does not refer any longer to the original input data or any other external resources. Network's connections and structure are modified according to already known facts only, resulting in the fully formed taxonomy.

The connectionist system, based on the mechanisms just presented has been built and tested against data coming from psychological experiments. The evaluation is described in the next chapter.

CHAPTER 5

Implementation

Each idea, in order to be used in practice, needs to be implemented. In the case of the connectionist system presented here, the implementation was realized as a computer program. This chapter describes the goals of the implementation as well some design details.

5.1 Objectives

The implementation of the connectionist system in question was not designed as a production system. Its goal was to provide a tool

to test the behaviour of the system. Thus, it was not optimized for performance.

The modularity of the network (which is a main component of the system presented) is reflected in the modularity of the computer program. There are several components defined:

- single nodes,
- connections (excitatory and inhibitory ones),
- the network, and
- tools to process input and output data as well as to produce the visualization of the network's current structure.

The network module makes use of node and connections modules and uses them as building blocks. The whole network also defines the information flow (spreading activation) which is common to all network setups. Testing a system creates further additional demands on the network, like working with different input data and delivering results in different forms and formats. These demands were satisfied by custom tools developed to process the respective data.

5.2 Realization

The Java programming language (in version 1.4.2) was used for implementation (Java Website, 2007). This choice was motivated by

the ease of development thanks to many useful mechanisms delivered with the programming language. Java is an object-oriented programming language and thus perfectly suited to implement modular systems. It is, however, suboptimal with respect to the calculation effectiveness, but this aspect was not of great importance (see above). Different modules of the system were developed as different Java classes, which is a common practice in object oriented programming languages.

Another tool used in the development setup was GraphViz by ATT (GraphViz Website, 2007) along with its *dot* language (Gansner et al., 2006), which simplified the graphical representation of the networks created.

5.2.1 Nodes

A node (represented by class `Node`) was designed as a simple container for node-specific data like label, activation and several internal variables used for calculating activation value (for example, an activation buffer). This simple design was motivated by the fact that this class is shared among several types of networks, which were tested during development. Thus, the actual calculation was transferred to the current network class, although logically it takes place inside of a node.

5.2.2 Network

The main component of the implemented system is a Java class, which represents the network as a whole. The set of nodes, representing the network was implemented as an array (Java standard class `ArrayList`) containing objects of a class `Node`. All connections were represented by two-dimensional arrays of real numbers (with a double precision: `double[][]`).

To simplify the development, the inheritance property of Java programming language was used. The basic features of the connectionist system were implemented in a single `Net` class. This class contains mainly the spreading activation mechanism, which doesn't change along with different usages of the network. Code snippets which realize the respective tasks, are presented in Appendix A (page 223) for illustration.

Each of the experiments described in chapter 6 has different demands with respect to the input data and the expected visualization of the output results. Thus, for each experiment a separate Java class was created, which inherited general functionality from the `Net` class, but realized the specific input and output behaviour.

5.2.3 Network visualization

To present the development of the network structure, the `GraphViz` tool (`GraphViz Website`, 2007) was used. This tool is able to draw graphs, which can be described in one of several different formal

languages. For the purpose of the network visualization the language *dot* (Gansner et al., 2006) was used.

In order to create a *dot*-compatible description of the network (for an example see Appendix B, page 227), a class `NetPrinter` was created. Its task was to analyze the structure of the data contained in the object implementing one of the `Net` subclasses and to create a text file with the corresponding *dot* description. Then the tool from GraphViz package was run automatically to produce a vector graphic image file in EPS (encapsulated post script) format. Such created images are used in this work as an illustration of network structure and operation.

In one experiment – the categorization of ellipses (section 6.1) – it was necessary to subclass the `NetPrinter` in order to adapt the shape of nodes on the output image. The overridden methods were placed in `EllipsePrinter` class.

5.3 Summary

The class diagram 5.1 shows the classes used along with the most important fields and methods. As mentioned before, the detailed calculations are performed by Java code, which is presented in the Appendix A.

The system was implemented with use of Borland JBuilder IDE¹ (JBuilder, 2007) version 9.0 Enterprise and tested on the

¹IDE — Integrated Development Environment

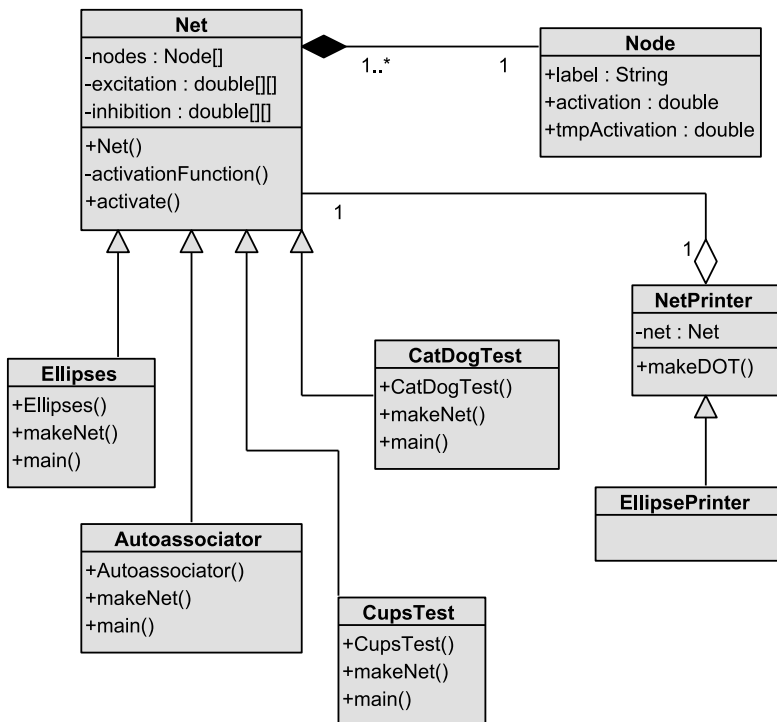

Figure 5.1: Class diagram. Only the most relevant fields and methods are shown.

Pentium 4 class computer with 2.0 GHz clock and 1 Gigabyte RAM memory under Windows XP operating system.

The implementation of the connectionist network as described in this chapter was used to perform a series of experiments in order to evaluate the system. Those experiments are explained and commented in the next chapter.

CHAPTER 6

Evaluation

This chapter presents the results of a series of simulations on the cognitive properties of the presented model of categorization. The simulations have been run to evaluate the model. Evaluation here means two different things. First, there is evaluation of the model as an IT-system. Second, there is evaluation of the model as a cognitive model. Both kind of evaluations are discussed in this chapter.

With respect to the evaluation of the model as IT-system, the simulations have to illustrate that the model can handle the tasks it has been designed for. The tasks in question are “creating a taxonomy” out of a set of item descriptions (section 6.1), “autoasso-

ciation” (section 6.2), and generalization (section 6.3). These sections concentrate on the proof-of-concept aspect of the IT-system evaluation. An example is given for every task, such that the reader gets a good idea how the model solves the tasks. In order to evaluate a system like the model at hand as an IT-system one has to run additional tests (Liggesmeyer, 2002; Schmitt, 2003), such as tests with broken input data. Although some of these kinds of tests had been performed to obtain the model run, they are not discussed here since they do not provide any further insights. The bottom line is the model is usable if it can perform the tasks mentioned successfully.

With respect to evaluating the model as a cognitive model, one has to check whether its task performance exhibits a behaviour that is in accordance with the behaviour that subjects exhibit in psychological experiments. In order to evaluate the model at hand as a cognitive one, two experiments have been run, one for fuzzy categorization (section 6.4) and one for asymmetric category formation (section 6.5). It is to be noted that fuzzy categorization has not been a property of the model from the functional (IT) view of it. Fuzzy categorization has not been implemented into the model. So, it is interesting how the model reacts under this question. The idea here is the following: the performance of the model is compared to the results of psychological experiments, namely those by Labov (1974). The question is whether the model passes this test in the sense of Popper’s 1935/1994 “Bewährung”

(Gadenne, 1998, cf.). The same holds for asymmetric category formation. Here, the behaviour is compared to an experiment by (Quinn, 2002). In this case, the model's behaviour can be attributed to the statistical distribution of features of stimuli that infants were exposed to. The experiment on asymmetric category formation therefore provides some support for explanation of the effect given by Mareschal et al. (2000) and offers additional insight how the effect can be explained in detail. In summary, with respect to evaluation as a cognitive model, the model is successful if its behaviour is similar to human behaviour as exhibited in psychological experiments, and if the model provides additional insights about the reasons behind the human behaviour.

6.1 Introductory Simulation: Creating a Taxonomy

This section describes step-by-step a general routine for creating a taxonomy with the use of the presented network and illustrates it through examples. Creating a taxonomy is the very first step which must be performed before any other properties of the network can be used. Since the network itself forms a taxonomy, it means also creating a structure of the network.

6.1.1 Training Data

The network operates on data which consists of sets of features weighted by real numbers. The weights express the degree to which the respective feature is present in the class's definition.

This is however *not* the degree of *importance* of the feature. For example, in the case of color, coded as a mix of red, green and blue components, the weights for the respective basic colors express only in what ratios they are mixed and not which one is more or less important.

The features can be chosen arbitrarily. The concrete set of used weights and values is task-dependent. The network's processing mechanism allows for use of both binary and real valued weights. The choice between those two types in the following presented experiments and examples is thus arbitrary, and made only to keep the examples as easy as possible to interpret.

Example. To investigate the process of creating a network a simple example with a single real valued feature will be used. The example illustrates the categorization of ellipses defined by a ratio of their semimajor axis to the semiminor axis. Table 6.1 presents the data used within the example. In the dataset there are two “horizontal” ellipses (i.e., with horizontal semiaxis longer than vertical one): ellipse_3 and ellipse_4; three ellipses very close in shape to a circle (ellipse_2, ellipse_5 and ellipse_6) and two “vertical” ones (i.e., with vertical semiaxis longer): ellipse_0 and ellipse_1.

6.1.2 Storing the Data

In the first step the presented data is memorized only (stored). This is done by rote learning (cf. section 4.4, page 123). Because

object	ratio
ellipse_0	2.0
ellipse_1	1.95
ellipse_2	1.15
ellipse_3	0.5
ellipse_4	0.55
ellipse_5	1.0
ellipse_6	0.95

Table 6.1: Data for introductory simulation.

of the local characteristics of the data representation used, the network must be expanded to store new knowledge. Thus, for each dataset, feature nodes are created as necessary. Additionally, class nodes are created denoting the respective set of all co-occurring features. Because the features are characterized not only by their presence but also by a degree of this presence (value), the features are said to co-occur only when their values equal within a given precision. Between class nodes and feature nodes excitatory connections are created with weights corresponding to the values of respective features.

The procedure described above constitutes one of the constructivist aspects of the model presented in the current work. When data is not already represented within the network's structure, the network is expanded to deal with the new knowledge.

6.1.3 Creating a Hierarchy

Based on the data stored in already created feature and class nodes a hierarchy is created. The hierarchy developed in this phase of learning reflects the relations among items only as far as this is provided explicitly by the input data. One can assume that in most cases the structure of the network created after this step is not the final hierarchy. For example, if only the data concerning exemplars for one category is presented to the system, the network's structure is very flat, usually having no more than two or three levels.

During the hierarchy build-up, the network undergoes the following procedure. For each pair of class nodes, both nodes are subsequently activated. The activation is spread to the feature nodes layer and the activation patterns are compared. If one of the nodes generates an activation pattern comprised in the other one's pattern, it is assumed to be its superclass. For example, let us assume the following sets of binary features:

Set 1. a, b, c, f, g

Set 2. b, c, d

Set 3. a, f, g

In the above example, **Set 1** describes a child node of a node characterized by **Set 3**, while **Set 2** does not have any direct relation to the other two.

This principle is based on the simple assumption that a subclass contains all features of its superclass and at least one more, a distinctive one. The comparison of patterns is performed with a given precision in order to gather classes characterized by features which values do not differ significantly. This precision is characterized by a threshold θ ; all values falling under θ are treated as equal.

Example. Figure 6.1 shows the results of storing the data and creating a hierarchy. The node ELLIPSE denotes just a node which is defined by a features *ratio* with some value. As previously mentioned, because the input data (cf. table 6.1) is not structured at all, the form of a network reflects no real taxonomical structure at this point. The network has a relatively flat structure of two levels only.

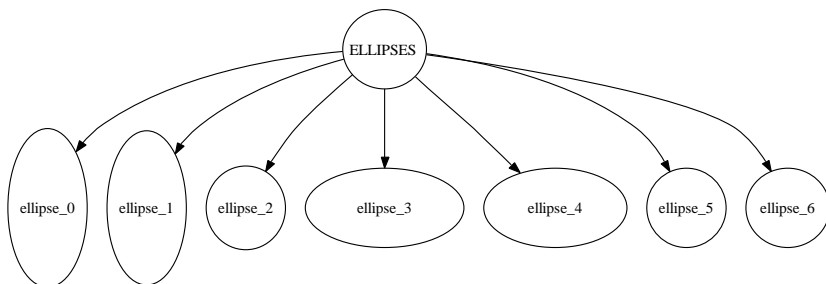

Figure 6.1: First step in creating a taxonomy: raw input data presented as a network structure.

6.1.4 Network Pruning

The previously described steps of creating a taxonomy lead to a network which usually contains superfluous excitatory connections that do not represent direct class – superclass relations. Because the hierarchy creation algorithm discovers only category inclusiveness relations, it is the case that all subcategories are linked to the main category even if there are other levels of specifications between them. For example, a pigeon would be linked to the node denoting animal category even if there also exists a node for a bird (cf. 6.2). Those connections are removed by an introspective process (cf. section 4.4.2, page 128). This process analyzes the acti-

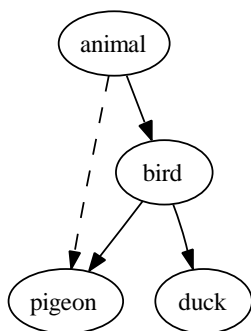

Figure 6.2: The illustration of the incorrect class—superclass connection. The dashed arrow denotes the undesired edge.

vation flow between two nodes and compares the activation values in all node pairs. The comparison drives the decision whether two nodes remain in direct class—superclass relation or not. Roughly speaking, nodes are assumed to lie on adjacent taxonomical levels when the activation in the subordinate node comes only from

the node representing a superclass. Subsequently, inhibitory connections are introduced to enhance differences between exemplars presented to the system.

Example. In the dataset used there is no structured data and thus no given hierarchy. This means that no superfluous connections are created as they exist only between non-adjacent levels in the taxonomy.

The figure 6.3 illustrates the algorithm of comparing the activation in order to detect class – superclass relation on another example. In the figure 6.3a) the activation is spread via direct connection from node animal to node pigeon, whereas in the figure 6.3b) the activation is spread via all available connections from node animal to node pigeon. The activation level is denoted by the darkness of a node (the higher activation value corresponds to the darker node filling). Because the direct connection delivered less activation than “normal” activation spreading, it is assumed that there are nodes on intermediate taxonomical levels. Thus, the direct animal—pigeon connection is superfluous and is removed: figure 6.3c).

For a real illustration of network pruning see section 6.1.6.

6.1.5 Discovery

So far the network constitutes the representation of raw facts known from input data only. This representation is structured as far as it is provided by this data. That means that relations

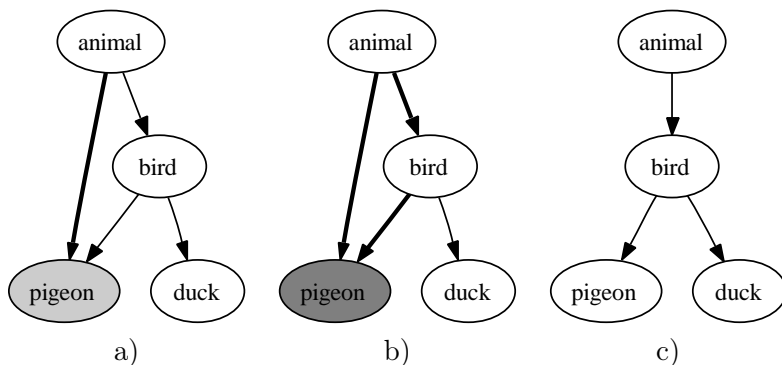

Figure 6.3: The detection of the incorrect class – superclass connection: a) activating using a direct connection only, b) activating using all direct and indirect connections, c) superfluous connection removed. (More explanation in text.)

between classes are known only if they result directly from the definitions.

However, this state does not guarantee the best taxonomy possible. Usually there exists more information that can be drawn from the underlying data. The discovery procedure is another introspective process (cf. section 4.4.2, page 128) which aims at improvement of the existing network. The process attempts to discover parts of the hierarchy which were not provided explicitly. This is achieved by analyzing pairs of exemplars. Therefore pairs of class nodes are analyzed again with respect to the featural patterns.

The process can be roughly defined as comparing how different features are present in descriptions of items provided by the input data. (Those descriptions are so far stored in the interconnected

net consisting of feature and class nodes.) If the features for two or more classes overlap (with respect to their presence and value) they form a description of another class which is assumed to be a superclass for those currently being analyzed. The description created thus is presented to the system as new input data.

The generalization process involves, in addition to creating new descriptions, also their integration into the existing network structure. To assure correct integration, the new descriptions are introduced in the exactly same way as the original data. Thus the problem of superfluous connections described in the previous section arises once more.

The discovery process is a crucial factor with respect to one of the most important networks characteristic: generalization. With respect to this property, it allows for categorization of objects sharing several features common to the objects stored in the network's structure during the learning phase.

Example. The network resulting from the discovery of the new nodes is shown in figure 6.4. Beside nodes already present in the taxonomy, three new ones are introduced. These new nodes correspond to the three discovered “classes” of ellipses presented: one with horizontal axis longer than the vertical axis, one with both axes almost equal in length and one with vertical axis longer than the horizontal one. The introduced links connect all nodes with respect to the class—superclass relation, not necessarily only those on the adjacent levels of hierarchy.

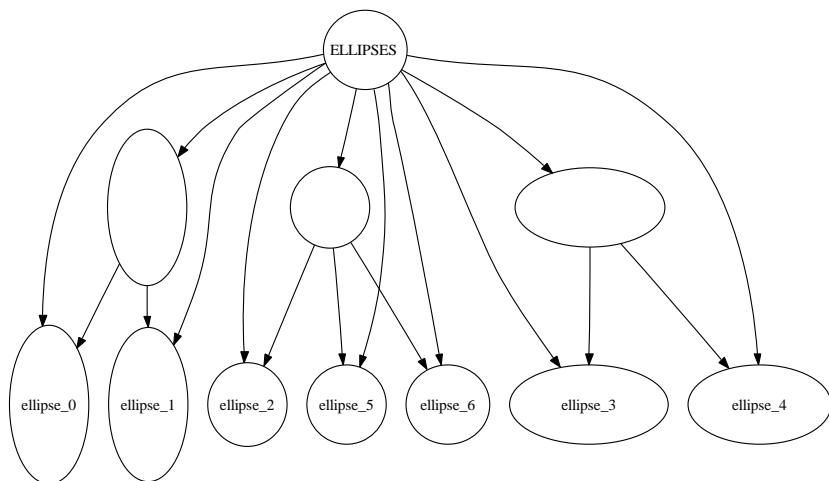

Figure 6.4: The form of a network after the discovery procedure.

6.1.6 Final Network

The network created so far contains nodes representing all terms which could have been discovered from the presented data. However, because the data discovered in the previous step was introduced in the same fashion as the original input data, the network suffers again from many superfluous connections. This is of course still undesired as it introduces unwanted chaos and destroys the clear taxonomical structure.

Therefore, the final step in the procedure of creating a taxonomy from examples is to clean the network by removing superfluous connections. This pruning is done according to the algorithm described in section 6.1.4 above.

The resulting connectionist system reflects the taxonomical

structure of the data as far as it was possible to discover based on the data delivered. Now the learning procedure is complete and the network can be used for “production” purposes.

Example. Figure 6.5 shows essentially the same network as figure 6.4, but superfluous connections have been removed. The remaining links correspond to the direct class—superclass relations only. Thus, a taxonomical network emerged.

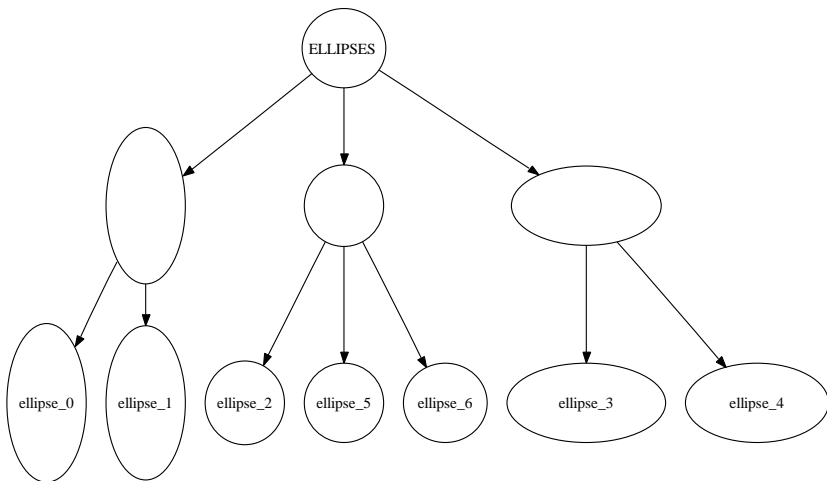

Figure 6.5: The final form of a network, which corresponds to the taxonomical structure.

6.1.7 Summary

Section 6.1 presents a quick overview over the creation of a localist network which structure reflects the taxonomy of the input data. The network is produced in two main steps:

- creating a raw network (which depicts only the raw data), and
- restructuring it (in order to create the full taxonomy that can be deduced from the presented data).

In the following, experiments and simulations using the finished network will be described in order to explore its properties and behavior.

6.2 Introductory Simulation: Autoassociation

The autoassociator in distributed connectionism is a relatively simple architecture in which the output signal is looped back to the inputs of network's nodes. In localist connectionism, however, the autoassociation property has received little research attention.

This section presents the autoassociation property of the network. Autoassociation is illustrated by an example of binary features in order to simplify the exemplification of this process.

6.2.1 Preparing a Network

To investigate the autoassociation property one first needs a complete network. Thus, a network is created according to the procedure described in the previous section.

Example. A network is built from the data presented in table 6.2. The data describes roughly several types of military equipment.

Objects are defined by several binary features describing their main characteristics. Of course, the dataset is very simplified in order not to lose the process overview in the jungle of unnecessary connections. The resulting taxonomy is presented in figure 6.6a.

object	features
LEOPARD_2	armour tracked selfprop tank
JAGUAR_1	armour tracked selfprop antitank hot
JAGUAR_2	armour tracked selfprop antitank tow
FH_70	towed howitzer
PzH2000	armour tracked selfprop howitzer

Table 6.2: Data for autoassociation simulation.

6.2.2 Autoassociation Process

The autoassociation property is a special case of pattern association and means that a network is able to recover its full state from partial description of the activation pattern. This feature of a network can be seen as a kind of long-term memory where sets of units are associated into patterns which can be recalled on demand.

The importance of the autoassociation property manifests itself in two main topics. One of them is object recognition under noisy conditions. This means that the network is able to classify items even if the feature set given as input data is blurred or corrupt, or several features are missing. This ability reinforces the system operation in environments where available data is distorted and thus enhances system's robustness.

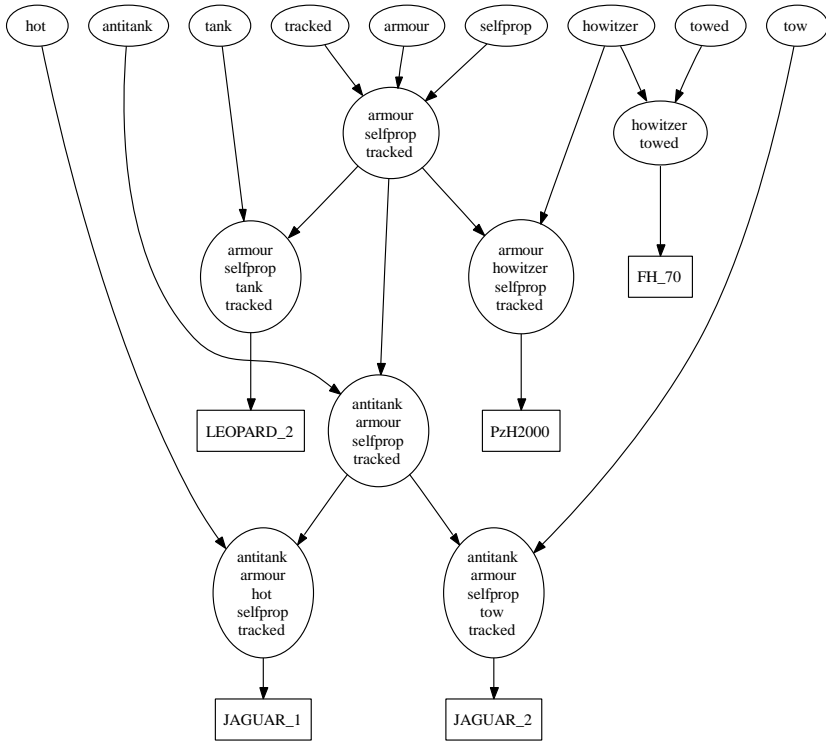

Figure 6.6a: Starting network for autoassociation demonstration.

In a more general sense, the autoassociation property means “noise reduction” and the ability to recognize and recall incomplete patterns. The property is equivalent to analogous properties in contemporary models of vision (Ge and Iwata, 2002; Rolls, 2003) and memory (Rolls and Treves, 1997).

Another application of the autoassociation property is its use in discovering novel items. In the case that system converges to a state far from the initial one, the input data can be treated as novel data (cf. section 6.5, page 169).

Example. The autoassociation procedure is evaluated in this case as a way to complete the description of an item. In the network representing data from table 6.2 two feature nodes are activated. To simplify demonstration, they are chosen to unambiguously define an item. Thus, the simulation starts with activation of two feature nodes (cf. figure 6.6b):

- TRACKED, which is common to most of objects described by the network and
- HOT, which is a distinctive feature of the JAGUAR_1 object.

Following thereon, the activation spreading mechanism is used to transfer the signal between network nodes. The activation pattern in the network changes, and the activation is being transferred into feature nodes such that the full characteristics of the JAGUAR_1 are reconstructed (figure 6.6c).

In this way the autoassociation property manifested itself by associating part of the description (two initially activated nodes) with the complete characteristics of the item in question.

6.3 Introductory Simulation: Generalization

The *generalization* term is used to indicate the property of the network which allows it to categorize objects previously not known. Along with autoassociation, the generalization property is seen as a strength of connectionist systems. However, it was thoroughly investigated for systems based on a distributed data representation (cf. Shekhar and Amin, 1992; Musavi et al., 1994; Christiansen and Chater, 1994) but again neglected in the case of localist architectures.

Generalization is especially important for understanding the phenomena of categorization. Roughly speaking, the most vital part of the categorization process can be seen as generalizing over many concrete objects or instances of a given class. Obviously, this is a common and important property of human categorization. People, for example, do not have any problem to categorize most birds they never saw before as instances of the class *bird*. Generally speaking, unknown objects can usually be assigned to some broader category.

In the model presented, ability to generalize is developed during the learning phase. Unlike in the distributed data representation architectures, the generalization property is not a result of

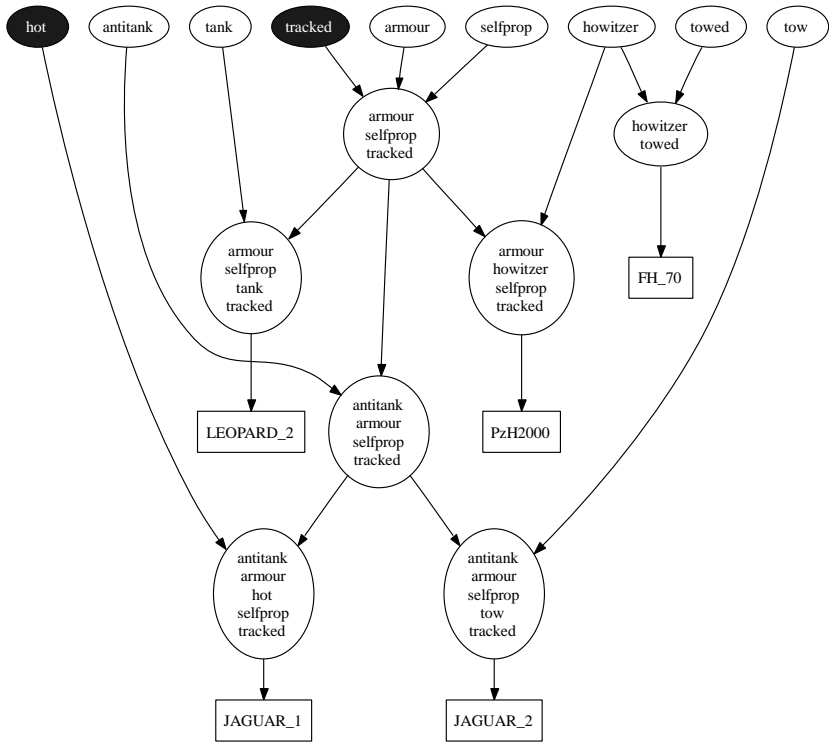

Figure 6.6b: First step of autoassociation: activating some nodes.

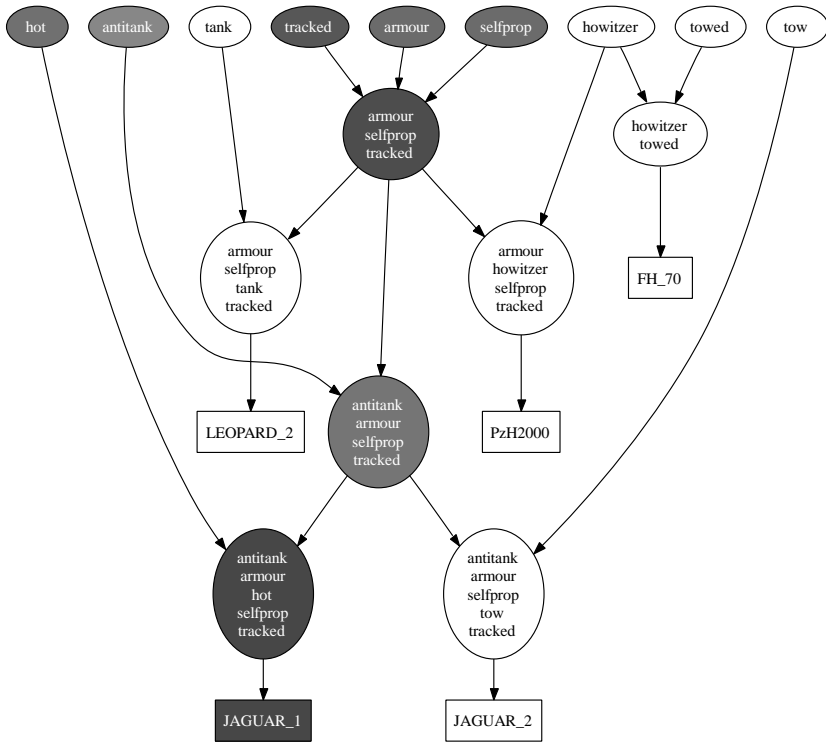

Figure 6.6c: Autoassociation successful: object characteristics are restored.

approximation done with numbers of free parameters (connection weights). It is a result of the restructuring of the network and the creation of additional nodes, which carry the characteristics common to two or more objects presented to the system. Thus the proposed solution seems to be more robust with respect to new data introduced (see comments on catastrophic forgetting: section 7.8.1).

Example. The generalization can be observed if features are activated which do not fit together in the description of a known object. This situation simulates the encounter of unknown exemplar, which shares several features common to the ones present in the training dataset.

Let us assume that, in the example used to illustrate the autoassociation property (section 6.2), the feature TOW also is activated (cf. figure 6.7a). Thus, the network should classify an unknown object which has the features TRACKED, HOT and TOW. The network converges in this case to the more general term which could be labelled as *antitank vehicle*. Thus, the general description for object carrying similar descriptions is activated. The final state of the network is shown on the figure 6.7b.

6.4 Cup or Bowl: Fuzzy Categorization

Following the series of introductory experiments showing the basic properties of the presented model, this section describes a simula-

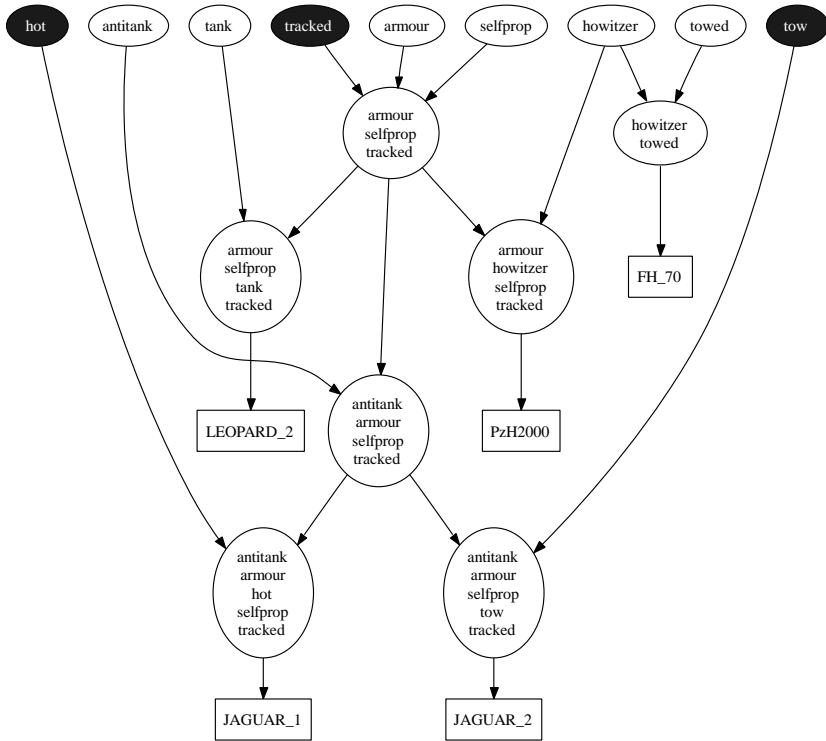

Figure 6.7a: Starting point for generalization process.

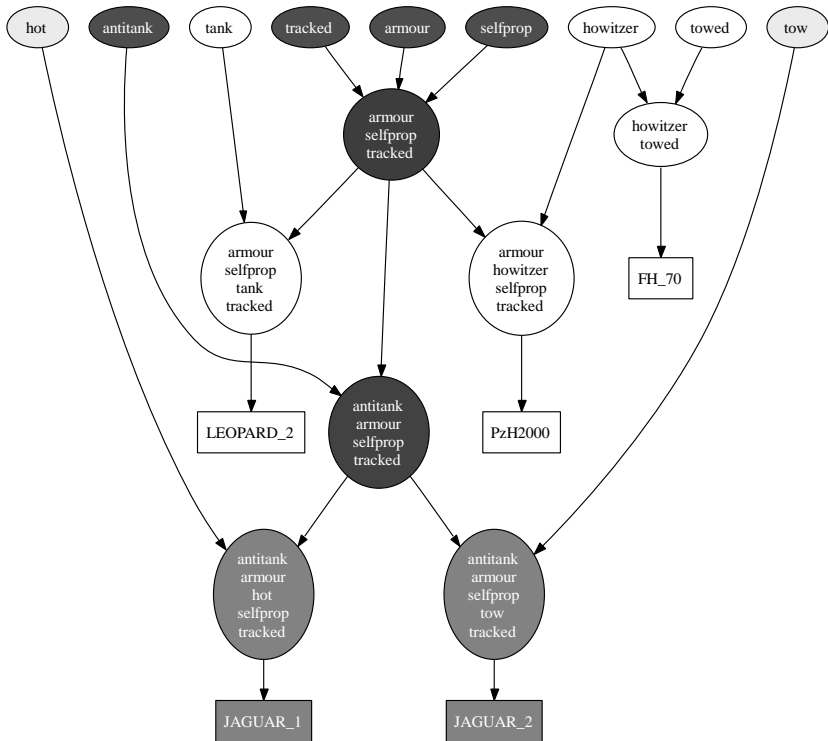

Figure 6.7b: Autoassociation successful in case of contradicting features: network converges to the more general term, here presented by the node “antitank, armour, selfprop, tracked”

tion based on the original experiment on boundaries of meanings of words conducted by Labov.

The aim of the simulation is to compare the behavior of the network against the experiments performed on human subjects, and thus to judge whether the model presented here catches selected properties of human cognition.

6.4.1 Original Experiment

The original experiment to be simulated here was described by Labov (1974). The results presented then shed a new light on the ideas of categorization of words' meanings. This was the first serious series of experiments which gave new insight into the categorization process. The formation of categories had until then been not being studied but rather the process had been assumed and "ready-to-use" categories utilized in the linguistic investigations.

The aim of this experiment was to investigate the boundaries between meanings of words rather than meaning itself. While it is very complicated to analyze the meaning of a single concept, distinguishing between two of them seems to be relatively simpler task. From a technical point of view, the act of naming "which associates a linguistic sign with an element of the extra-linguistic world" (Labov, 1974, p. 347) was studied. The naming experiment was based upon a series of drawings of cup-like objects, varying in

sizes and shapes (cf. figure 6.8). The experiment was conducted in the following way:

“The drawings of cups are presented to subjects one at a time, in two different randomized orders; the subjects are simply asked to name them. They are then shown the same series of drawings again, and this time asked to imagine in each case that they saw someone with the object in his hand, stirring in sugar with a spoon, and drinking coffee from it (or in some languages, tea), and to name them in this context. In a third series, they are asked to imagine that they came to dinner at someone’s house and saw this object sitting on the dinner table, filled with mashed potatoes (rice for some languages). (...) We will refer to these (...) contexts as the ‘Neutral’, ‘Coffee’, ‘Food’ (...) contexts. (...) The responses to these tests are in the form of noun phrases, often with a wide range of modifiers. In our present analysis, we consider only a head noun.” (Labov, 1974, p. 355)

The above-described procedure was conducted on several dozens of subjects and for a wide language spectrum. On the whole, the investigation of boundaries of meaning took over ten years to complete.

6.4.2 Simulation

Input Data and Simulation Setup

Based on the above-presented famous experiment by Labov, a test was conducted in order to discover the behavior of the network in the categorization task. The network was trained to categorize four cup-like objects presented in the figure 6.8 and additionally the fifth one not depicted, which had an even bigger diameter.

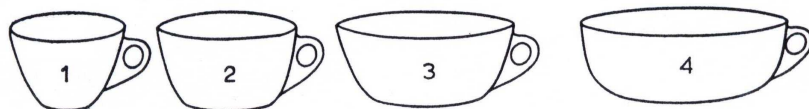

Figure 6.8: Drawings used for simulation of Labov’s experiment. Adapted from Labov (1974).

As input data, of course, not the pictures themselves were used but characteristics drawn from them, namely the dimensions of objects. Those dimensions — cup’s top and bottom diameters as well as height — were measured in centimeters with the accuracy of 1 mm. The measurement results as well as the “object — category” assignment for the learning phase are given in table 6.3.

The network however was not trained on absolute values but on ratios expressing correspondence between the mentioned dimensions. This was motivated by the fact that people are able to recognize objects based on the shape only, regardless of the absolute dimensions they have. For example, a real car and a car in a picture in a book are correctly named as an instance of the

a)				b)		
object id	dimensions			object id	context	
	<i>bottom</i>	<i>top</i>	<i>height</i>		neutral	food
1	1.0	2.2	1.6	1	cup	cup
2	1.7	2.64	1.6	2	cup	cup
3	2.2	3.3	1.6	3	cup	bowl
4	2.7	4.18	1.6	4	bowl	bowl
5	3.0	5.5	1.6	5	bowl	bowl

Table 6.3: Data used for simulation of Labov’s experiment: a) dimensions of objects, b) assigned categories in two contexts.

“car” category, or distant objects which seem to be smaller are as equally well categorized as those present nearby. This suggests that it is appropriate or even better grounded to use the relations between an object’s dimensions, which describe the shape, for the learning task. The ratios used were $\frac{bottom}{top}$, $\frac{height}{top}$ and $\frac{height}{bottom}$.

The training data was organized into vectors containing an *id* for the object in question as well as all three above-mentioned ratio values. (An object’s *id* is its unique identifier.) For example, the vector: $(1, \frac{5}{11}, \frac{8}{11}, 1.6)$ is a valid input.

In the experiment a set of 500 networks were used. A single network simulates a subject in the Labov’s experiment. It was trained on the set of data created as described above. Then connection weights were randomly changed up to a difference of 25% in value. These changes were meant to correspond to individual experiences of people: a change in weight means a change in sensitivity to the stimulus.

Method

For each of the 500 networks with modified weights the following simulation steps were conducted:

- for each dataset the feature nodes were activated with corresponding values, provided as input vector coordinates,
- activation was spread for 100 steps (the step number was chosen that high to assure a stable final activation pattern),
- the sum of activation of nodes corresponding to learned exemplars was calculated,
- a network was said to categorize an item as a “cup” when the sum of activation for nodes corresponding to learned cup objects was higher than the one corresponding to learned bowl objects, and as a “bowl” otherwise.

For each dataset the cumulative number of categorizations as “cup” and as “bowl” by all networks was stored separately and expressed as percentage of overall number of categorization acts.

Complementary Experiments Additionally, three complementary simulations were conducted in order to investigate another property of the network, namely the priming phenomenon. These additional simulations were conducted to examine the influence of situational context as well as of previous categorization on results of the current one.

In the first experiment the influence of a context was checked. An additional feature “context” was introduced (cf. table 6.3b). It had the meaning of neutral or of food context¹.

In two further simulations the networks underwent another procedure in order to check the influence of previous categorization act. The system categorized a test object after categorizing either an object which was a cup or a bowl first.

Results

The results of the categorization experiments are gathered in tables 6.4 and 6.5 and presented as graphs (figures 6.9 and 6.10). The resulting data expresses the probability of classifying an object as a “cup” or “bowl” against ratio of bottom width of the object in question to the bottom width of the first object in two different contexts. This form of presentation is chosen to allow direct comparison against the results as presented in the original work (Labov, 1974). The probability is given here as a percent [%] of the overall number of categorization acts.

For direct comparison the figure 6.11 which presents the original results obtained by Labov in 1974 in naming experiment conducted on eleven subjects (cf. subsection 6.4.1) is included here.

¹The meaning of a “context” in this case is explained in the quotation on the page 161.

width ratio	categorization probability [%]	
	cup	bowl
1	100	0
1.2	100	0
1.5	73.51247601	26.48752399
1.9	12.28733459	87.71266541
2.5	6.862745098	93.1372549

Table 6.4: Results of simulation of Labov’s experiment (neutral context).

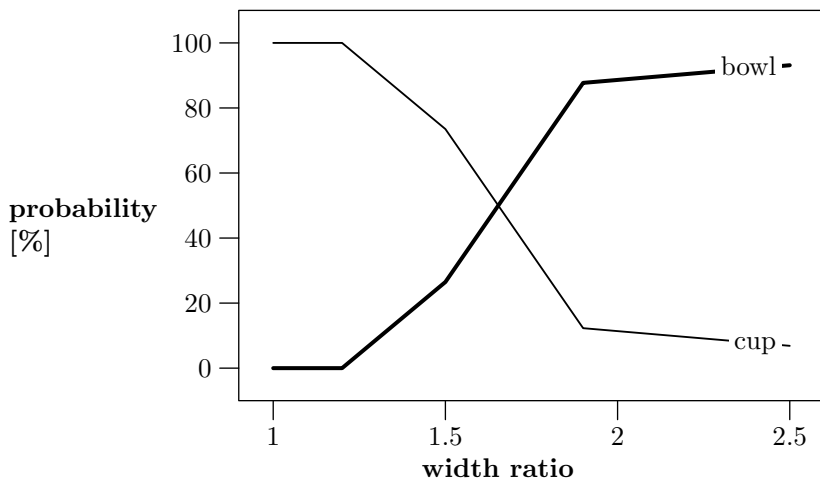

Figure 6.9: Results of simulation of Labov’s experiment (neutral context).

Experiment Discussion

The human categorization process is influenced by numerous factors. Thus it is not possible to fully simulate it in this simple simulation. The categorization process bases on much more data

width ratio	categorization probability [%]	
	cup	bowl
1	100	0
1.2	62.76803119	37.23196881
1.5	11.39489194	88.60510806
1.9	0	100
2.5	0	100

Table 6.5: Results of simulation of Labov's experiment (food context).

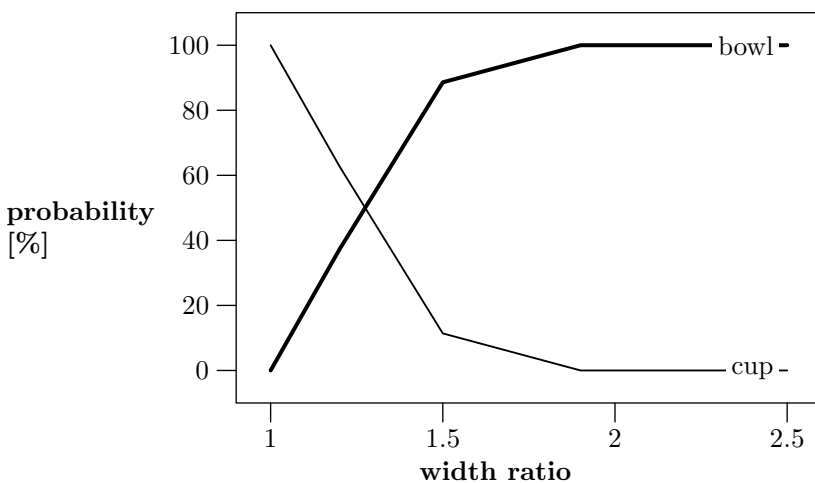

Figure 6.10: Results of simulation of Labov's experiment (food context).

and constraints that simple dimension ratios of objects in question. However, the *qualitative* similarities between the results from the network simulation and the original experiment are obvious. Both studies show the vagueness of the border between categories of cups and bowls.

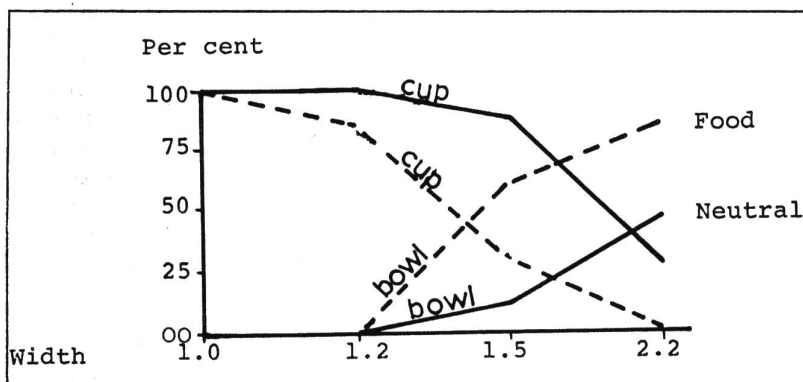

Figure 6.11: Original figure from Labov (1974), page 356.

Depending on the widths ratio the networks as well as the subjects in Labov's experiment tended to classify with a given probability. Thus the category boundary is not sharp, and there are no clear-cut differences between the meanings of the words. In all experiments, there are wide width ratio ranges to be observed where, for a given, ratio different networks tend to classify objects as either a cup or as a bowl.

The obtained results are sufficient to judge that the presented network is able to capture the behavior of the human categorization process: the boundary between categories identified by the network is not fixed and the categories are blended. This is in agreement with significant psychological findings showing that human categorization is not based on a set of necessary and jointly sufficient rules.

6.5 Cats Could Be Dogs

This simulation explores the properties of category learning by infants. It is based on the idea of an experiment presented by Quinn et al. (1993) which investigates category formation in early infancy.

6.5.1 Original Experiment

The original series of experiments concerns about the creation of the representation of perceptually similar categories in the early infancy, and was presented by Quinn et al. (1993). In one of the experiments the authors

“(...) explored the ability of infants to differentiate categorical representations of dogs from specific instances of cats and categorical representations of cats from specific instances of dogs.” (Quinn et al., 1993, p. 471)

This test trial showed that the novelty preference scores for infants familiarized with cats was greater than for those familiarized with dogs. The difference was substantially higher than statistical effects. One “explanation of this difference lies in a possible asymmetry in the structure of the two categories” (Quinn et al., 1993, p. 472).

The following simulation explores the formation of perceptually similar categories of dogs and cats with use of the connec-

tionist system presented in this paper. The main factor of this experiment is the investigation of asymmetry in the developed categories.

6.5.2 Simulation

The simulation was designed to test whether the network is able to develop a category representation which has the property discovered by Quinn et al.

Input Data and Simulation Setup

Like in the previously described simulation of Labov's experiment (section 6.4), the original data in form of pictures obviously could not be used in the following simulation because the network is not equipped with any kind of mechanism to analyse pictures directly. In the simulation made, therefore, the dataset used by Mareschal et al. (2000) was reused. This data consists of measurements of the most crucial properties of the original pictures. Table 6.6 shows the measurements for cat images, table 6.7 for dog images.

Based on the data gathered in tables, vectors were created with respective measurement values used as components. Those vectors were then normalized to the unitary length. The normalization expresses again the fact, that rather the shape, and thus only relations among different dimensions, is important, and not the absolute values.

exemplar	head length	head width	eye separation	ear separation	ear length	nose length	nose width	leg length	vertical extent	horizontal extent
cat1	29	32	7	28	12	0	3	0	54	62
cat2	12	13	4	12	5	3	2	14	25	50
cat3	20	20	4	17	6	5	3	15	26	67
cat4	13	17	4	17	5	3	2	28	28	46
cat5	13	14	4	14	4	4	3	15	23	42
cat6	18	22	3	17	6	6	3	24	42	70
cat7	10	12	3	7	3	2	1	24	24	47
cat8	23	24	5	26	7	4	4	25	50	64
cat9	16	17	4	15	5	5	4	22	32	54
cat10	16	15	3	12	8	3	2	15	30	65
cat11	19	27	5	20	8	4	3	22	71	57
cat12	19	21	4	12	5	5	4	20	39	65
cat13	25	30	6	30	14	6	5	0	50	81
cat14	16	20	3	16	13	5	3	26	29	59
cat15	17	27	5	22	5	3	3	28	40	43
cat16	18	21	4	20	6	4	4	35	55	43
cat17	23	22	5	24	7	6	4	35	52	56
cat18	20	22	5	23	7	5	4	28	34	54

Table 6.6: Data for cats in “cats and dogs” experiment (sizes in mm).

exemplar	head length	head width	eye separation	ear separation	ear length	nose length	nose width	leg length	vertical extent	horizontal extent
dog1	16	22	0	0	16	6	7	25	21	53
dog2	23	16	0	2	8	5	8	35	21	42
dog3	16	16	4	13	5	7	6	25	26	64
dog4	20	24	4	11	7	10	10	29	22	47
dog5	15	22	4	0	20	10	6	31	34	55
dog6	13	15	3	4	8	6	4	25	19	41
dog7	15	20	3	5	9	8	5	28	26	60
dog8	13	9	4	12	8	7	5	19	20	49
dog9	15	21	3	10	19	3	3	32	20	46
dog10	33	30	11	37	12	3	4	40	50	66
dog11	17	17	5	13	6	7	5	28	22	55
dog12	29	21	6	31	15	15	13	31	28	58
dog13	19	15	6	20	19	10	9	34	46	44
dog14	25	20	6	28	15	10	8	28	30	55
dog15	21	24	7	0	15	10	8	20	32	49
dog16	23	20	7	23	15	8	6	26	34	36
dog17	16	21	6	0	10	7	10	28	21	62
dog18	14	22	3	0	15	9	6	24	26	30

Table 6.7: Data for dogs in “cats and dogs” experiment (sizes in mm).

Method

The simulation was performed with two different networks trained under two different conditions (cf. figure 6.12):

- *trained on cats*: only data representing cats (12 items) was used, and
- *trained on dogs*: only data representing dogs (12 items) was used.

After training the network, the tests were performed using the remaining 6 objects. In this simulation, an *autoassociation property* of the network was utilised. For each set of features representing a cat or a dog, the respective feature nodes were activated and the activation was spread through the network for 50 steps. This step number was found by trial-and-error as giving a stable final activation pattern.

The results of the network operation were investigated in terms of the mean square error². The *mean square error* of an estimator $\hat{\theta}$ of a parameter θ in a statistical model is defined as:

$$\text{MSE}(\hat{\theta}) = \text{E}[(\hat{\theta} - \theta)^2] \quad (6.1)$$

From the definition of the variance

$$\text{Var}(X) = \text{E}(X^2) - \text{E}(X)^2 \quad (6.2)$$

²The following definition bases on <http://planetmath.org/encyclopedia/>

the mean square error can be expressed in terms of the bias by expanding the right hand side above:

$$\text{MSE}(\hat{\theta}) = \text{Var}(\hat{\theta}) + \text{Bias}(\hat{\theta}). \quad (6.3)$$

The *bias*, or systematic error, has to do with how the observations are made, how the instruments are set up to make the measurements, and most of all, how these observations or measurements are tallied and summarized to come up with an estimate of the true parameter. If $\hat{\theta}$ is an unbiased estimator, then its mean square error is identical to its variance:

$$\text{MSE}(\hat{\theta}) = \text{Var}(\hat{\theta}) \quad (6.4)$$

An unbiased estimator such that $\text{MSE}(\hat{\theta})$ is a minimum value among all unbiased estimators for θ is called a *minimum variance unbiased estimator*, abbreviated *MVUE*, or *uniformly minimum variance unbiased estimator*, abbreviated *UMVU* estimator.

The activation spreading was followed by the consequent procedure: the activation values for feature nodes were read and a mean squared error was calculated according to the following formula:

$$\text{MSE} = \frac{1}{N} \sum_{i=0}^N (a_i - f_i)^2 \quad (6.5)$$

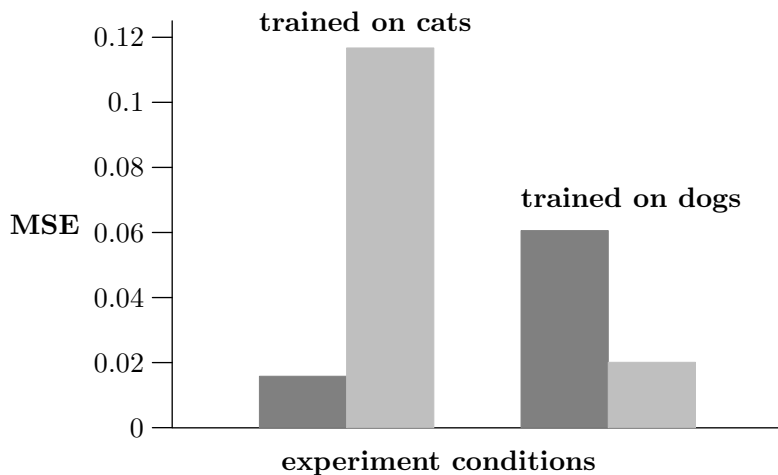

Figure 6.12: Result of “cats and dogs” experiment (explanation in text).

where MSE – mean squared error value, N – total number of feature nodes, a_i – i -th feature node’s activation value and f_i – value corresponding to the i -th feature in the set describing the item in question.

The meaning of MSE in this implementation can be explained as follows. The zero value of MSE means that an object has been perfectly recognized: the network reproduces a description for the object. The higher the value is, the larger is the difference between object’s real description (taken from tables 6.6 and 6.7) and description reproduced by network. A high difference, thus, expresses the fact that the object in question is poorly recognised or completely *not known*. In other words it expresses *the degree of the item’s novelty*.

Results and Experiment Discussion

The figure 6.12 shows the result of the experiment in terms of MSE. The dark bars correspond to network answers on stimulus associated with test cat items while the lighter ones correspond to the test dog items.

In the first setup the network was trained on cats only, and during the test phase consequently the mean square error was considerably higher for novel dogs than for novel cats. In the second setup, the network was trained on dogs only, but this time novel cats caused only little more errors than novel dogs had before. Thus, the network developed the representation of dog and cat categories with asymmetric exclusivity. It means that for a trained network it is more likely to categorize a cat as a dog than the other way round. This finding is consistent with results of the Quinn et al.'s experiment performed on infants.

The further statistical investigation on the reasons of the asymmetric category learning phenomenon in the presented experiment can be found in (Mareschal and French, 2000; Mareschal et al., 2000).

The following chapter summarizes and provides comments on the features of the model presented in this work. These features were observed in the experiments described above.

CHAPTER 7

Model Properties

This section presents an overview over the properties of the presented network. It starts from simple properties of the network itself and leads to the cognitive properties of the network's performance.

7.1 Description Autocompletion and Noise Reduction

Autoassociation is a special case of associative memory. Quite simply the input patterns are associated with a copy of themselves on the output units. (Ellis and Humphreys, 1999, p. 46)

The developed network manifests *autoassociation* (autocompletion). When given a part of a description (an incomplete set of features) it attempts to complete it in the best possible way. That means it recalls the features set (in the way that it activates corresponding nodes) for which the given features are most distinctive. This is possible even if only one feature is given as long as this feature is distinguishing.

The *noise reduction property* is displayed in a case when the network is fed with data containing features that should not co-occur with other ones. If some features define a class to a sufficient extent, the corresponding pattern is reproduced and the activation of the “noisy” features is canceled.

Autoassociation property is well known in connectionist modeling (cf. chapter “Autoassociation” in McLeod et al., 1998). However, all well-known autoassociator architectures use distributed data representation and thus fall under the category of distributed connectionism. The system proposed here is as far as I know the only localist system able to learn autoassociations.

7.2 Generalization

Generalization takes place when the given data contain features that contradict each other on some level but still correspond to nodes in the same taxonomy branch. In this situation a network converges to the feature pattern describing the superclass which is common for all nodes partially described by given data. In other

words the network finds the more general term to describe the presented set of features.

Generalization is seen as one of the most important advantages of the connectionist models. It allows for learning and for proper reaction to the previously unknown data.

For this mechanism, the discovery of common features is crucial. It allows for correct classification of novel datasets. Moreover, the system may enhance the taxonomy by the newly encountered object in case its featural description is verified.

The strength and weakness of the localist connectionist models often boil down to increased interpretability at the expense of the model's ability to automatically generalize across patterns. For engineering uses of connectionist models, generalization might be the more important property. (Goldstone, 1998, p. 321)

My model goes towards overcoming these issues. It is both clearly interpretable as well as able to generalize and either during learning or the performance phase.

7.2.1 Overfitting

A dangerous phenomenon connected to the generalization ability is called *overfitting*.

If the training data is considered to consist of both signal and noise (i.e., noisy data), a modeling tech-

nique has begun to overfit when it begins capturing the “noise” instead of the “signal”. (...) The effect of overfitting is to reduce the applicability of the model to other data sets (i.e., to limit its generalizability). (Raynor, 1999, p. 219)

In other words, a system which “overfits” is unable to generalize properly, that is to correctly react to the new data. The solution proposed here is not threatened by overfitting for at least two reasons. Overfitting emerges only in distributed connectionist networks with too many free parameters in comparison to the training data. In the network presented here, the localist representation is used. It assures that only the existing nodes will be selected, thereby avoiding that the network produces noise data.

7.3 Family Resemblance

In the resulting network not all members of a category must have features common to the other members. Membership is based on family resemblance, which was first suggested in philosophy by Wittgenstein (1971).

“A family resemblance relationship consists of a set of items of the form AB, BC, CD, DE. That is, each item has at least one, and probably several, elements in common with one or more other items, but no, or

few, elements are in common to all items.” (Rosch, 1975b, p. 575)

Family resemblance means only that an object within the same category must be similar to at least one other object, but not that all objects in a given category must resemble one another. The family resemblance can be measured in the model presented in the terms of activation values: the smaller the difference between activation values of two nodes on the same taxonomical layer, the higher their family resemblance.

7.4 Fuzzy Categorization

Human categorization does not follow rules based on necessary and sufficient conditions. In contrast, the categorization process exhibits many interesting properties, one of which is fuzzy categorization. It means that category boundaries are not arbitrarily fixed and also can change along with external conditions. In particular, different people can categorize the same object in different ways, which are dependent on either conditions like context or on previous experiences.

Based on the experiment by Labov (1974), a test was conducted in order to discover the behavior of the network in categorization tasks. The network was trained to categorize 5 cup-like objects. As in the original experiment, the results show that categorization is an ambiguous process. There is no clear-cut border

between investigated objects, and those which are categorized as cups by some people (networks) can be treated as bowls by others.

7.5 Priming

“Priming refers to an increased sensitivity to certain stimuli due to prior experience. Because priming is believed to occur outside of conscious awareness, it is different from memory that relies on the direct retrieval of information. Direct retrieval utilizes explicit memory, while priming relies on implicit memory. Research has also shown that the affects of priming can impact the decision-making process.” (Jacoby, 1983)

Context-based priming is a particular case of priming when the associations are activated by a context in which the given stimulus should be processed. It was observed in the experiment described above. Depending on the context (neutral or “food”) the probability to classify a given object as a cup or a bowl differs.

Another type of priming, the one driven by previous categorization was also simulated. In this case, the priming procedure investigated concerns so-called semantic priming: the phenomenon that presentation of a word will boost categorization probability for a semantically-related word. Semantic priming is the only priming possible to model in this experiment, because all catego-

rized items are more or less semantically related. This relation is expressed then in terms of overlapping features.

The results of the priming experiment clearly showed the expected phenomenon: the change in probability to categorize an object as a cup or as a bowl under the system's prior exposure to information in the decision context as well as in this case on previously performed categorization. This dependency decays with time as expected.

7.6 Lexical Items

The connectionist network being described contributes also to models of representation of lexical items.

“[T]he lexical item serves a central controlling and stabilizing role in language learning and processing.”

(MacWhinney, 2000, p. 134)

This means that lexical items associate different grammatical, semantic, phonological, perceptual and possibly also other features.

“The lexical hypothesis entails, in particular, that nothing in the speaker's message will *by itself* trigger a particular syntactic form (...). There must always be mediating lexical items, triggered by the message (...).” (Levelt, 1989, p. 181)

A class node in the network plays exactly the same role. It creates a link between different feature nodes. The lexical item

representation has its origin in the autoassociation property of the network as well as in its highly localist nature.

The advantage over MacWhinney's solution using self-organizing maps (Kohonen, 1982; Miikkulainen, 1990) is that this network is able not only to tie different types of features together but also delivers a structure of the lexicon: that means items sharing similar features are not only close to each other but the hyponymy relation is preserved as well.

Other localist solutions, like for example those proposed by Stemberger (1985) or Dell (1986), despite their focus on a central role of the lexical item, have the common drawback of typical localist architecture. They are handwired and are unable to react to new or changing data. The model presented overcomes this shortcoming (cf. section 7.8).

7.7 Asymmetric Category Learning

The experiment conducted by Quinn et al. (1993) inspired the investigation of the properties of category formation process. This experiment covered two issues: category formation as such, as well as the exclusivity asymmetry in category representations. Quinn (2002, p. 67) states:

“Generalization of familiarization to the novel instance from the familiar category and a reference for the novel instance from the novel category (measured in looking

time) are taken as evidence that the infants have on some basis grouped together, or categorized, the instances from the familiar category and recognized that the novel instance from the novel category does not belong to this grouping (or category representation).”

The asymmetry was observed because of the distribution of cat and dog feature values in the stimuli presented to the infants (Mareschal et al., 2000). Feature values for cats often fell within the range of values for dogs but not the other way round. Thus for a system that processes the statistical distribution of features of a stimulus, the cats would appear as a subset of the dog category.

Thus infants are able to form a category representation and, moreover, this representation displays exclusivity asymmetry. The test with a network gave qualitatively similar results. The network developed the representation of dog and cat categories with asymmetric exclusivity. The model demonstrates that categorical representations can self-organize as a result of exposure to familiarization exemplars.

7.8 Localism and Distributionism

The difference between localist and distributed connectionist models is first seen in their architectures, which is the result of the different kinds of information representations used. Beside the architectural issues, the separation of localist and distributed models can be seen in the distinction between theories of learning and

theories of performance. The distributed models are generally seen as a tool for the investigation of learning processes, while the localist ones place greater importance on performance (cf. Grainger and Jacobs, 1998, p. 6-10). The network presented here is neither purely localist nor purely distributed. It is a step towards covering both aspects of cognitive processes: learning and performing. It comes with a learning mechanism — like distributed architectures — as well as has the representational power typical for localist systems.

From the architecture point of view the network is localist in the sense that each node can have its own interpretation independent from the state of the whole network. It is additionally localist in that class nodes represent single entities which can be referred to by name. It is however also of a distributed nature because in most network architectures the representation of any class would consist of multiple nodes activated on a given level of network. I use the word “level”, but “level” cannot be defined clearly. The network is not structured in layers, as most classical (localist and distributed) networks are. A set of nodes described by an equal number of co-occurring features can be taken as a layer. However, in this case inhibitory connections exist not only between nodes on the same level but also between nodes on different levels.

7.8.1 Comparison against PDP-networks

The parallel distributed processing (PDP) paradigm (Rumelhart et al., 1986b) has been widely used in cognitive modeling (cf. for example Kruschke, 1992; Mareschal et al., 2000; Plaut and Botvinick, 2004; Rouder et al., 2000). However this approach has some drawbacks. The most important problems concern the increasing volume of knowledge. The usual PDP network once trained cannot adapt to new data: it suffers from catastrophic forgetting (French, 1999) (new data overwrites that already learned) and often simply lacks storage space because of limited number of nodes. The other problem is that the architecture (number of layers, number of nodes, connections configuration etc.) of such networks is found by trial and error and almost always arbitrary.

The network presented here is a step toward overcoming these issues. It is a constructivist architecture which “regards development as consisting of directed construction of representations through interaction with a structured environment, and so involving a progressive increase in representational capacity” (Quartz and Sejnowski, 1997, p. 541), which means here that it can expand and adapt to the growing amount of data. Also, as a partially exemplar-based network using *localist* representation, it does not suffer from catastrophic forgetting. The network can organize itself and adapt to the structure of the data and thus its architecture is no longer hand-crafted and arbitrary but emerges logically from the underlying data. Additionally the architecture created in this

way has a great representational power because it corresponds directly to the taxonomy of objects used in the learning phase. This representational power is not directly accessible within networks using a distributed representation because getting the information usually demands a complex analysis of the states of all nodes.

The proposed network suffers seemingly from a scalability problem. The number of nodes and the time needed to simulate such a network on a computer increases with the volume of input data. (It is, however, not possible to estimate in general the increase because it strongly depends on how the input data is structured.) In contrast, the usual PDP networks have fixed numbers of nodes and connections and thus the simulation time is also constant. In my opinion, however, this problem should be seen as a problem of the tools used for network simulation (computers). The networks from their nature are fully parallel architectures and each node should work independently at the same time, which obviously is not the case in the computers running the network simulations. This is why I assume that the mentioned scalability problem does not really concern the network itself, but simply is a result of limitations of tools used to simulate the networks.

7.9 Biological Inspiration

As is the case for each network having localist traces, the biological plausibility of the network presented here can be questioned. This is why I would rather talk about biological inspiration than

plausibility. It is clear that in the brain there are no single neurons corresponding to single concepts or combinations of concepts. However, Page (2000) states that distinct populations of neurons (e.g. cortical minicolumns) can have similar representation properties as nodes of a localist network. In this view, the use of semi-localist representation can be justified (cf. Schade, 2002).

What makes the network even more inspired by biology is the structure of a node. Unlike those usually used in both distributed and localist models, the node has its internal structure. The neuron is not an object only capable of single operations (such as summing or integrating) on the incoming signal, it can also perform much more complex calculations. The same is true for a node in the model presented.

With respect to connections between nodes, it should be noted that, although they are symmetric in their weights, the signal flowing from node A to node B should not be processed exactly in the same way as the one flowing from node B to node A. This has its origin in the fact that even if two neurons are mutually connected, two different axons and two different sets of dendrites are engaged.

CHAPTER 8

Conclusions

The categorization process is one of the most important cognitive tasks. This means that modeling of cognitive processes must include a mechanism allowing for the categorization as close to human categorization as possible. The categorization model must perform well but should provide a mechanism to interact with new data encountered during the operation (learning).

In this work a spreading activation network has been presented, which is capable of representing relations between concepts described by non-binary features. The network contributes to cognitive modeling by providing a constructivist learning method (cf. page 125) for automatic and unsupervised creation of a taxonomy.

This connectionist system is not a complete solution for modeling cognitive aspects of categorization processes but contributes to the connectionist models of investigations in cognition in the following ways.

- The “standard” connectionist network is enhanced with the complex node’s internal structure.
- The network can not only perform but also react to new data by means of constructivist restructuring. The network undergoes self-organization to create the taxonomy as well as attempts to enrich this taxonomy with new terms which are discovered automatically by the system itself.
- The algorithm used shows that also networks using local data representation are able to learn and to generalize.
- The structure of the network allows for building hierarchical “lexica” containing items defined by sets of features.

Moreover, the network is able to display cognitive behavior like, for example, fuzzy categorization and priming. Also, in the category acquisition process it displays similar properties to those in category representation learning by infants.

The model was evaluated in a series of experiments (chapter 6). The results of network’s performance were compared against data gathered during “real-world” psychological and psycholinguistical experiments. The qualitative result of these comparisons shows

high conformity. Thus, it is legitimate to state that the presented model contributes to investigations in the nature of cognition.

Bibliography

- C. Amerijckx, J.-D. Legat, and M. Verleysen. Image compression using self-organizing maps. *Systems Analysis Modelling Simulation*, 43(11):1529–1543, 2003. ISSN 0232-9298.
- J. Anderson. A simple neural network generating an interactive memory. *Mathematical Biosciences*, 14:197–220, 1972.
- J. A. Anderson and M. Mozer. Categorization and selective neurons. In G. E. Hinton and J. A. Anderson, editors, *Parallel Models of Associative Memory*, pages 251–274. Erlbaum, Hillsdale, NJ, 1989.
- J. R. Anderson and G. H. Bower. *Human Associative Memory*. Winston, Washington, DC, 1973.

- John M. Anderson. *Linguistic Representation. Structural Analogy and Stratification*. Mouton de Gruyter, Berlin, 1992.
- John M. Anderson and Jacques Durand. Dependency phonology. In Jacques Durand, editor, *Dependency and non-linear phonology*, pages 1–54. Croom Helm, London, 1986.
- John R. Anderson. A spreading activation theory of memory. *Journal of Verbal Learning and Verbal Behavior*, 22:261–295, 1983.
- Aristotle. Categories. In W. D. Ross, editor, *The Works of Aristotle translated into English, Volume I*. Oxford University Press, Oxford, 1928.
- Aristotle. Metaphysics. In W. D. Ross, editor, *The Works of Aristotle translated into English, Volume VIII*. Oxford University Press, Oxford, 1908.
- F. Gregory Ashby and W. Todd Maddox. Human category learning. *Annual Review of Psychology*, 56:06.1–06.30, 2005.
- Lawrence W. Barsalou. *Cognitive psychology: An overview for cognitive scientists*. Erlbaum, Hillsdale, NJ, 1992.
- Thomas Berg. *Die Abbildung des Sprachproduktionsprozesses in einem Aktivationsflußmodell*. Niemeyer, Tübingen, 1988.
- Thomas Berg and Ulrich Schade. The role of inhibition in a spreading-activation model of language production. i. the psy-

- cholinguistic perspective. *Journal of Psycholinguistic Research*, 21:405–434, 1992.
- Brent Berlin. *Ethnobiological Classification: Principles of Categorization of Plants and Animals in Traditional Societies*. Princeton University Press, Princeton, NJ, 1992.
- Daniel G. Bobrow. Natural language input for a computer problem solving program. In Marvin Minsky, editor, *Semantic Information Processing*. MIT Press, 1969.
- Ronald J. Brachman. On the epistemological status of semantic networks. In N. V. Findler, editor, *Associative Networks: Representation and Use of Knowledge by Computers*, pages 3–50. Academic Press, New York, 1979.
- Ronald J. Brachman and James G. Schmolze. An overview of the KL-ONE knowledge representation system. *Cognitive Science*, 9:171–216, 1985.
- Ronald J. Brachman, Deborah L. McGuinness, Peter F. Patel-Schneider, and Lori A. Resnick. Living with CLASSIC: when and how to use a KL-ONE-like language. In John Sowa, editor, *Principles of semantic networks*. Morgan Kaufmann, San Mateo, US, 1990. URL citeseer.ist.psu.edu/brachman91living.html.

- Lee R. Brooks. Nonanalytic concept formation and memory for instance. In Erlbaum, editor, *Cognition and categorization*. E. Rosch and B. Lloyd, Hillsdale, NJ, 1978.
- D.S. Broomhead and D. Lowe. Multivariable function interpolation and adaptive networks. *Complex Systems*, 2:321–355, 1988.
- Susan Carey. Semantic development, state of the art. In L. Gleitman and E. Wanner, editors, *Language Acquisition, State of the Art*, pages 347–389. Cambridge University Press, Cambridge, 1982.
- Gail A. Carpenter and Stephen Grossberg, editors. *Pattern Recognition by Self-Organizing Neural Networks*. MIT Press, Cambridge, MA, USA, 1991. ISBN 0262031760.
- Silvio Ceccato. *Linguistic Analysis and Programming for Mechanical Translation*. Gordon and Breach, New York, 1961.
- Noam Chomsky and Morris Halle. *The Sound Pattern of English*. Harper and Row, New York, 1968.
- M. H. Christiansen and N. Chater. Generalization and connectionist language learning. *Mind and Language*, 9(273-287), 1994.
- Eve V. Clark. What's in a word? on the child's acquisition of semantics in his first language. In T.E. Moore, editor, *Cognitive Development and the Acquisition of Language*, pages 65–110. Academic Press, New York, 1973.

- G. N. Clements and E. V. Hume. The internal organization of speech sounds. In J. A. Goldsmith, editor, *The Handbook of Phonological Theory*. Blackwell Publishers, Cambridge, MA, 1995.
- Allan Collins and Elisabeth Loftus. Spreading activation theory of semantic processing. *Psychological Review*, 82:407–428, 1975.
- Allan M. Collins and M. Ross Quillian. Retrieval time from semantic memory. *Journal of verbal learning and verbal memory*, 8:240–247, 1969.
- D. A. Cruse. The pragmatics of lexical specificity. *Journal of Linguistics*, 13:153–164, 1977.
- R. Daniloff and R. Hammarberg. On defining coarticulation. *Journal of Phonetics*, 1:239–248, 1973.
- G. S. Dell, M. F. Schwartz, N. Martin, E. M. Saffran, and D. A. Gagnon. Lexical access in aphasic and nonaphasic speakers. *Psychological Review*, pages 801–939, 1997.
- Gary S. Dell. A spreading-activation theory of retrieval in sentence production. *Psychological Review*, 93(3):283–321, 1986.
- Z. Dienes. Connectionist and memory array models of artificial grammar learning. *Cognitive Sciences*, 16:41–79, 1992.
- Robert M. W. Dixon. Where have all the adjectives gone? In R. M.W. Dixon, editor, *Where Have All the Adjectives Gone?*

- and Other Essays in Semantics and Syntax*, pages 1–62. Mouton, Berlin-Amsterdam-NewYork, 1982.
- Rob Ellis and Glyn Humphreys. *Connectionist Psychology. A Text with Readings*. Psychology Press, 1999.
- J. Elman. Finding structure in time. *Cognitive Science*, 14:179–212, 1990.
- T. Evans. A program for the solution of a class of geometric-analogy intelligence test questions. In Marvin Minsky, editor, *Semantic Information Processing*. MIT Press, 1969.
- Charles J. Fillmore. Towards a descriptive framework for spatial deixis. In R. J. Jarvella and W. Klein, editors, *Speech, Place and Action*, pages 31–59. John Wiley & Sons, Londres, 1982.
- Robert M. French. Catastrophic forgetting in connectionist networks: causes, consequences and solutions. *Trends in Cognitive Sciences*, 3(4):128–135, 1999.
- Victoria A. Fromkin. The non-anomalous nature of anomalous utterances. *Language*, 47:27–52, 1971.
- Volker Gadenne. *Karl Popper, Logik der Forschung*, chapter Bewährung, pages 125–144. Akademie Verlag, 1998.
- F. J. Gall and J. G. Spurzheim. *Recherches sur le Systeme Nerveaux*. Bonset, Amsterdam, 1809/1967.

- Emden Gansner, Eleftherios Koutsofios, and Stephen North. Drawing graphs with dot. 2006. URL <http://www.graphviz.org/Documentation/dotguide.pdf>.
- Merril F. Garrett. The analysis of sentence production. In G. Bower, editor, *Psychology of learning and motivation: Volume 9*. Academic Press, 1975.
- Xijin Ge and Shuichi Iwata. Learning the parts of objects by auto-association. *Neural Netw.*, 15(2):285–295, 2002. ISSN 0893-6080. doi: [http://dx.doi.org/10.1016/S0893-6080\(01\)00145-9](http://dx.doi.org/10.1016/S0893-6080(01)00145-9).
- Dirk Geeraerts. Functional explanations in diachronic semantics. *Belgian Journal in Linguistics*, 1:67–93, 1986.
- Dirk Geeraerts. Prototypicality as a prototypical notion. *Communication and Cognition*, 21:343–355, 1988.
- Ashish Ghosh and Sankar K. Pal. Neural network, self-organization and object extraction. *Pattern Recognition Letters*, 13(5):387–397, 1992.
- Helmut Gipper. *Gibt es ein sprachliches Relativitätsprinzip?* Fischer, Frankfurt/M, 1972.
- Robert L. Goldstone. Hanging together: A connectionist model of similarity. In J. Grainger and A. M. Jacobs, editors, *Localist Connectionist Approach to Human Cognition*. Lawrence Erlbaum, Mahwah, NJ, 1998.

Jonathen Grainger and Arthur M. Jacobs. On localist connectionism and psychological science. In Jonathan Grainger and Arthur M. Jacobs, editors, *Localist connectionist approaches to human cognition*. Lawrence Erlbaum Associates, Mahwah, New Jersey, 1998.

GraphViz Website. Last access on 16.07.2007, 2007. URL <http://www.graphviz.org/>.

S. Graubard. *The Artificial Intelligence Debate: False Starts, Real Foundations*. MIT Press, Cambridge, Mass., 1988.

S. Grossberg. Adaptive pattern classification and universal recoding: I. parallel development and coding in neural feature detectors. *Biological Cybernetics*, 23:121–134, 1976.

J. A. Hampton. Concepts. In *MIT Encyclopedia of Cognitive Science*, pages 176–179. MIT Press, Cambridge, 1999.

Stevan Harnad. *Cognition is categorization*, 2003. <http://cogprints.org/archive/00003027/>.

Donald Olding Hebb. *The organization of behavior*. Wiley, New York, 1949.

Geoffrey Hinton and Terrence J. Sejnowski, editors. *Unsupervised Learning and Map Formation: Foundations of Neural Computation*. MIT Press, 1999.

- James R. Hurford and Brendan Heasley. *Semantics: A Coursebook*. Cambridge University Press, Cambridge, 2004.
- L. L. Jacoby. Perceptual enhancement: Persistent effects of an experience. *Journal of Experimental Psychology: Learning, Memory, and Cognition*, 9(1):21–38, 1983.
- A. K. Jain, M. N. Murty, and P. J. Flynn. Data clustering: a review. *ACM Computing Surveys*, 31(3):264–323, 1999. URL citeseer.ist.psu.edu/jain99data.html.
- Java Website. Last access on 16.07.2007, 2007. URL <http://java.sun.com/>.
- JBUILDER. Last access on: 16.07.2007, 2007. URL <http://www.codegear.com/products/jbuilder>.
- M. I. Jordan. Attractor dynamics and parallelism in a connectionist sequential machine. In *Proceedings of the Eighth Annual Meeting of the Cognitive Science Society*, pages 531–546. Erlbaum, Hillsdale, NJ, 1986.
- Michael I. Jordan. Why the logistic function? a tutorial discussion on probabilities and neural networks. Computational Cognitive Science 9503, MIT, 1995. URL <http://www.cs.berkeley.edu/~jordan/papers/uai.ps.Z>.
- Immanuel Kant. *Kritik der reinen Vernunft*. Felix Meiner Verlag, Hamburg, 1787/1990.

- R. Kavanaugh. On the synonymity of 'more' and 'less': comments on methodology. *Child Development*, 47:885–887, 1976.
- G. Kempen and P. Huijbers. The lexicalisation process in sentence production and naming: indirect election of words. *Cognition*, 14:185–209, 1983.
- Sharon E. Kingsland. *Modeling Nature: Episodes in the History of Population Ecology*. University of Chicago, Chicago, 2nd edition, 1995.
- Georges Kleiber. *Semantyka prototypu. Kategorie i znaczenie leksykalne (= La sémantique du prototype. Catégories et sens lexical)*. Universitas, Kraków, 2003.
- Christof Koch, Tomaso Poggio, and Vincent Torre. Retinal ganglion cells: a functional interpretation of dendritic morphology. *Philosophical Transactions of the Royal Society of London. Series B: Biological Sciences*, 298:227–263, 1982.
- Christof Koch, Tomaso Poggio, and Vincent Torre. Nonlinear interactions in a dendritic tree: localization, timing and role in information processing. In *Proceedings of the National Academy of Sciences of the United States of America*, volume 80, pages 2799–2802, 1983.
- Teuvo Kohonen. Correlation matrix memories. *IEEE Transactions on Computers*, C-21:353–359, 1972.

- Teuvo Kohonen. Self-organized formation of topologically correct feature maps. *Biological Cybernetics*, 43:59–69, 1982.
- Peter R. Krebs. Models of cognition: Neurological possibility does not indicate neurological plausibility. In Bruno G. Bara, Lawrence Barsalou, and Monica Bucciarelli, editors, *Proceedings CogSci 2005*, pages 1184–1189. Stresa, Italy, 2005.
- John K. Kruschke. ALCOVE: An exemplar-based connectionist model of category learning. *Psychological Review*, 99:22–44, 1992.
- William Labov. The boundaries of words and their meanings. In C.-J. Bailey and R. Shuy, editors, *New Ways of Analyzing Variation in English.*, pages 340–373. Georgetown U. Press., Washington, DC, 1974.
- P. Ladefoged. *A Course in Phonetics*. Harcourt Brace Jovanovich, New York, 1975.
- Krista Lagus, Timo Honkela, Samuel Kaski, and Teuvo Kohonen. Websom for textual data mining. *Artificial Intelligence Review*, 13(5-6):345–364, 1999. URL citeseer.ist.psu.edu/lagus99websom.html.
- George Lakoff. Classifiers as a reflection of mind. In C. Craig, editor, *Noun Classes and Categorization*, pages 13–51. John Benjamins, Amsterdam, 1986.

- George Lakoff. Hedges: A study in meaning criteria and the logic of fuzzy concepts. *Journal of Philosophical Logic*, 2:458–508, 1973.
- George Lakoff. *Women, fire, and dangerous things: What categories reveal about the mind*. University of Chicago Press, Chicago, 1987.
- J. Laver. *Principles of phonetics*. Oxford University Press, Oxford, UK, 1994.
- Steve Lawrence, C. Lee Giles, and Sandiway Fong. Natural language grammatical inference with recurrent neural networks. *IEEE Transactions on Knowledge and Data Engineering*, 12(1):126–140, 2000. URL citeseer.ist.psu.edu/lawrence98natural.html.
- Y. le Cun. A learning scheme for asymmetrical threshold networks. In *Proceedings of Cognitivia*, volume 85, 1985.
- W. J. M. Levelt, A. Roelofs, and A. S. Meyer. A theory of lexical access in speech production. *Behavioral and Brain Science*, 22: 1–75, 1999.
- Willem J. M. Levelt. *Speaking: From Intention to Articulation*. MIT Press, 1989.
- David A. Lieberman. *Learning Behavior and Cognition*. Brooks/Cole Publishing Company, Pacific Grove, California, 1992.

- Peter Liggesmeyer. *Software-Qualität. Testen, Analysieren und Verifizieren von Software*. Spektrum Akademischer Verlag, 2002.
- M. Lindau. Vowel features. *Language*, 54:541–563, 1978.
- J. Lubker. Temporal aspects of speech production: Anticipatory labial coarticulation. *Phonetica*, 38:51–65, 1981.
- Brian MacWhinney. Connectionism and language learning. In Michael Barlow and Suzanne Kemmer, editors, *Usage-Based Models of Language*, pages 121–149. CSLI Publications, Stanford, California, 2000.
- Denis Mareschal and Robert M. French. Mechanisms of categorization in infancy. *Infancy*, 2000.
- Denis Mareschal, Robert M. French, and Paul Quinn. A connectionist account of asymmetric category learning in early infancy. *Developmental Psychology*, 36(5):635–645, 2000.
- Margaret Masterman. Semantic message detection for machine translation, using an interlingua. In *1961 International Conference on Machine Translation of Languages and Applied Language Analysis*, pages 437–475, London, 1962. Her Majesty's Stationery Office.
- James McClelland and David Rumelhart. Distributed memory and the representation of general and specific information. *Journal of Experimental Psychology*, 114:159–188, 1985.

- James L. McClelland and J. L. Elman. Interactive processes in speech perception: The trace model. In J. L. McClelland and D. E. Rumelhart, editors, *Parallel distributed processing*, volume 2, pages 58–121. MIT Press, 1986.
- James L. McClelland and David E. Rumelhart. An interactive activation model of context effects in letter perception: Part 1. An account of basic findings. *Psychological Review*, 88:375–407, 1981.
- P. McCullagh and J. A. Nelder, editors. *Generalized Linear Models*. Chapman & Hall, 2nd edition, 1989.
- W. McCulloch and W. Pitts. A logical calculus of the ideas immanent in nervous activity. *Bulletin of Mathematical Biophysics*, 5/115, 1943.
- P. McLeod, K. Plunkett, and E. T. Rolls. *Introduction to connectionist modelling of cognitive processes*. Oxford University Press, 1998.
- D. L. Medin and M. M. Schaffer. Context theory of classification learning. *Psychological Review*, 85:207–238, 1978.
- David A. Medler. A brief history of connectionism. *Neural Computing Surveys*, 1:61–101, 1998.
- Bartlett W. Mel. Information processing in dendritic trees. *Neural Computation*, 6:1031–1085, 1994.

- D. Merkl. Text classification with self-organizing maps: Some lessons learned. *Neurocomputing*, 21(1–3):61–77, 1998.
- Risto Miikkulainen. A distributed feature map model of the lexicon. In *Proceedings of the 12th Annual Conference of the Cognitive Science Society*, pages 447–454, Hillsdale, NJ, 1990. Lawrence Erlbaum.
- John Milnor. On the concept of attractor. *Communications in Mathematical Physics*, 99:177–195, 1985.
- Marvin Minsky and Seymour Papert. *Perceptrons: An Introduction to Computational Geometry*. MIT Press, Cambridge, Mass., 1969.
- J. E. Moody and C. J. Darken. Fast learning in networks of locally-tuned processing units. *Neural Computation*, 1(2):281–294, 1989.
- M. T. Musavi, K. H. Chan, D. M. Hummels, and K. Kalantri. On the generalization ability of neural network classifiers. *IEEE Trans. Pattern Anal. Mach. Intell.*, 16(6):659–663, 1994. ISSN 0162-8828. doi: <http://dx.doi.org/10.1109/34.295911>.
- C. K. Ogden and I. A. Richards. *The Meaning of Meaning. A Study of the Influence of Language upon Thought and of the Science of Symbolism*. Harcourt, Brace and Brace, New York, 1923.

- Daniel N. Osherson and Edward E. Smith. On the adequacy of prototype theory as a theory of concepts. *Cognition*, 9:35–58, 1981.
- Martin Otto. *Algorithmic Model Theory for Specific Semantic Domains*, 2002. URL <http://www-compsci.swan.ac.uk/~csmartin/amt.html>.
- Mike Page. Connectionist modelling in psychology: A localist manifesto. *Behavioral and Brain Sciences*, 23:443–512, 2000.
- D. B. Parker. Learning logic. technical report 47. Technical report, MIT Center for Computational Research in Economics and Management Science, Cambridge, MA, 1985.
- Petrus Hispanicus. *Summulae Logicales (edited by I. M. Bocheński)*. Marietti, Turin, ca. 1239/1947.
- Terry F. Pettijohn. *Psychology: A ConnecText*. Mc Graw-Hill, 4th edition, 1998.
- David C. Plaut and Matthew M. Botvinick. Doing without schema hierarchies: A recurrent connectionist approach to normal and impaired routine sequential action. *Psychological Review*, 111: 395–429, 2004.
- Karl Popper. *Logik der Forschung*. Tübingen, 10. auflage edition, 1935/1994.

- Porphyry. Isagoge. In Paul Vincent Spade, editor, *Five Texts on the Medieval Problem of Universals*, pages 1–16. Hackett, Cambridge, 1994.
- Steven R. Quartz and Terrence J. Sejnowski. The neural basis of cognitive development: A constructivist manifesto. *Behavioral & Brain Sciences*, 20(4):537–596, 1997.
- R. Quillian. Semantic memory. In Marvin Minsky, editor, *Semantic Information Processing*. MIT Press, 1969.
- Paul Quinn, Peter D. Eimas, and Stacey L. Rosenkrantz. Evidence for representations of perceptually similar natural categories by 3-month-old and 4-month-old infants. *Perception*, 22:463–475, 1993.
- Paul C. Quinn. Category representation in young infants. *Current Directions in Psychological Science*, 11(2):66–70, April 2002.
- William Raynor. *The international dictionary of artificial intelligence*. The Genlake Publishing Company, Chicago, 1999.
- E. T. Rolls and A. Treves. *Neural Networks and Brain Function*. Oxford University Press, Oxford, 1997.
- Edmund T. Rolls. Vision, emotion and memory: from neurophysiology to computation. *International Congress Series*, 1250:547–573, 2003.

- Eleanor Rosch. Cognitive representations of semantic categories. *Journal of Experimental Psychology: General*, 104:192–233, 1975a.
- Eleanor Rosch. Family resemblance: Studies in the internal structure of categories. *Cognitive Psychology*, 7:573–605, 1975b.
- Eleanor Rosch. Principles of categorization. In A. Collins and E. E. Smith, editors, *Readings in Cognitive Science: A Perspective from Psychology and Artificial Intelligence*, pages 312–322. Kaufmann, San Mateo, CA, 1988.
- Eleanor Rosch, Carolyn Mervis, Wayne Gray, David Johnson, and Penny Boyes-Braem. Basic objects in natural categories. *Cognitive Psychology*, 8:382–439, 1976.
- F. Rosenblatt. The perceptron: A probabilistic model for information storage and organization in the brain. *Psychological Review*, 65:386–408, 1958.
- F. Rosenblatt. *The Principles of Neurodynamics*. Spartan, New York, 1962.
- Jeffrey N. Rouder, Roger Ratcliff, and Gail McKoon. A neural network model of implicit memory in object recognition. *Psychological Science*, 11:13–19, 2000.
- D. E. Rumelhart, G. E. Hinton, and R. J. Williams. Learning internal representations by error propagation. In *Parallel dis-*

- tributed processing: Explorations in the microstructure of cognition. Vol. 1.* MIT Press, Cambridge, MA, 1986a.
- David E. Rumelhart, James L. McClelland, and the PDP Research Group. *Parallel Distributed Processing: Explorations in the Microstructure of Cognition, Volumes 1 and 2.* MIT Press, Cambridge, 1986b.
- Ulrich Schade. Kochendörfers unbequemes Postulat. Zur Modellierung des Sprachproduktionsprozess. In Dominic Veit und Michael Schecker, editor, „Beschreiben“ und „Erklären“ in der *Klinischen Linguistik*. Gunter Narr Verlag, Tübingen, 2002.
- Ulrich Schade. *Konnektionismus. Zur Modellierung der Sprachproduktion.* Westdeutscher Verlag, Opladen, 1992.
- Ulrich Schade. *Konnektionistische Sprachproduktion.* Deutscher Universitäts-Verlag GmbH, 1999.
- Michael Schmitt. *Automatic Test Generation Based on Formal Specifications.* PhD thesis, Georg-August-Universität, Göttingen, 2003.
- M. Schmutz and W. Banzhaf. Robust competitive networks. *Physical Review*, A 45:4132–4145, 1992.
- Cristoph Schwarze. Lexique et compréhension textuelle. In *Sonderforschungsbereich 99*, number 112. Universität Konstanz, 1985.

- U. Seiffert. Content adaptive compression of images using neural maps. In *Proceedings of the 5th International Workshop on Self-Organizing Maps WSOM 2005*, pages 227–234, Paris, France, 2005.
- S. Shekhar and M. B. Amin. Generalization by neural networks. *IEEE Transactions on Knowledge and Data Engineering*, 4(2): 177–185, 1992. ISSN 1041-4347. doi: <http://dx.doi.org/10.1109/69.134256>.
- Edward E. Smith and Douglas Medin. *Categories and concepts*. Harvard University Press, Cambridge, 1981.
- Paul Smolensky. Connectionist approaches to language. In Rober A. Wilson and Frank C. Keil, editors, *MIT Encyclopedia of the Cognitive Sciences*, pages 188–190. MIT Press, Cambridge, 1999.
- John F. Sowa. *Conceptual Structures: Information Processing in Mind and Machine*. Addison-Wesley, Reading, Mass., 1984.
- John F. Sowa. Semantic networks. In S. C. Shapiro, editor, *Encyclopedia of Artificial Intelligence*. John Wiley & Sons, New York, 1992.
- John. F. Sowa. *Semantic Networks*, 2002. URL <http://jfsowa.com/pubs/semnet.htm>.
- Joseph Stemberger. *The Lexicon in a Model of Language Production*. Garland, New York, 1985.

- Gisela Szagun. *Bedeutungsentwicklung beim Kind. Wie Kinder Wörter entdecken*. Urban & Schwarzenberg, München, 1983.
- Gisela Szagun. *Sprachentwicklung beim Kind*. Psychologie Verlags Union, 6., überarbeitete auflage edition, 1996.
- Alfred Tarski. Pojęcie prawdy w językach nauk dedukcyjnych (=the concept of truth in the languages of the deductive sciences). *Prace Towarzystwa Naukowego Warszawskiego, Wydział III Nauk Matematyczno-Fizycznych*, 34:13–172, 1933.
- John R. Taylor. *Kategoryzacja w języku (= Linguistic categorization. Prototypes in Linguistic Theory)*. Universitas, Kraków, 2001.
- S. Thorpe. Localized versus distributed representations. In M. A. Arbib, editor, *Handbook of Brain Theory and Neural Networks*, page 549?552. MIT Press, Cambridge, MA, 1995.
- R.C. Tryon. *Cluster Analysis*. Edward Brothers, Ann Arbor, MI, 1939.
- A. M. Turing. On computable numbers, with an application to the entscheidungsproblem. *Proceedings of the London Mathematical Society*, 42(2):230–265, 1937.
- Tim van Gelder. Distributed vs. local representation. In Rober A. Wilson and Frank C. Keil, editors, *MIT Encyclopedia of the Cognitive Sciences*, pages 236–238. MIT Press, Cambridge, 1999.

- P. Vermersch. Introspection as practice. *Journal of Consciousness Studies*, 6:17–42, 1999.
- J. Wannemacher and M. Ryan. “less” is not “more”: a study of children’s comprehension of “less” in various task contexts. *Child Development*, 49:660–668, 1978.
- Alan R. White. Conceptual analysis. In C. J. Bontempo and S. J. Odell, editors, *The Owl of Minerva*, pages 103–117. McGraw-Hill, New York, 1975.
- Benjamin Whorf. *Language, Thought, and Reality: Selected Writings*. MIT Press, Boston, MA, 1956.
- Anna Wierzbicka. *Lexicography and conceptual analysis*. Karoma, Ann Arbor, 1985.
- Ludwig Wittgenstein. *Philosophische Untersuchungen*. Suhrkamp, Frankfurt am Main, 1971.
- W.A. Woods and J.G. Schmolze. The KL-ONE family. *Computers Math. Applic.*, 23(2):133–177, 1992.
- William A. Woods. What’s in a link: foundations for semantic networks. In D. G. Bobrow and A. Collins, editors, *Representation and Understanding*, pages 35–82. Academic Press, New York, 1975.
- Wilhelm Max Wundt. *Grundzüge der physiologischen Psychologie*. Wilhelm Engelmann, Leipzig, 1874.

- Wilhelm Max Wundt. *Outlines of Psychology*. Wilhelm Engelmann, Leipzig, 1897.
- Wilhelm Max Wundt. *Principles of Physiological Psychology*. The MacMillan CO, New York, 1904.
- Lofti Zadeh. Calculus of fuzzy restrictions. In L.A.Zadeh, K.-S. Fu, K. Tanaka, and M. Shimura, editors, *Fuzzy Sets and Their Applications to Cognitive and Decision Processes*. Academic Press, New York, 1975.
- Lofti Zadeh. Fuzzy sets. *Journal of Information and Control*, 8: 338–353, 1965.

List of Citations

- Amerijckx et al. (2003), 82
Anderson and Bower (1973), 98
Anderson and Durand (1986), 35,
36
Anderson and Mozer (1989), 82
Anderson (1972), 67
Anderson (1983), 98
Anderson (1992), 35
Aristotle (1908), 32
Aristotle (1928), 22, 23, 32, 93
Ashby and Maddox (2005), 60
Barsalou (1992), 58
Berg and Schade (1992), 89
Berg (1988), 87
Berlin (1992), 46, 47
Bobrow (1969), 67
Brachman and Schmolze (1985), 101,
102
Brachman et al. (1990), 94
Brachman (1979), 99
Brooks (1978), 57
Broomhead and Lowe (1988), 110
Carey (1982), 38
Carpenter and Grossberg (1991),
82
Ceccato (1961), 96
Chomsky and Halle (1968), 33, 34
Christiansen and Chater (1994), 154
Clark (1973), 37
Clements and Hume (1995), 34
Collins and Loftus (1975), 97, 99
Collins and Quillian (1969), 97, 98
Cruse (1977), 48
Daniloff and Hammarberg (1973),
35
Dell et al. (1997), 88

- Dell (1986), 67, 73, 86, 87, 184
Dienes (1992), 81
Dixon (1982), 55
Ellis and Humphreys (1999), 76,
126, 177
Elman (1990), 80
Evans (1969), 67
Fillmore (1982), 56
French (1999), 85, 187
Fromkin (1971), 88
Gadenne (1998), 139
Gall and Spurzheim (1809/1967),
70
Gansner et al. (2006), 133, 135
Garrett (1975), 88
Ge and Iwata (2002), 153
Geeraerts (1986), 49
Geeraerts (1988), 52, 53, 56
Ghosh and Pal (1992), 82
Gipper (1972), 31
Goldstone (1998), 179
Grainger and Jacobs (1998), 65,
86, 186
GraphViz Website (2007), 133, 134
Graubard (1988), 68
Grossberg (1976), 67
Hampton (1999), 90
Harnad (2003), 58
Hebb (1949), 124
Hinton and Sejnowski (1999), 81
Hurford and Heasley (2004), 45
JBuilder (2007), 135
Jacoby (1983), 182
Jain et al. (1999), 84
Java Website (2007), 132
Jordan (1986), 80
Jordan (1995), 110
Kant (1787/1990), 23, 24
Kavanaugh (1976), 38
Kempen and Huijbers (1983), 88
Kingsland (1995), 75
Kleiber (2003), 36, 47, 54, 59
Koch et al. (1982), 103, 111
Koch et al. (1983), 103, 111
Kohonen (1972), 67
Kohonen (1982), 81, 110, 124, 184
Krebs (2005), 104
Kruschke (1992), 81, 187
Labov (1974), 30, 40, 138, 160–
162, 165, 168, 181
Ladefoged (1975), 34
Lagus et al. (1999), 82
Lakoff (1973), 40
Lakoff (1986), 55
Lakoff (1987), 29, 36, 48, 49, 53,
56
Laver (1994), 34
Lawrence et al. (2000), 80
Levelt et al. (1999), 88
Levelt (1989), 88, 183
Lieberman (1992), 123
Liggesmeyer (2002), 138

- Lindau (1978), 34
Lubker (1981), 35
MacWhinney (2000), 183
Mareschal and French (2000), 176
Mareschal et al. (2000), 139, 170,
176, 185, 187
Masterman (1962), 96
McClelland and Elman (1986), 67,
73
McClelland and Rumelhart (1981),
67, 110
McClelland and Rumelhart (1985),
81
McCullagh and Nelder (1989), 110
McCulloch and Pitts (1943), 65
McLeod et al. (1998), 73, 76, 178
Medin and Schaffer (1978), 57
Medler (1998), 63
Mel (1994), 103, 111
Merkl (1998), 82
Miikkulainen (1990), 184
Milnor (1985), 116
Minsky and Papert (1969), 66, 80
Moody and Darken (1989), 110
Musavi et al. (1994), 154
Ogden and Richards (1923), 90
Osherson and Smith (1981), 50, 51
Otto (2002), 68
Page (2000), 72, 189
Parker (1985), 78
Petrus Hispanicus (ca. 1239/1947),
94
Pettijohn (1998), 127
Plaut and Botvinick (2004), 187
Popper (1935/1994), 138
Porphyry (1994), 93
Quartz and Sejnowski (1997), 125,
187
Quillian (1969), 67
Quinn et al. (1993), 61, 169, 170,
176, 184
Quinn (2002), 139, 184
Raynor (1999), 127, 180
Rolls and Treves (1997), 153
Rolls (2003), 153
Rosch et al. (1976), 26, 47, 48, 58
Rosch (1975a), 40, 43, 44
Rosch (1975b), 40, 51, 181
Rosch (1988), 40, 41, 44, 48, 121
Rosenblatt (1958), 66, 77
Rosenblatt (1962), 66
Rouder et al. (2000), 187
Rumelhart et al. (1986a), 78, 79
Rumelhart et al. (1986b), 67, 77,
125, 187
Schade (1992), 89
Schade (1999), 73, 89
Schade (2002), 189
Schmitt (2003), 138
Schmutz and Banzhaf (1992), 110
Schwarze (1985), 45

- Seiffert (2005), 82
Shekhar and Amin (1992), 154
Smith and Medin (1981), 30
Smolensky (1999), 105
Sowa (1984), 90
Sowa (1992), 92
Sowa (2002), 95, 124
Stemberger (1985), 184
Szagun (1983), 38
Szagun (1996), 37
Tarski (1933), 68
Taylor (2001), 30, 44
Thorpe (1995), 72
Tryon (1939), 81
Turing (1937), 65
Vermersch (1999), 128
Wannemacher and Ryan (1978), 38
White (1975), 92
Whorf (1956), 31
Wierzbicka (1985), 44, 50
Wittgenstein (1971), 38, 40, 53, 54,
180
Woods and Schmolze (1992), 94
Woods (1975), 99
Wundt (1874), 128
Wundt (1897), 128
Wundt (1904), 128
Zadeh (1965), 51
Zadeh (1975), 51
le Cun (1985), 78
van Gelder (1999), 71

Implementation of the Central Algorithm Parts

The algorithm presented in chapter 4, page 109 was implemented in Java programming language (version 1.4.2). The following snippets illustrate the implementation of central elements, namely, calculating the activation spreading.

A.1 Activation from Parent Nodes

The method `getTopDownExcitation` calculates the activation coming from parent nodes (formula 4.3, page 119).

```
1 protected double getTopDownExcitation( int iNode )
2 {
3     int i;
4     int iCnt = 0;
5     double dEx;
```

```

6
7 // calculate "distance"
8 dEx = 0.0;
9 for( i = 0; i < size; i++ )
10 {
11     if( i == iNode || excitation[i][iNode] < dEpsilon )
12         continue;
13
14     iCnt++;
15     dEx += (excitation[i][iNode] - nodes[i].activation)*
16             (excitation[i ][iNode] - nodes[i].activation);
17 }
18 if( iCnt == 0 ) // no input at all!
19     return 0.0;
20
21 // calculate gaussian
22 dEx = Math.exp( - dEx / (2.0*dGaussR2 ) );
23 return dEx;
24 }

```

A.2 Activation from Child Nodes

The following method `getBottomUpExcitation` calculates the activation coming from child nodes (formula 4.4, page 120).

```

1 protected double getBottomUpExcitation( int iNode )
2 {
3     int k, iCnt;
4     double dEx;
5
6     // calculate activation
7     dEx = 0.0;
8     iCnt = 0;
9     for( k = 0; k < size; k++ )
10    {
11        if( iNode == k || nodes[k].activation < 0.95 )
12            continue;
13        if( excitation[iNode][k] < dEpsilon )
14            continue;
15
16        dEx += excitation[iNode][k] * nodes[k].activation;
17        iCnt++;
18    }
19 }

```

```

20  if( iCnt != 0 )
21      dEx /= iCnt;
22
23  return dEx;
24  }

```

A.3 Final Activation

The final activation, calculated according to the formula 4.7 (page 121), was implemented in the following way. The first snippet contains the inhibition calculation according to formula 4.6.

```

1
2  dInh = 0.0;
3  for( k = 0; k < size; k++ )
4      if( k != j )
5          dInh += inhibition[k][j] * nodes[k].activation;

```

The values obtained from the above calculations are used as parameters for the overloaded method `activationFunction(double, double, double, double)` (lines 1-14). The other version of this method `activationFunction(double, double)` (line 16 on) calculates the change of the activation value in time.

```

1  protected double activationFunction( double dTD, double dBU,
      double dInh, double dPrevAct )
2  {
3      double d2;
4
5      d2 = activationFunction( dTD, dPrevAct );
6      d2 = Math.max( dBU, d2 ) - dInh;
7      d2 = Math.max( 0.0, d2 );
8      d2 = Math.min( d2, 1.0 );
9
10     if( dPrevAct > d2 && d2 < dEpsilon )
11         return 0.0;
12
13     return d2;
14 }
15

```

```
16 protected double activationFunction( double dIn, double
    dPrevAct )
17 {
18     double dOut;
19
20     if ( dIn > 0.0 ) // choose between two possible cases
21         dOut = dPrevAct * ( 1.0 - activationDecay ) + dIn * (
            1.0 - dPrevAct );
22     else
23         dOut = dPrevAct * ( 1.0 - activationDecay ) + dIn *
            dPrevAct;
24
25     return dOut;
26 }
```

Example *dot* description of a network

The following listing shows parts of the *dot* description of one of the example networks used in the autoassociation experiment (see figure 6.6b, page 152).

```
1 digraph {
2   node [style=filled]
3
4   { rank = source; armour selfprop tank tracked antitank hot
5     tow howitzer towed };
6   { rank = same; FH_70 };
7   { rank = same; LEOPARD_2 PzH2000 "antitank\narmour\nselfprop
8     \ntracked\n" };
9   { rank = same; JAGUAR_1 JAGUAR_2 };
9   armour [fillcolor=gray100 fontcolor=black];
10  selfprop [fillcolor=gray100 fontcolor=black];
11  tank [fillcolor=gray100 fontcolor=black];
12  tracked [fillcolor=gray100 fontcolor=black];
13  "armour\nselfprop\ntank\ntracked\n" [fillcolor=gray100
14    fontcolor=black];
```

```

14 LEOPARD_2 [fillcolor=gray100 fontcolor=black];
15 antitank [fillcolor=gray100 fontcolor=black];
16 hot [fillcolor=gray100 fontcolor=black];
17 "antitank\narmour\nhot\nselfprop\ntracked\n" [fillcolor=
    gray100 fontcolor=black];
18 JAGUAR_1 [fillcolor=gray100 fontcolor=black];
19 tow [fillcolor=gray100 fontcolor=black];
20 "antitank\narmour\nselfprop\ntow\ntracked\n" [fillcolor=
    gray100 fontcolor=black];
21 JAGUAR_2 [fillcolor=gray100 fontcolor=black];
22 howitzer [fillcolor=gray100 fontcolor=black];
23 towed [fillcolor=gray100 fontcolor=black];
24 "howitzer\ntowed\n" [fillcolor=gray100 fontcolor=black];
25 FH_70 [fillcolor=gray100 fontcolor=black];
26 "armour\nhowitzer\nselfprop\ntracked\n" [fillcolor=gray100
    fontcolor=black];
27 PzH2000 [fillcolor=gray100 fontcolor=black];
28 "armour\nselfprop\ntracked\n" [fillcolor=gray100 fontcolor=
    black];
29 "antitank\narmour\nselfprop\ntracked\n" [fillcolor=gray100
    fontcolor=black];
30 edge [color=black] armour -> "armour\nselfprop\ntracked\n";
31 edge [color=black] selfprop -> "armour\nselfprop\ntracked\n"
    ;
32 edge [color=black] tank -> "armour\nselfprop\ntank\ntracked\
    n";
33 "armour\nselfprop\ntank\ntracked\n" -> LEOPARD_2;
34 edge [color=black] tracked -> "armour\nselfprop\ntracked\n";
35 edge [color=black] antitank -> "antitank\narmour\nselfprop\
    ntracked\n";
36 edge [color=black] hot -> "antitank\narmour\nhot\nselfprop\
    ntracked\n";
37 "antitank\narmour\nhot\nselfprop\ntracked\n" -> JAGUAR_1;
38 edge [color=black] tow -> "antitank\narmour\nselfprop\ntow\
    ntracked\n";
39 "antitank\narmour\nselfprop\ntow\ntracked\n" -> JAGUAR_2;
40 edge [color=black] howitzer -> "howitzer\ntowed\n";
41 "howitzer\ntowed\n" -> FH_70;
42 edge [color=black] howitzer -> "armour\nhowitzer\nselfprop\
    ntracked\n";
43 "armour\nhowitzer\nselfprop\ntracked\n" -> PzH2000;
44 edge [color=black] towed -> "howitzer\ntowed\n";
45 edge [color=black] "armour\nselfprop\ntracked\n" -> "armour\
    nselfprop\ntank\ntracked\n";
46 edge [color=black] "armour\nselfprop\ntracked\n" -> "armour\
    nhowitzer\nselfprop\ntracked\n";
47 edge [color=black] "armour\nselfprop\ntracked\n" -> "
    antitank\narmour\nselfprop\ntracked\n";

```

```
48 edge [color=black] "antitank\narmour\nselfprop\ntracked\n"  
   -> "antitank\narmour\nhot\nselfprop\ntracked\n";  
49 edge [color=black] "antitank\narmour\nselfprop\ntracked\n"  
   -> "antitank\narmour\nselfprop\ntow\ntracked\n";  
50 }
```