

Teichmüller curves in the Deligne-Mumford compactification

Dissertation

zur

Erlangung des Doktorgrades (Dr. rer. nat.)

der

Mathematisch-Naturwissenschaftlichen Fakultät

der

Rheinischen Friedrich-Wilhelms-Universität Bonn

vorgelegt von

Igor Ronkin

aus

Charkiw

Bonn 2008

Angefertigt mit der Genehmigung der Mathematisch-Naturwissenschaftlichen
Fakultät der Rheinischen Friedrich-Wilhelms-Universität Bonn

1. Referent: Prof. Dr. Ursula Hamenstädt
2. Referent: Prof. Dr. Werner Ballmann

Tag der Promotion: 14. November 2008

Diese Dissertation ist auf dem Hochschulschriftenserver der ULB Bonn unter
http://hss.ulb.uni-bonn.de/diss_online elektronisch publiziert.

Erscheinungsjahr 2008

Contents

0	Introduction	1
1	Moduli spaces as orbifolds	3
1.1	Orbifolds	4
1.2	Moduli spaces	6
2	Flat and translation surfaces	11
3	Teichmüller discs and curves	14
3.1	Teichmüller discs	14
3.2	Properties of Teichmüller discs	16
3.3	Teichmüller curves	18
3.4	Abelian Teichmüller curves	20
3.5	Examples	20
4	Cusps of Teichmüller curves	24
5	Universal curve over a cusp	26
5.1	Surface bundle over a disc	26
5.2	The fibers of the surface bundle	28
5.3	Intersection with the compactification divisor	30
5.4	Examples	32
6	Evaluation of κ_1 on abelian Teichmüller curves	35
6.1	Holomorphic section in \mathcal{B} and its zeros	35
6.2	Holomorphic section in the cotangent bundle of the universal curve	36
6.3	Evaluation of κ_1 on \overline{V} and on \overline{C}	37
6.4	Weil-Petersson vs. Teichmüller area	39
6.5	Examples	40

0 Introduction

The central point of most studies of Riemann surfaces is the Uniformization Theorem, the mighty black box that brings the conformal and hyperbolic structures in one-to-one correspondence. On the one hand, we profit from the variety of points of view for surfaces: to the two viewpoints mentioned above we can add the complex and the algebraic ones; thus we obtain a lot of tools coming from different areas of mathematics. On the other hand, passing from one structure to another is quite often a hard task, which makes the use of different tools at the same time rather difficult.

For instance, assume a Riemann surface given by some equations in $\mathbb{C}\mathbb{P}^n$. Then we can work with its complex and algebraic structures fairly explicitly. What about the hyperbolic structure? Can we compute the length spectrum? Or just the length of the shortest closed curve? If the algebraic structure is a special one, e.g. has a lot of automorphisms, then we have a chance to determine the hyperbolic structure. In general, however, we can only hope to obtain good estimates, using fact like this: If a complex cylinder of small modulus can be imbedded in the surface, then the core curve of the imbedding's image is short.

When passing from a single Riemann surface to bundles of Riemann surfaces, i.e. studying the moduli space \mathcal{M}_g , the problems get even worse. Namely, we have to understand how a *change* of one structure affects the others. For instance, moving along a Teichmüller geodesic is, in a sense, a well understood change of a complex structure, which is hard to describe in hyperbolic (Fenchel-Nielsen coordinates) or algebraic terms.

For the study of the moduli space, many different structures on it have been introduced, all being natural in the sense of being defined in terms of structures on Riemann surfaces. As a consequence, each of these natural structures on \mathcal{M}_g can be used to study (bundles of) Riemann surfaces from one or two viewpoints mentioned in the beginning; however, non of the structures on \mathcal{M}_g is well adapted to all four viewpoints.

The problem of passing between the structures lifts from structures on Riemann surfaces to those on \mathcal{M}_g , though some links exist. For instance, the Deligne-Mumford compactification $\overline{\mathcal{M}}_g$, which allows to study the algebraic orbifold structure on \mathcal{M}_g , is hard to interpret in terms of the Teichmüller metric, but is just the completion with respect to the Weil-Petersson metric. Another example is the fact that the Kobayashi metric with respect to the complex structure on \mathcal{M}_g coincides with the Teichmüller metric.

On the other hand, there are very special subspaces of \mathcal{M}_g which are, in analogy to Riemann surfaces with many automorphisms, well-behaved to most of the many structures on \mathcal{M}_g . These so called Teichmüller curves are holomorphic immersions of complex curves (Riemann surfaces of finite type) in \mathcal{M}_g , which are isometric with respect to the Teichmüller metric. Alternatively, they are constructed as projections of closed orbits of a natural $\mathrm{GL}_2^+ \mathbb{R}$ -action on the moduli

space's cotangent bundle.

In this thesis, we study how Teichmüller curves lie in the compactification $\overline{\mathcal{M}}_g$, and, although we are not able to compare the restrictions of Teichmüller and Weil-Petersson metrics locally, we compare the areas of abelian Teichmüller curves with respect to those metrics. More precisely, we study the homology class of Teichmüller curves in $H_2(\overline{\mathcal{M}}_g, \mathbb{Q})$ by evaluating the following cohomology classes on them:

- The class of the compactification divisor $\mathcal{D} = \overline{\mathcal{M}}_g \setminus \mathcal{M}_g$ is evaluated by computing the intersection number of a compactified Teichmüller curve with \mathcal{D} . In the somewhat special case of abelian Teichmüller curves we deduce the intersection number with each component of \mathcal{D} .
- For abelian Teichmüller curves, we evaluate the first Morita-Mumford cohomology class κ_1 on the homology class of Teichmüller curve. Since the components of \mathcal{D} and κ_1 generate $H^2(\overline{\mathcal{M}}_g, \mathbb{Q})$ freely, this evaluation completes the homological study of abelian Teichmüller curves.

By Wolpert's results, κ_1 is a multiple of the cohomology class of the Weil-Petersson Kähler form. Since a Teichmüller curve is holomorphically immersed, the evaluation of κ_1 provides a computation of the Weil-Petersson area of an abelian Teichmüller curve. Since Teichmüller curves are isometrically immersed with respect to Teichmüller metric, we can easily compute this area too. Comparing the two areas, we see that the quotient of both depends on surprisingly few data.

This thesis is organized as follows. In the first section we introduce orbifolds, and define moduli spaces as well as related structures. A reader familiar with these can as well skip this section. Note however, that we take the strong notion of orbifolds, allowing isotropy groups to act trivially. In the next section we introduce flat surfaces, a notion closely related to that of holomorphic quadratic differentials. In the third section we define an action of $\mathrm{PSL}_2 \mathbb{R}$ on the space of flat surfaces, and relate this to the action of $\mathrm{PSL}_2 \mathbb{R}$ by Möbius transformations on the lower half-plane $\overline{\mathbb{H}}$. Out of this relation we obtain a map $\overline{\mathbb{H}} \rightarrow \mathcal{T}_g$ into the Teichmüller space, which we call Teichmüller disc, and show this to be a holomorphic and isometric imbedding. We define Teichmüller curves to be *closed* images of Teichmüller discs in \mathcal{M}_g , which is a very restrictive condition.

Note that our definition of Teichmüller curves as *suborbifolds* of \mathcal{M}_g differs slightly from the usual one, which we discuss in the remark at the end of Section 5 and in Section 6.4. Our definition takes note of the *trivial* action of automorphisms of flat surfaces on Teichmüller curves; as we are working with the strong notion of orbifolds, this definition is quite natural.

In Section 4 we prepare passing to $\overline{\mathcal{M}}_g$ by considering the cusps of a Teichmüller curve. So far, we introduced a setting known to mathematicians working

in Teichmüller theory. At least since Veech's papers in the 80s, where he found a relation to the dynamics of billiards, this setting has been an object of many studies. On the contrary, Sections 5 and 6 contain new constructions and results.

In Section 5, the main idea is to adapt the usual procedure of opening-up-nodes of a noded surface to the context of *flat* surfaces. We construct a bundle of flat surfaces over a disc D such that

- the complex structures of all but one fibers correspond to points in the image of Teichmüller curve's cusp,
- in suitable coordinates of $\overline{\mathcal{M}}_g$, where the divisor is given by a simple function, the classifying map $D \rightarrow \overline{\mathcal{M}}_g$ can easily be made precise.

Using these properties we are able to compute the intersection number of the compactified cusp and the compactification divisor \mathcal{D} .

In the last section, we use the previous construction to compute the zero divisor of a holomorphic section in the relative cotangent bundle of the universal curve over an *abelian* Teichmüller curve. This leads us to the evaluation of the first Morita-Mumford class on the homology class of the Teichmüller curve.

Acknowledgements. I am deeply indebted to Professor Ursula Hamenstädt, who introduced me to this field and supported me steadily, especially in bad times. Her patience and many fruitful discussions with her made this thesis possible. I also thank Thomas Foertsch, Benjamin Ko, Alexander Lytchak, Emanuel Nipper, Juan Souto and Sewa Shevchishin for various conversations and much more, and Heike Bacher for the good mood inside the working group. I am grateful for the financial support that I received from Max-Planck-Institute in Bonn during the most time of my doctoral studies. My personal thanks for the moral support go to my parents and to my wife Natalie. Finally, special thanks go to Dr. Armin Holschbach for careful proofreading and language editing.

1 Moduli spaces as orbifolds

The natural environments of the objects of this work are the moduli spaces, which we introduce in this section. There are many different ways to handle these spaces; for this thesis the orbifold viewpoint is appropriate. We use the strong notion of orbifolds, allowing isotropy groups to act trivial. In the first subsection we give the definition of orbifolds, state some properties, and define the essential objects on orbifolds, such as vector bundles, divisors, Chern classes etc. In the second we define Teichmüller and moduli spaces and describe the Deligne-Mumford compactification. After that we introduce the universal curve, its relative tangent bundle, the compactification divisor, and the Mumford-Morita classes.

1.1 Orbifolds

Let X be a topological space. A *chart* or *coordinate neighborhood* for X is a triple $(\tilde{U}, \Gamma, \phi)$, where $\tilde{U} \subset \mathbb{C}^n$ is open, Γ is a finite group acting by biholomorphisms on \tilde{U} , $\phi : \tilde{U} \rightarrow U \subset X$ is a continuous map onto an open subset of X , such that $\phi \circ \gamma = \phi$ for all $\gamma \in \Gamma$ and ϕ induces a homeomorphism $\tilde{U}/\Gamma \rightarrow U$.

A collection of charts defines an *orbifold structure* on X if the collection $(U_i)_i$ is a base for the topology of X and the following compatibility condition is satisfied: whenever $U_1 \subset U_2$, there exists a holomorphic imbedding $\lambda : \tilde{U}_1 \rightarrow \tilde{U}_2$ and an injective group homomorphism $\lambda_\Gamma : \Gamma_1 \rightarrow \Gamma_2$ such that $\phi_1 = \phi_2 \circ \lambda$ and $\lambda \circ \gamma = \lambda_\Gamma(\gamma) \circ \lambda$ for any $\gamma \in \Gamma_1$.

If $0 \in \tilde{U}$ and Γ fixes 0 , we call \tilde{U} a coordinate neighborhood for $\phi(0)$, and refer to Γ as the *isotropy group* of $\phi(0)$, which is well-defined up to isomorphy.

A *manifold* is an orbifold with trivial isotropy groups.

An *orbifold morphism* is a continuous map $f : X \rightarrow Y$ together with injections of isotropy groups $\Gamma_x \rightarrow \Gamma_{f(x)}$ such that for any $x \in X$ there exists a holomorphic lift $\tilde{f} : \tilde{U}_x \rightarrow \tilde{U}_{f(x)}$ compatible with isotropy groups and projections. An orbifold morphism is a *cover* if the local lifts can be chosen biholomorphic.

Let X be an orbifold and let G act properly discontinuously by morphisms on X . Then the *quotient* orbifold X/G is defined in the usual way, using the charts of X . We call the projection $X \rightarrow X/G$ a *normal cover* with *covering group* G ; the order of G is the *degree* of the normal cover.

A *good orbifold* is an orbifold X that admits a finite normal manifold cover, i.e. there exists a manifold \tilde{X} and a finite group G acting on \tilde{X} such that $\tilde{X}/G \cong X$. A finite normal manifold cover exists whenever some finite manifold cover exists. We will be dealing with good orbifolds only.

Remark. The homomorphism $\Gamma \rightarrow \text{Aut}(\tilde{U})$ does not have to be injective. If X is connected, the kernels of these morphisms are isomorphic for all charts. Let $\tilde{X} \rightarrow X$ be a normal manifold cover with the covering group G , i.e. we have a homomorphism $G \rightarrow \text{Aut}(\tilde{X})$. Then the kernel of the map is a subgroup of the isotropy group of any point in M .

In the category of orbifold, *fiber products* exist, i.e. given morphisms $Y \xrightarrow{f_1} X$ and $Z \xrightarrow{f_2} X$, there exists a unique orbifold $Y \times_X Z$ and morphisms $Y \times_X Z \xrightarrow{p_1} Y$ and $Y \times_X Z \xrightarrow{p_2} Z$ satisfying $f_1 \circ p_1 = f_2 \circ p_2$ with the following property: given an orbifold T , and morphisms $T \xrightarrow{t_1} Y$ and $T \xrightarrow{t_2} Z$ with $f_1 \circ t_1 = f_2 \circ t_2$, there exists a unique $T \xrightarrow{t} Y \times_X Z$ with $p_i \circ t = t_i$, for $i = 1, 2$.

If $Y \rightarrow X$ is a normal cover, so is $Y \times_X Z \rightarrow Z$, with the same covering group. Since an orbifold morphism induces an injection of isotropy groups, $Y \times_X Z$ is a manifold if Y is one. Sometimes we refer to $Y \times_X Z \rightarrow Z$ as the *preimage* of $Y \rightarrow X$ under $Z \rightarrow X$ ¹.

¹In the category of sets or manifolds, for an inclusion $Y \rightarrow X$, the map $Y \times_X Z \rightarrow Z$ is indeed the inclusion of the preimage.

In the following we extend some concepts from the category of manifolds to orbifolds. For manifolds we can use the usual definitions.

Local objects, like differential forms, can be defined in terms of charts, and then get patched together to global objects. For instance, we define a *differential form* locally to be a differential form on a chart \tilde{U} , invariant under the isotropy group. The usual transition condition then gives us the notion of global differential form. In the same manner we can define *divisors* and *vector bundles*. Note that the definition of vector bundles does not coincide with the usual one when the orbifold is viewed as the underlying topological space. For instance, we define orbifold tangent and cotangent bundles to be locally tangent and cotangent bundles of chart neighborhoods with the usual identifications via derivative and coderivative of transition maps and isotropy groups. By this definition, the fiber over a point is a quotient of a vector space by the isotropy group. In order to save the intuition of local triviality, we can regard the tangent space at a point as a vector space equipped with an action of the isotropy group. This can be achieved by generalizing the notion of points to geometric points, however we do not go into these details.

In the case of good orbifolds we can define the global objects directly, by taking the corresponding objects on any normal manifold cover, which are invariant under the covering group. Then a *vector bundle* is a vector bundle on some manifold cover, equipped with a lift of the covering group's action to bundle automorphisms. Analogously we can define other *bundles*; we will use the notion of *surface bundles*.

The set of complex line bundles over an orbifold X endowed with the tensor product is a group which we call $\text{Pic}(X)$. Again, this is not the classical Picard group of the underlying topological space. Usually this one is called the *orbifold Picard group*, but since we have no use for the classical one we omit the “orbifold” in our notation.

Let $Y \xrightarrow{p} X$ be a finite normal manifold cover, let G be the covering group. Then the pullback $p^* : H^*(X, \mathbb{Q}) \rightarrow H^*(Y, \mathbb{Q})$ is injective and the image of p^* consists of the G -invariant elements in $H^*(Y, \mathbb{Q})$.² Hence, we can define a push forward $p_! : H^*(Y, \mathbb{Q}) \rightarrow H^*(X, \mathbb{Q})$ by the property $|G|p^*p_!(\alpha) = \sum_{g \in G} g^*\alpha$. Note that for a G -invariant $\alpha \in H^*(Y, \mathbb{Q})$ we obtain $p^*p_!(\alpha) = \alpha$. For instance, given a line bundle in $\text{Pic}(X)$, we can pass to a manifold cover Y , construct the first Chern class of the pulled back bundle and push forward the obtained element from $H^2(Y, \mathbb{Q})$ to $H^2(X, \mathbb{Q})$. We call the resulting cohomology class, which does not depend on the choice of Y , the *Chern class* of the line bundle. The constructed assignment $\text{Pic}(X) \rightarrow H^*(X, \mathbb{Q})$ is a homomorphism of groups.

The *fundamental class* $[X] \in H_{2\dim_{\mathbb{C}}X}(X, \mathbb{Q})$ is defined as $\frac{1}{|G|}p_*([Y])$. This definition is also independent of the choice of Y .

²By homology and cohomology of an orbifold we mean the usual homology and cohomology of the underlying topological space.

Since we can define *characteristic classes* not only for line bundles but more generally for vector bundles, we are able to define the (*orbifold*) *Euler characteristic* $\chi(X)$ of a good orbifold X , as the evaluation of the tangent bundle's Euler class e_X on the fundamental class $[X]$. Since $\pi^*e_X = e_Y$, we conclude $|G|\chi(X) = \chi(Y)$. Note that in general $\chi(X)$ is rational but not an integer.

Remark Let X be an orbifold, G a finite group. Let G act trivially on X . Then $X/G \not\cong X$ as orbifolds, for instance $|G|\chi(X/G) = \chi(X)$.

1.2 Moduli spaces

Teichmüller space. Let $g > 1$ be an integer. Fix a closed topological surface S of genus g . Consider the set of pairs (X, f) , where X is a Riemann surface and f is a homeomorphism $S \rightarrow X$, which we call a marking. By a Riemann surface we mean a conformal, complex or hyperbolic structure on the underlying topological space; by the uniformization theorem these data are equivalent. We define the pairs (X_1, f_1) and (X_2, f_2) to be equivalent, if there exists a conformal (biholomorphic, isometric) map $X_1 \rightarrow X_2$ that is homotopic to $f_2 \circ f_1^{-1}$. The Teichmüller space $\mathcal{T}(S)$ of S is the set of equivalence classes of this relation. The base surface S plays no essential role, since any change of the base by a homeomorphism gives rise to a bijection of Teichmüller spaces. In the following we use the notation \mathcal{T}_g .

Teichmüller metric. For the equivalence classes of pairs (S_1, f_1) and (S_2, f_2) as above, we define their Teichmüller distance to be $\frac{1}{2} \inf_f \log(K_f)$, where K_f is the quasiconformal constant of f , and f varies over diffeomorphisms homotopic to $S_1 \xrightarrow{f_2 \circ f_1^{-1}} S_2$. With the topology induced by this metric, \mathcal{T}_g is homeomorphic to an open real $(6g - 6)$ -dimensional ball.

Complex structure. For a fixed point in \mathcal{T}_g , Bers constructed a local imbedding of \mathcal{T}_g into a complex vector space dual to the space of holomorphic quadratic differentials on the corresponding fixed surface. After the verification of the compatibility of this construction with a change of the base one defines the complex structure by requiring the imbedding to be holomorphic. The cotangent bundle of \mathcal{T}_g can then be identified with the bundle of pairs (X, ω) , where X is a marked Riemann surface and ω is a holomorphic quadratic differential on X . We denote this bundle by $\Omega^2\mathcal{T}_g$.

Royden showed that the Kobayashi metric with respect to this complex structure coincides with the Teichmüller metric.

Weil-Petersson metric. Using the identification mentioned above, one defines a Riemannian metric on the cotangent bundle of \mathcal{T}_g by $\langle \phi, \psi \rangle_{WP} := \int_{X_p} \frac{\overline{\phi}\psi}{\rho^2}$ on $T_p^*\mathcal{T}_g$, where p is a point in \mathcal{T}_g , X_p is the corresponding Riemann surface, ϕ and ψ are quadratic differentials on X_p and ρ is the hyperbolic metric on X . By duality we obtain a metric on \mathcal{T}_g , which is called Weil-Petersson metric. This metric turns out to be non-complete, CAT(0) and Kähler. We denote the Kähler

form by ω_{WP} .

Map_g action. Given an orientation-preserving homeomorphism of the base surface S , we can precompose its inverse to the marking $S \xrightarrow{f} X$ and obtain a new marking on X . Since the homeomorphisms homotopic to identity act trivially, we have defined an action of the group $\text{Map}(S)$ of homotopy classes of orientation preserving homeomorphisms of S on $\mathcal{T}(S)$, and, as above, an action of Map_g on \mathcal{T}_g . This action is properly discontinuous and preserves all the three structures. Hence we can push forward the distance functions to the quotient space.

The stabilizers of points in \mathcal{T}_g are easily seen to be canonically isomorphic to the groups of conformal self-maps (biholomorphic self-maps, hyperbolic isometries) of corresponding Riemann surfaces.

Moduli space. The moduli space $\mathcal{M}_g = \mathcal{T}_g / \text{Map}_g$ is the set of Riemann surfaces up to conformal (biholomorphic, isometric) equivalence, since the markings do not matter for the quotient. Since the action is not free, \mathcal{M}_g does not inherit a manifold structure from \mathcal{T}_g , instead we can define a complex orbifold structure induced by the manifold structure on \mathcal{T}_g .

Orbifold structure on \mathcal{M}_g . We define the orbifold structure on $\mathcal{M}_g = \mathcal{T}_g / \text{Map}_g$ by taking small balls in \mathcal{T}_g as coordinates. Note that $\text{Map}(S)$ acts on any homology group of S . Take the quotient of \mathcal{T}_g by the kernel of $\text{Map}(S) \rightarrow \text{Aut}(H_1(S, \mathbb{Z}/n))$ for any $n > 2$, which acts freely on \mathcal{T}_g . This quotient is then a manifold that covers \mathcal{M}_g normally of finite degree.

Compactification of \mathcal{M}_g . The moduli space \mathcal{M}_g is non-compact, for instance the continuous function assigning to each Riemann surface the length of the shortest geodesic in the hyperbolic structure does not attain its infimum. However, there is a natural compactification $\overline{\mathcal{M}}_g$ due to Mumford and Deligne. The additional points in $\overline{\mathcal{M}}_g$ correspond to Riemann surfaces with pinched curves; so called noded surfaces:

A *noded surface* is a complex space such that each point has either a neighborhood biholomorphic to a disc or to a neighborhood of 0 in the variety defined by $xy = 0$ in \mathbb{C}^2 . A *node*, in this definition, is a point of second type. From the hyperbolic point of view, we allow cusps which are ordered pairwise; a node is such a pair of cusps.

We can extend the orbifold structure of \mathcal{M}_g to the compactification by defining chart neighborhoods for the new points. For this purpose we need to know how to open up the nodes, i.e. to pass smoothly from noded surfaces to the usual ones.

Opening up nodes (after [Wo85]). Let X_0 be a noded surface with nodes x_1, \dots, x_k . For each node we choose D_i^+ and D_i^- disjointly, a pair of discs intersecting in the node x_i . Choose coordinates: $z_i^- : D \rightarrow D_i^-$ with $z_i^-(0) = x_i$, where D is the unit disc $\{z \in \mathbb{C} \mid |z| < 1\}$; and $z_i^+ : \hat{D} \rightarrow D_i^+$ with $z_i^+(\infty) = x_i$, where \hat{D} is the disc $\{z \in \hat{\mathbb{C}} = \mathbb{C} \cup \{\infty\} \mid 1 < |z|\}$. We assume the discs to be chosen such that their complement in X_0 contains an open subset that is a homotopy retract

of $X_0 \setminus \{x_1, \dots, x_k\}$.

Let B be a neighborhood of 0 in \mathbb{C}^{3g-3} . We will assign to each point in B a (possibly) noded surface and hence obtain a map to $\overline{\mathcal{M}}_g$, which maps a point in B to the class of the corresponding surface. By means of Beltrami differentials with support in the complement of discs we can describe the space of deformations of X_0 which change the complex structure outside discs. We identify the last $3g-3-k$ coordinates in B with a neighborhood of 0 in the tangent space of such deformations (see for example [H]). The first k coordinates describe opening up nodes, which leaves the complex structure in the complement of disks invariant. Since we can do it separately for each node, we will stick to one node and the corresponding coordinate.

Let $\lambda \in \mathbb{C}$, $0 < |\lambda| < 1$. Remove the image of $\{z \in D \mid |z| < |\lambda|\}$ from D^- and and the image of $\{z \in \hat{D} \mid |z| > |\lambda|^{-1}\}$ from D^+ ; identify the remainder of both discs by $z^+ \mapsto \lambda z^+$. We have replaced the pair of discs by a cylinder. As λ tends to zero, the hyperbolic length of the shortest core curve of the cylinder tends to zero, and by careful considerations we can recognize X_0 as limit surface.

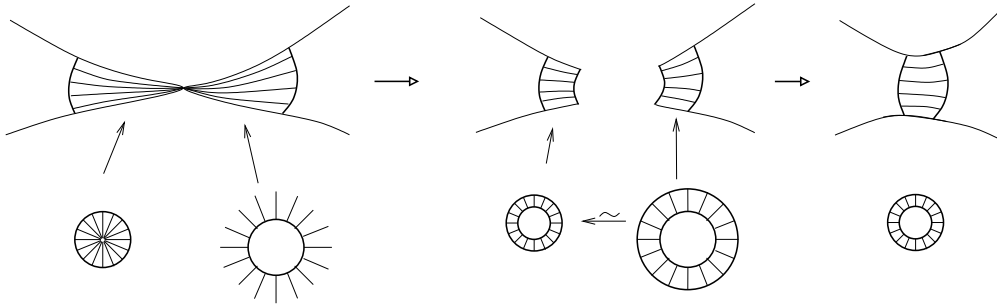

Figure 1: Opening up a node.

Orbifold structure on $\overline{\mathcal{M}}_g$. We do not go into details showing that such charts define an orbifold structure on $\overline{\mathcal{M}}_g$, and that the isotropy groups of the added points are automorphism groups of the corresponding noded surfaces. Note that although the chart depends on the choice of discs, the direction for “opening nodes without changing the complex structure outside” is well defined, it is normal to the set of surfaces having locally the maximal number of nodes.

For the finite covers of \mathcal{M}_g defined above, the compactification corresponding to $\overline{\mathcal{M}}_g$ is still not a manifold. However, $\overline{\mathcal{M}}_g$ is a good orbifold, as one can show by some generalization of the finite manifold cover construction for \mathcal{M}_g (see [Lo]), and the manifold covers are projective manifolds.

Compactification divisor. Let $x \in \overline{\mathcal{M}}_g \setminus \mathcal{M}_g$, let B be a coordinate neighborhood as in the opening-the-nodes-procedure. Then the divisor on B defined by $z_1 \cdots z_k = 0$ is invariant under the isotropy group of x , since each element of the group (which is an automorphism of the corresponding noded surface) preserves

the set of nodes. The collection of all such local divisors defines a divisor \mathcal{D} on $\overline{\mathcal{M}}_g$. The support of \mathcal{D} is the set $\overline{\mathcal{M}}_g \setminus \mathcal{M}_g$. Sometimes \mathcal{D} is called the divisor at infinity, since it is infinitely far away from any point in \mathcal{M}_g with respect to the Teichmüller distance. In the Weil-Petersson metric, $\overline{\mathcal{M}}_g$ is just the completion of \mathcal{M}_g .

Let x be a point in \mathcal{D} such that there is a non-separating node on the corresponding surface. Since non-separatedness is preserved by the automorphisms of the surface, we can analogously define the divisor \mathcal{D}_0 , whose support contains all such points. In the same manner we define \mathcal{D}_i , $1 \leq i \leq [\frac{g}{2}]$, whose support contains points corresponding to surfaces, where at least one pinched curve cuts off a subsurface of genus i . We immediately see that $\mathcal{D} = \sum_{i=0}^{[\frac{g}{2}]} \mathcal{D}_i$.

Bundles of holomorphic differentials. The cotangent bundle of \mathcal{M}_g is, by means of the cotangent bundle of \mathcal{T}_g , the orbifold of quadratic differentials $\Omega^2 \mathcal{M}_g$, more precisely, a fiber over a point in \mathcal{M}_g is the space of holomorphic quadratic differentials on the corresponding surface endowed with the action of automorphisms by pullbacks. The bundle of holomorphic 1-forms $\Omega \mathcal{M}_g$ is also easily constructed from the corresponding bundle on \mathcal{T}_g .

Universal curves. Let S be a surface of genus g , and $C \rightarrow B$ be a holomorphic bundle of marked Riemann surfaces, i.e. a topologically trivial bundle of surfaces of genus g with a fixed isomorphism $\pi_1(S) \rightarrow \pi_1(C_b)$ for some and hence every fiber of C . Then we obtain a map $B \rightarrow \mathcal{T}(S)$ assigning to every point the class of its fiber. This *classifying map* turns out to be holomorphic. There is a bundle of marked surfaces $\mathcal{C} \rightarrow \mathcal{T}(S)$ such that its pullback along the constructed base map $B \rightarrow \mathcal{T}(S)$ is biholomorphic to the original bundle C . Thus, holomorphic bundles of marked surfaces with base B are in 1-1 correspondence to holomorphic maps $B \rightarrow \mathcal{T}_g$. Because of this property the bundle \mathcal{C} is called the universal curve³. The bundle is easily constructed as a quotient of $\mathcal{T}_{g,1}$, the Teichmüller space of Riemann surfaces with one marked point, by a suitable action of $\pi_1(S)$.

Let $x \in \mathcal{T}(S)$ and let $S \rightarrow S_x$ be the corresponding marked surface. For $\phi \in \text{Map}(S)$ the fibers \mathcal{C}_x and $\mathcal{C}_{\phi(x)}$ are canonically isomorphic to S_x , and hence we obtain an action of Map_g on \mathcal{C} , which is a lift of the Map_g -action on \mathcal{T}_g . Let $\Gamma_x \subset \text{Map}_g$ be the isotropy group of $x \in \mathcal{T}_g$. By definition, Γ_x acts on \mathcal{C}_x as $\text{Aut}(\mathcal{C}_x)$ by canonical identification. Hence, fixed points of automorphisms of surfaces give rise to fixed points of the constructed action. Since the stabilizers of points in \mathcal{C} are finite, we obtain an orbifold structure on the quotient \mathcal{C}/Map_g . We have constructed a holomorphic bundle of Riemann surfaces $\mathcal{C}/\text{Map}_g \rightarrow \mathcal{M}_g$, however, only in the sense of orbifolds: the pullback to any chart neighborhood is a surface bundle, whereas fibers of the projection itself are the quotients $\mathcal{C}_x/\text{Aut}(\mathcal{C}_x)$. This bundle is again universal in the previous sense, this time in the orbifold category: orbifold surface bundles over an orbifold base B are in 1-1 correspondence to

³This notion comes from algebraic geometry and means relative curve = surface bundle.

orbifold morphisms $B \rightarrow \mathcal{M}_g$. The universal property is shown easily by passing to the universal covers of the bases of the bundles and using the universal property of the Teichmüller space. We denote this object also by \mathcal{C} and call it the universal curve by abuse of notation.

Moreover, the universal bundle of Riemann surfaces extends to a universal bundle of noded surfaces, which is a bundle over $\overline{\mathcal{M}}_g$. We denote this bundle again by \mathcal{C} and call it universal curve. If we take the algebraic definition of noded surface, i.e. fill the nodes, then this bundle is a projective orbifold, in the sense of finite manifold covers to be projective manifolds. Sometimes we will use the hyperbolic concept of surfaces with cusps, but we always mean the algebraic \mathcal{C} when dealing with (co)homology of the universal curve over \mathcal{M}_g . Note that although some fibers are singular, all fibers fit together to an orbifold. The space of nodes is a subspace of \mathcal{C} of complex codimension 2; hence, by classical theory of analytic spaces, the nodes are “very removable singularities”: roughly speaking, whatever is defined in the complement of nodes in \mathcal{C} , extends nicely to the nodes.

Relative tangent bundle. Let $\pi : \mathcal{C} \rightarrow \mathcal{M}_g$ be the universal curve of Riemann surfaces. Denote by $T_{\mathcal{C}/\mathcal{M}_g}$ the kernel of $d\pi : T\mathcal{C} \rightarrow T\mathcal{M}_g$, which is a subbundle of $T\mathcal{C}$ of rank one. This line bundle is called relative tangent bundle of the universal curve, since it consists of elements in $T\mathcal{C}$, which are tangent to fibers.

At first glance, it is not obvious how to define the corresponding line bundle on the universal curve of noded surfaces. Namely, in the singular points of noded surfaces, which are fibers of $\pi : \mathcal{C} \rightarrow \overline{\mathcal{M}}_g$, $d\pi$ nullifies at least two linear independent directions. However, we can use the algebraic definition of line bundles on analytic space X as locally free \mathcal{O}_X -modules of rank one.

More precisely, there is coordinate neighborhood of a node in \mathcal{C} and a coordinate neighborhood of its image in $\overline{\mathcal{M}}_g$, such that the projection in this coordinates is $\pi : D \times D \times D^{3g-4} \rightarrow D \times D^{3g-4}$, $(z_1, z_2, w_1, \dots, w_{3g-4}) \mapsto (z_1 z_2, w_1, \dots, w_{3g-4})$. One checks easily, that every holomorphic section in the tangent bundle that is nullified by $d\pi$, is a holomorphic multiple of $(z_1 \partial_{z_1} - z_2 \partial_{z_2})$, and thus the last section is a generator of the kernel of $d\pi$ viewed as a sheaf morphism.

Relative cotangent bundle. This is defined as the dual of the relative tangent bundle $T_{\mathcal{C}/\overline{\mathcal{M}}_g}$. The restriction of a holomorphic section in the relative cotangent bundle to a fiber is a holomorphic 1-form on the fiber. Thus, a holomorphic section in this bundle induces a holomorphic section in the bundle of 1-forms $\Omega\mathcal{M}_g$. In the nodes, we either proceed as before, showing that $\frac{dz_1}{z_1} - \frac{dz_2}{z_2}$ generates the bundle in the coordinates above, or we trust in the removability of singularities and do not care much about the nodes.

Mumford-Morita classes. Next we define the probably most prominent cohomological classes on $\overline{\mathcal{M}}_g$, the so-called Mumford-Morita classes. Let $0 \leq k \leq 3g - 3$, $\pi : \mathcal{C} \rightarrow \overline{\mathcal{M}}_g$ be the universal curve and $\pi_{\overline{\mathcal{L}}} : \mathcal{C}_{\overline{\mathcal{L}}} \rightarrow \overline{\mathcal{L}}$ be its pullback to a finite manifold cover $\overline{\mathcal{L}} \rightarrow \overline{\mathcal{M}}_g$. Let $e_{\overline{\mathcal{L}}} \in H^2(\mathcal{C}_{\overline{\mathcal{L}}}, \mathbb{Q})$ be the first Chern class of the relative tangent bundle. We define $\kappa_{k, \overline{\mathcal{L}}} \in H^{2k}(\overline{\mathcal{L}}, \mathbb{Q})$ to be the

image of $e_{\overline{\mathcal{L}}}^{k+1}$ under the Gysin morphism, i.e. take the Poincare dual of $e_{\overline{\mathcal{L}}}^{k+1}$ in $H_{6g-4-2(k+1)}(\mathcal{C}_{\overline{\mathcal{L}}}, \mathbb{Q})$, push it forward to $H_{6g-6-2k}(\overline{\mathcal{L}}, \mathbb{Q})$ and apply to the resulting class the inverse of the Poincare duality $H_{6g-6-2k}(\overline{\mathcal{L}}, \mathbb{Q}) \rightarrow H^{2k}(\overline{\mathcal{L}}, \mathbb{Q})$. We push $\kappa_{k, \overline{\mathcal{L}}}$ forward to $H^{2k}(\overline{\mathcal{M}}_g, \mathbb{Q})$ and call the image κ_k the k -th Mumford-Morita class. Note that the resulting class does not depend on the particular choice of the cover $\overline{\mathcal{L}}$.

Alternatively, we can push forward the powers of the Chern class of the universal curve's relative tangent bundle as elements in $H^*(\mathcal{C}, \mathbb{Q})$ to $H^{*-2}(\overline{\mathcal{M}}_g, \mathbb{Q})$; however, in this situation the classical Gysin morphism is a priori not defined.

Either way, we obtain a class κ_k with the following property: Let $W \xrightarrow{j} \overline{\mathcal{M}}_g$ be a compact (sub)orbifold of dimension k , let $\mathcal{C}_W \xrightarrow{j^c} \mathcal{C}$ be the preimage of W in \mathcal{C} . Then $(\kappa_k, j_*^c[\mathcal{C}_W]) = (e^{k+1}, j_*[W])$, where $(\cdot, \cdot) : H^i(X, \mathbb{Q}) \times H_i(X, \mathbb{Q}) \rightarrow \mathbb{Q}$ is the usual pairing for $X = \overline{\mathcal{M}}_g$, \mathcal{C} , and $[\mathcal{C}_W]$ and $[W]$ are the fundamental classes.

2 Flat and translation surfaces

Let X be a Riemann surface and ω be a holomorphic quadratic differential on X , i.e. a holomorphic section in $T^*X \otimes_X T^*X$. Let Z be the set of zeros of ω . Let $U \subset X - Z$ be a simply connected neighborhood of $p_0 \in X$. Let $\sqrt{\omega}$ be a holomorphic 1-form on U with $\sqrt{\omega} \otimes \sqrt{\omega} = \omega$. Such a root exists and is unique up to multiplication by ± 1 . Since $\sqrt{\omega}$ is holomorphic, the integral $\int_{p_0}^p \sqrt{\omega}$ depends only on $p \in U$ and not on a particular path in U from p_0 to p . Hence, we obtain a locally biholomorphic map $U \rightarrow \mathbb{C}$, which we call a chart for X natural with respect to ω . One checks immediately that a transition map of two natural charts is a translation in \mathbb{C} , possibly followed by $-\text{id}_{\mathbb{C}}$ due to the choice of the root; we obtain an atlas for $X - Z$ with this property. Note that the restriction of ω to U is just the pullback of $dz^2 := dz \otimes dz$ via the natural chart.

On the other hand, given a topological surface (possibly non-compact) with an atlas such that the transition maps are restrictions of \pm -translations on $\mathbb{R}^2 = \mathbb{C}$, we obtain a complex structure on the surface and a non-vanishing holomorphic quadratic differential by patching together the pullbacks of dz^2 .

The zeros of ω in X and, correspondingly, punctures of the topological surface in the backward construction require more careful consideration, but we do not go into these details. We just note that most of the problems with these points are handled by Riemann's theorem on removable singularities.

Definition 2.1. A half-translation or flat surface is a pair (X, ω) , with a Riemann surface X and a holomorphic quadratic differential ω on X .

By means of the natural atlas we obtain further structure on a flat surface. Since the transitions are \pm -translations, hence isometries of \mathbb{C} , we can pull back the euclidean metric on \mathbb{C} to a euclidean metric on $X - Z$. The metric can be

continued to X , however, it becomes singular in Z . Later on, we will see what it looks like in a neighborhood of a zero of ω .

For a tangent vector on X with base point outside Z , the argument $\in [0; 2\pi)$ measured in a natural chart is well-defined up to π . Hence, we have a notion of direction $\in [0; \pi)$. The geodesics in the constructed metric on $X - Z$ are lines of constant direction, and for any direction $\theta \in [0; \pi)$ we obtain a foliation of $X - Z$ by geodesics with direction θ . For instance, we have the so-called horizontal foliation in the direction $\theta = 0$, and the vertical foliation in the direction $\theta = \frac{\pi}{2}$, which is orthogonal to the horizontal one with respect to the metric.

Let us take a closer look at the zeros of ω . Let $z \in Z$ and let $U \rightarrow \mathbb{C}$ be a chart neighborhood of z such that ω is the pullback of $z^k dz^2$. The preimages of lines $l_j : (0, \epsilon) \rightarrow \mathbb{C}, t \rightarrow te^{2\pi i \frac{j}{k+2}}$ for $j = 0, \dots, k+1$ are horizontal, as one can see by integrating a local square root of ω . Each of the $k+2$ regions between them get mapped by a natural chart onto a neighborhood of zero in a half-plane.

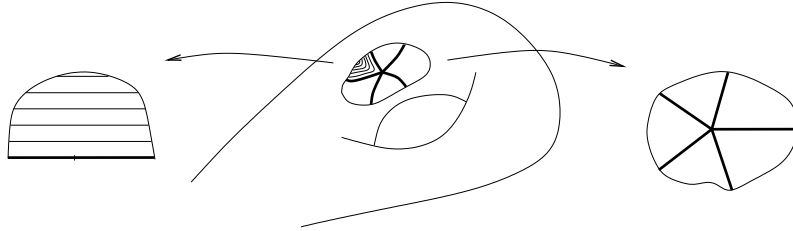

Figure 2: The half-planes bounded by the horizontal half-leaves. In the right coordinate $\omega = z^k dz$; the left coordinate is ω -natural.

Hence, extending the metric on $X - Z$ into z , we obtain a conical singularity with angle $(k+2)\pi$. For each direction θ there are $(k+2)$ θ -half-leaves starting in the zero. The foliations and the metric are singular in Z , and we refer to the zeros of ω as singularities.

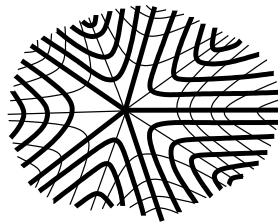

Figure 3: The horizontal and the vertical foliations close to a zero of ω .

Given a holomorphic 1-form α on a Riemann surface X we can do analogous constructions, without choosing a square root. In this case transitions between

natural charts are translations, the directions are well-defined in $[0; 2\pi)$ and the foliation is oriented. At a zero of order k we see $2(k + 1)$ half-planes.

Definition 2.2. A translation or very flat surface is a pair (X, α) , with Riemann surface X and a holomorphic 1-form α on X .

These flat surfaces are sometimes easier to handle. In the general case, the orientation cover for any θ -foliation is very flat; so, dealing with very flat surfaces is often sufficient.

Flat surfaces are usually constructed from polygons in \mathbb{C} by gluing parallel sides, as indicated in the following figure. More precisely, assume a set of polygons given, whose sides are ordered in pairs, each consisting of two parallel sides of the same length. For each pair there is a unique \pm -translation mapping one side to the other, such that one side's inner normal direction get mapped to the other side's outer normal direction. Identification of each pair along this map yields an oriented compact flat surface, with quadratic differential dz^2 . In the case that only translations are involved, we obtain a very flat surface with differential dz .

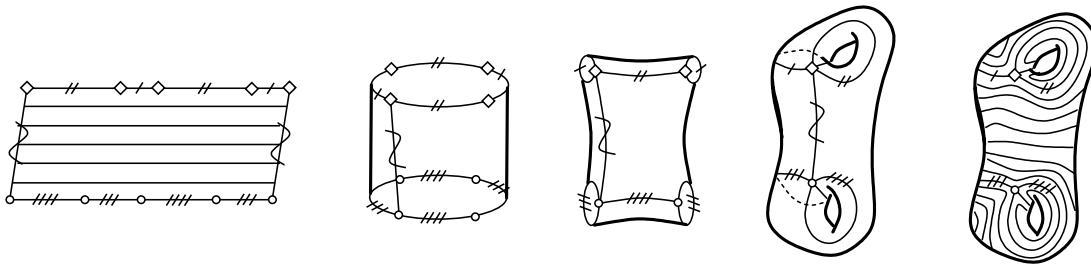

Figure 4: Gluing a flat surface from a polygon. In the first and the last images we see the horizontal foliation.

The angles at the singularities of the constructed surface are positive multiples of π . In some special cases we obtain an angle π , accordingly, the quadratic differential has a representation $\frac{1}{z}dz^2$ in a neighborhood of the singularity, and is therefore not holomorphic; these cases should be excluded.

The probably most famous examples are the L-surfaces and the origami. The first arise from L-shaped polygons with identifications as in the following figure. These surfaces have genus 2 and were studied e.g. by McMullen in [McM1] and Bainbridge in [Ba]. Origami are constructed by gluing finitely many copies of a square. For detailed discussion of examples see the next section.

Finally we want to mention the special case when for some direction θ , every θ -half-leaf starting in a singularity runs into a singularity. Then, cutting the surface along all singular θ -leaves we obtain a collection of nonsingular euclidean surfaces with nonempty⁴ geodesic boundary, which are cylinders by the Gauss-

⁴In the exceptional case of a torus, the boundary is empty, since quadratic differentials have no singularities.

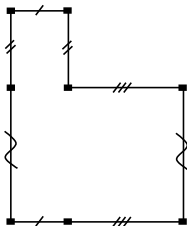

Figure 5: L-surface.

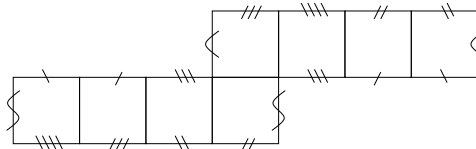

Figure 6: An origami: "Eierlegende Wollmilchsau".

Bonnet theorem. Any nonsingular θ -leaf is contained in one of these cylinders, and is parallel to the boundary, hence closed. We call this decomposition of the surface the cylindrical decomposition in direction θ . The example in the Figure 4 has one horizontal cylinder; the surfaces in the last two figures decompose into two horizontal cylinders as well as into two vertical ones.

3 Teichmüller discs and curves

3.1 Teichmüller discs

Let $i \in \mathbb{C}$ be the imaginary unit, $\operatorname{Im} \lambda$ and $\operatorname{Re} \lambda$ be the real and imaginary parts of a complex number $\lambda = \operatorname{Re} \lambda + i \operatorname{Im} \lambda$.

We start with the action of $\operatorname{PSL}_2 \mathbb{R} = \operatorname{SL}_2 \mathbb{R} / \{\pm 1\}$ on the lower half-plane $\overline{\mathbb{H}} = \{z \in \mathbb{C} \mid \operatorname{Im} z < 0\}$ by Möbius transformations⁵⁶. This action determines an anti-action on the cotangent bundle of the lower halfplane $T^* \overline{\mathbb{H}}$, which extends to an anti-action of $\operatorname{GL}_2^+ \mathbb{R} / \{\pm 1\}$ on $T^* \overline{\mathbb{H}}$ by $A \bullet (w, u) = (\mu_A^{-1}(w), \det A \cdot (\mu_A)_w^* u)$, where $u \in T_w^* \overline{\mathbb{H}}$, μ_A is the Möbius transformation defined by A , and $(\mu_A)_w^* : T_w^* \overline{\mathbb{H}} \rightarrow T_{\mu_A^{-1}(w)}^* \overline{\mathbb{H}}$ is its pullback. The restriction of the last anti-action to the bundle of non-zero cotangent vectors $\dot{T}^* \overline{\mathbb{H}}$ is transitive and free, and therefore, for any choice of $(w, u) \in \dot{T}^* \overline{\mathbb{H}}$ we obtain a bijective map $A \mapsto A \bullet (w, u)$.

For $(w, u) = (-i, dw)$ there is another useful description of this orbit map: For $\lambda \in \mathbb{C}^*$ let $U_\lambda = \begin{pmatrix} \operatorname{Re} \lambda & -\operatorname{Im} \lambda \\ \operatorname{Im} \lambda & \operatorname{Re} \lambda \end{pmatrix}$ be the representation of multiplication by λ on $\mathbb{C} = \mathbb{R}^2$ as a real matrix. For $w \in \overline{\mathbb{H}}$ set $A_w := \begin{pmatrix} 1 & -\operatorname{Re} w \\ 0 & -\operatorname{Im} w \end{pmatrix}$. Then, using KAN-decomposition, we can decompose any $A \in \operatorname{GL}_2^+ \mathbb{R}$ as $A = U_\lambda A_w$ with unique λ and w .

⁵We use w for the coordinate on $\overline{\mathbb{H}}$, keeping z reserved for a natural coordinate on a translation surface.

⁶For $M = \begin{pmatrix} a & b \\ c & d \end{pmatrix}$, the Möbius transformation $\mu_M : \mathbb{C} \rightarrow \mathbb{C}$ is defined by $w \mapsto \frac{aw+b}{cw+d}$, which is a holomorphic map preserving \mathbb{H} and $\overline{\mathbb{H}}$.

Lemma 3.1. *Let $A = U_\lambda A_w$. Then $A \bullet (-i, dw) = (w, \lambda^2 dw)$.*

PROOF. We deduce $\mu_A^{-1}(-i) = w$ from the following computation:

$$\mu_A(w) = \mu_{U_\lambda}(\mu_{A_w}(w)) = \mu_{U_\lambda}\left(\frac{\operatorname{Re} w + i \operatorname{Im} w - \operatorname{Re} w}{-i \operatorname{Im} w}\right) = \mu_{U_\lambda}(-i) = \left(\frac{-i \operatorname{Re} \lambda - \operatorname{Im} \lambda}{-i \operatorname{Im} \lambda + \operatorname{Re} \lambda}\right) = -i.$$

Denote by $\mu'|_v$ the derivative of μ in $v \in \overline{\mathbb{H}}$. Using $(\mu_M)'|_v = \frac{ad-bc}{(cv+d)^2}$ for $M =$

$$\begin{pmatrix} a & b \\ c & d \end{pmatrix}, \text{ we obtain } \mu'_{U_\lambda}|_{-i} = \frac{\lambda \bar{\lambda}}{\bar{\lambda}^2} = \frac{\lambda}{\bar{\lambda}}, \text{ where } \bar{\lambda} = \operatorname{Re} \lambda - i \operatorname{Im} \lambda; \text{ and we obtain}$$

$$\mu'_{A_w}|_w = \frac{-i \operatorname{Im} w}{(\operatorname{Im} w)^2} = -\frac{1}{\operatorname{Im} w}. \text{ This implies } (\mu_A)^*_{-i}(dw) = (\mu_{U_\lambda A_w})'|_w dw = \mu'_{U_\lambda}|_{A_w(w)} \cdot (\mu_{A_w})'|_w dw = -\frac{\lambda}{\lambda \operatorname{Im} w} dw. \text{ The computation of } \det A = \det U_\lambda \cdot \det A_w = \lambda \bar{\lambda} \cdot (-i \operatorname{Im} w) \text{ completes the proof. } \square$$

Note that under this identification the anti-action of $\operatorname{SL}_2 \mathbb{R}$ by multiplication from the right on $\operatorname{GL}_2^+ \mathbb{R} / \{\pm 1\}$ corresponds to the anti-action by pullbacks of Möbius transformations on $\dot{\mathbb{T}}^* \overline{\mathbb{H}}$, which are holomorphic and can be extended to $\mathbb{T}^* \overline{\mathbb{H}}$.

On the other hand, $\operatorname{GL}_2^+ \mathbb{R}$ acts on the space of marked translation surfaces $\Omega^2 \mathcal{T}_g$ as follows. Given a translation surface (X, ω) and an $A \in \operatorname{GL}_2^+ \mathbb{R}$, we construct a new translation surface $A(X, \omega)$: Take the natural atlas with \pm -translations as transition maps and postcompose every natural chart with A . This produces a new atlas, where the transition maps are the old transitions conjugated by A , and hence are \pm -translations too. Again, we do not go into details concerning zeros of ω , but it is easy to see that this new structure gives rise to a new Riemann surface and a holomorphic quadratic differential on it. Though AX is not well-defined without ω , we will use this notation for the Riemann surface underlying $A(X, \omega)$, if the differential is clear from context. This defines an action of $\operatorname{GL}_2^+ \mathbb{R}$ on the moduli space of quadratic differentials $\Omega^2 \mathcal{M}_g$. To lift this action to $\Omega^2 \mathcal{T}_g$, we note that the underlying topological space for X and AX is the same, by definition. The identity on the topological space is a homeomorphism $\operatorname{id}_A : X \rightarrow AX$, which we postcompose with a marking for X to obtain a marking for AX . We will suppress the markings in the notation, as long no confusions can arise. The next examples are simple but useful:

- $U_\lambda(X, \omega) = (X, \lambda^2 \omega)$, in particular $U_\lambda X = X$.
- $A(t) = \begin{pmatrix} e^{\frac{t}{2}} & 0 \\ 0 & e^{-\frac{t}{2}} \end{pmatrix}$ describes a Teichmüller deformation of X , which has the minimal quasiconformal constant in the homotopy class of $\operatorname{id}_A : X \rightarrow AX$. The map $\mathbb{R} \rightarrow \mathcal{T}_g$, $t \mapsto A(t)X$ is the Teichmüller geodesic generated by (X, ω) , see [Ab] for details.

The stabilizers of the constructed action of $\operatorname{GL}_2^+ \mathbb{R}$ on $\Omega^2 \mathcal{T}_g$ obviously contain ± 1 ; therefore, for a fixed (X, ω) , we obtain a map $\dot{\mathbb{T}}^* \overline{\mathbb{H}} \rightarrow \Omega^2 \mathcal{T}_g$, $A \bullet (-i, dw) \mapsto A(X, \omega)$, which extends to $J : \mathbb{T}^* \overline{\mathbb{H}} \rightarrow \Omega^2 \mathcal{T}_g$ by $J(w, 0) = (A_w X, 0)$. Since

$U_\lambda A_w X = A_w X$, this map descends to $j : \overline{\mathbb{H}} \rightarrow \mathcal{T}_g$, $j : w \mapsto A_w X$, as indicated in the following commutative diagram:

$$\begin{array}{ccc}
 & GL_2^+ \mathbb{R} & \\
 & \swarrow & \searrow \\
 \Omega^2 \mathcal{T}_g & \xleftarrow{J} & \mathbb{T}^* \overline{\mathbb{H}} \\
 \downarrow \pi & & \downarrow \pi \\
 \mathcal{T}_g & \xleftarrow{j} & \overline{\mathbb{H}}
 \end{array}$$

Definition 3.2. We call the map j in the diagram the Teichmüller disc generated by (X, ω) .

Before we proceed to the properties of the Teichmüller curves, we state the following easy fact, which follows directly from the definitions.

Fact 3.3. Let $B \in SL_2^+ \mathbb{R}$ and (X, ω) a (marked) flat surface. Let j_B be the Teichmüller disc defined by $B(X, \omega)$, and J_B analogous. Then $J_B(A \bullet (-i, dw)) = AB(X, \omega) = J \circ \mu_B^*(A \bullet (-i, dw))$ and $j_B = j \circ \mu_B^{-1}$.

3.2 Properties of Teichmüller discs

The next two lemmas show why Teichmüller curves are sometimes called complex geodesics.

Lemma 3.4. j is isometric with respect to the Poincare and Teichmüller metrics, in particular injective.

PROOF. First observe that j maps the geodesic $\gamma_0 : \mathbb{R} \rightarrow \overline{\mathbb{H}}$, $t \mapsto -e^{-t}i$ to $j \circ \gamma_0 : t \mapsto \begin{pmatrix} 1 & 0 \\ 0 & e^{-t} \end{pmatrix} X = \begin{pmatrix} e^{-\frac{t}{2}} & 0 \\ 0 & e^{-\frac{t}{2}} \end{pmatrix} \begin{pmatrix} e^{\frac{t}{2}} & 0 \\ 0 & e^{-\frac{t}{2}} \end{pmatrix} X$, which, by combination of the two examples above, is a Teichmüller geodesic.

Let $\gamma : \mathbb{R} \rightarrow \overline{\mathbb{H}}$ be any other geodesic. Then there exists $B \in SL_2 \mathbb{R}$ such that $\gamma = \mu_{B^{-1}} \circ \gamma_0$. By the above fact, $j \circ \gamma = j_B \circ \gamma_0$, hence j maps a Poincare geodesic to a Teichmüller geodesic. Since both metric spaces are uniquely geodesic, this proves the statement of the lemma. \square

Lemma 3.5. j is holomorphic.

PROOF. Let $B_1(X)$ be the unit ball in the Banach space of Beltrami differentials on X , i.e. $(-1, 1)$ -forms, endowed with the L_∞ -norm. The map $B_1(X) \xrightarrow{\pi} \mathcal{T}(X)$ mapping $\beta \in B_1(X)$ to the class of the unique $f_\beta : X \rightarrow X_\beta$ with $\frac{\bar{\partial} f_\beta}{\partial f_\beta} = \beta$ is holomorphic by definition of the complex structure on \mathcal{T}_g (see [H]).

For $w \in \overline{\mathbb{H}}$ let $f_w := \text{id}_{A_w} : X \rightarrow A_w X$ be the identity map, which is multiplication by A_w in the natural charts of (X, ω) and $A_w(X, \omega)$, hence $f_w(z) = \text{Re } z - \text{Im } z \text{Re } w - i \text{Im } z \text{Im } w = \text{Re } z - w \text{Im } z$. This implies $\beta(f_w)(z) = \frac{\partial_z f_w}{\partial_z f_w} \frac{d\bar{z}}{dz} = \frac{1-iw}{1+iw} \frac{d\bar{z}}{dz} = \frac{i+w}{i-w} \frac{d\bar{z}}{dz}$.

We see that $I : \overline{\mathbb{H}} \rightarrow B_1(X)$, $w \mapsto \beta(f_w)$ is holomorphic $\Rightarrow j = \pi \circ I$ is holomorphic. \square

Corollary 3.6. Let j_i be the Teichmüller disc generated by (X_i, ω_i) , for $i = 1, 2$. If $j_1(\overline{\mathbb{H}}) = j_2(\overline{\mathbb{H}})$, then there exists $B \in \mathrm{GL}_2^+ \mathbb{R}$ such that $B(X_1, \omega_1) = (X_2, \omega_2)$. The matrix B is unique up to $\{\pm 1\}$.

PROOF. Since j_i are holomorphic isometric imbeddings, the map $j_1^{-1} \circ j_2$ is an orientation preserving isometry of $\overline{\mathbb{H}}$, hence, there exists a matrix $B \in \mathrm{SL}_2 \mathbb{R}$ such that $j_2 = j_1 \circ \mu_B^{-1}$. By the Fact 3.3 we obtain $j_2 = (j_1)_B$.

In the proof of the isometry of j , we have seen that the generator of a Teichmüller disc j generates the Teichmüller geodesic $j \circ \gamma_0$, and hence is unique up to scaling (see [Ab]), which is achieved by multiplication with a multiple of the unit matrix. Hence, there is a unique diagonal matrix D such that $D(X_2, \omega_2) = B(X_1, \omega_1)$. The statement of the corollary follows now. \square

Let X be a marked Riemann surface. Recall the identification of the space of holomorphic quadratic differentials on X with the cotangent space of \mathcal{T}_g at the corresponding point x : A quadratic differential ω on X defines a linear map $T_0 B_1(X) \cong B_1(X) \rightarrow \mathbb{C}$ by $\beta \mapsto \int_X \omega \beta$, which descends via $T_0 B_1(X) \rightarrow T_x \mathcal{T}_g$ to a linear map $T_x \mathcal{T}_g \rightarrow \mathbb{C}$, see [H] for details. The next rather technical lemma gives the last bit of information on j that we will need:

Lemma 3.7. *If the euclidean area of (X, ω) equals 1, then $j^* \circ J = \frac{1}{2i} \mathrm{id}_{T^* \overline{\mathbb{H}}}$, more precisely $j^*(A(X, \omega)) = \frac{1}{2i}(A \bullet (-i, dw))$, where the multiplication in $T^* \overline{\mathbb{H}}$ is fiberwise.*

PROOF. Let $A = U_\lambda$. Note that $A(X, \omega) = (X, \lambda^2 \omega)$ and $A \bullet (-i, dw) = (-i, \lambda^2 dw)$. We also have $I_*(-i, \partial_w) = (0, \frac{2i}{(i+i)^2} \frac{d\bar{z}}{dz}) \in T_0 B_1(X)$ in ω -natural coordinate z . Then $\langle A(X, \omega), j_*(-i, \partial_w) \rangle = \int_X \lambda^2 dz^2 \frac{1}{2i} \frac{d\bar{z}}{dz} = \frac{\lambda^2}{2i} \int_X dz d\bar{z} = \frac{\lambda^2}{2i}$. Hence, $\langle j^*(A(X, \omega)), (-i, \partial_w) \rangle = \frac{\lambda^2}{2i} \Rightarrow j^*(A(X, \omega)) = \frac{\lambda^2}{2i}(-i, dw) = \frac{1}{2i}(A \bullet (-i, dw))$.

Let $A \in \mathrm{GL}_2^+ \mathbb{R}$ be arbitrary. Decompose A as $U_\lambda B$ with $B \in \mathrm{SL}_2 \mathbb{R}$. Applying the first part of the proof to j_B , and using Fact 3.3 we compute

$$\begin{aligned} j^*(U_\lambda B(X, \omega)) &= (j_B \circ \mu_B)^*(U_\lambda B(X, \omega)) = \mu_B^*(j_B^*(U_\lambda(B(X, \omega)))) \\ &= \frac{1}{2i} \mu_B^*(U_\lambda \bullet (-i, dw)) = \frac{1}{2i}(U_\lambda B \bullet (-i, dw)). \end{aligned} \quad \square$$

Definition 3.8. Let (X, ω) be a flat surface. The cotangent bundle \mathcal{B}^2 of the Teichmüller disc generated by (X, ω) is the image of J in $\Omega^2 \mathcal{T}_g$, with the projection $\pi \circ J^{-1} : \mathcal{B}^2 \rightarrow \overline{\mathbb{H}}$. It is a line bundle isomorphic to $T^* \overline{\mathbb{H}}$ via $j^* \circ J = \frac{1}{2i} \mathrm{id}_{T^* \overline{\mathbb{H}}}$ and $J \circ j^* = \frac{1}{2i} \mathrm{id}_{\mathcal{B}^2}$.

3.3 Teichmüller curves

In this section the action of the mapping class group comes into play, therefore we denote all the markings; if the marking is not noted we mean the underlying complex structure only. Let X be a Riemann surface. For simplicity of notation, instead of \mathcal{T}_g and Map_g we will use $\mathcal{T}(X)$ and $\text{Map}(X)$, the models based on X , i.e. the elements of $\mathcal{T}(X)$ are classes of pairs (Y, f) with Y Riemann surface and $f : X \rightarrow Y$ etc.

Recall the definition of the action of $\text{Map}(X)$ on $\mathcal{T}(X)$: Let ϕ denote a mapping class on X or some representative of the class. Then precomposition of ϕ^{-1} to the markings defines a self-map of $\mathcal{T}(X)$ which respects all involved structures, in particular, it is holomorphic. We denote this automorphism of $\mathcal{T}(X)$ by Φ . On the cotangent bundle of $\mathcal{T}(X)$ we obtain an anti-action of $\text{Map}(X)$ by pullbacks. In terms of identification of $T^*\mathcal{T}(X)$ with $\Omega^2\mathcal{T}(X)$ this anti-action is by precomposition ϕ to markings of flat surfaces: $(Y, f, \omega) \xrightarrow{\Phi^*} (Y, f \circ \phi, \omega)$.

Let j and J be the maps defined by (X, id, ω) as in the previous section. Then $\Phi^{-1} \circ j$ and $\Phi^* \circ J$ are the corresponding maps defined by the marked flat surface $\Phi^*(X, \text{id}, \omega) = (X, \phi, \omega)$, which follows from the definition of Teichmüller discs. In particular, $\text{Map}(X)$ acts on the set of Teichmüller discs, respecting their cotangent bundles.

Now assume that Φ stabilizes the image of the Teichmüller disc generated by (X, id, ω) . Applying Corollary 3.6 to the Teichmüller discs $\Phi^{-1} \circ j$ and j we obtain a unique $M(\phi) \in \text{GL}_2^+ \mathbb{R} / \pm \mathbb{1}$ such that $\Phi^*(X, \text{id}, \omega) = M(\phi)(X, \text{id}, \omega)$. By Fact 3.3 we obtain $\Phi^{-1} \circ j = j \circ \mu_{M(\phi)^{-1}}$, hence, the pullback of $\Phi : \mathcal{T}(X) \rightarrow \mathcal{T}(X)$ to $\overline{\mathbb{H}}$ via j is $j^{-1} \circ \Phi \circ j = \mu_{M(\phi)}$.

From $(X, \phi, \omega) = \Phi^*(X, \text{id}, \omega) = M(\phi)(X, \text{id}, \omega)$ we deduce another important property of $M(\phi)$: there exists a holomorphic map $c : M(\phi)X \rightarrow X$ respecting the flat structure, i.e. being \pm -translation in the natural coordinates, such that $c \circ \text{id}_{M(\phi)}$ is homotopic to ϕ . Then $c \circ \text{id}_{M(\phi)} : X \rightarrow X$ is a representative of the homotopy class of ϕ , which is affine with respect to ω -natural coordinates with derivative $M(\phi)$.

We denote by $\text{Stab}_{\text{Map}(X)} j(\overline{\mathbb{H}})$ the subgroup of $\text{Map}(X)$ stabilizing the image of the Teichmüller disc generated by (X, id, ω) , and by $\text{Aff}(X, \omega)$ the subgroup of $\text{Map}(X)$ consisting of homotopy classes having affine representatives. We have proved $\text{Stab}_{\text{Map}(X)} j(\overline{\mathbb{H}}) \subset \text{Aff}(X, \omega)$. For the converse, let ϕ be an affine diffeomorphism of (X, ω) , let $M \in \text{GL}_2^+ \mathbb{R} / \{\pm \mathbb{1}\}$ be its derivative, which is obviously constant. Then $c := \phi \circ \text{id}_M^{-1} : MX \rightarrow X$ is a \pm -translation in the natural coordinates, hence, holomorphic. We conclude $c \circ \text{id}_M = \phi \Rightarrow (X, \phi, \omega) = M(X, \text{id}, \omega) \Rightarrow \Phi \in \text{Stab}_{\text{Map}_g} j(\overline{\mathbb{H}})$.

Note that the matrices in question must preserve the euclidean area of the flat surfaces and are therefore elements of $\text{PSL}_2 \mathbb{R}$.

We now switch back to the usual notation. In the following diagram the

horizontal arrows are isomorphisms; and the left vertical arrow takes derivative of some affine representative, which is well defined since everything else is. We have shown that the diagram commutes.

$$\begin{array}{ccc}
 \text{Map}_g \supset \text{Aff}(X, \omega) & \xrightarrow{\sim} & \text{Stab}_{\text{Map}_g} j(\overline{\mathbb{H}}) \subset \text{Aut}(\mathcal{T}_g) \\
 \text{Der} \downarrow & \begin{array}{ccc} \phi & \longmapsto & \Phi \end{array} & \downarrow & \begin{array}{ccc} \Phi & & \\ & \downarrow & \\ & j^{-1} \circ \Phi \circ j & \end{array} \\
 \text{PSL}_2 \mathbb{R} & \xrightarrow{\sim} & \text{Isom}(\overline{\mathbb{H}}) \\
 M & \longmapsto & \mu_M
 \end{array}$$

Note that the image of the right vertical arrow acts properly discontinuously on $\overline{\mathbb{H}}$ since $\text{Stab}_{\text{Map}_g} j(\overline{\mathbb{H}})$ does on \mathcal{T}_g , hence, we can pass to the quotients. The kernel of the vertical arrows is $\text{Aut}(X, \omega) = \{\phi \in \text{Aut}(X) | \phi^*(\omega) = \omega\}$, in particular, finite. We obtain a morphism of orbifolds $\overline{\mathbb{H}} / \text{Stab}_{\text{Map}_g} j(\overline{\mathbb{H}}) \rightarrow \mathcal{M}_g$, which we call j again, by abuse of notation.

Definition 3.9. Let $j : \overline{\mathbb{H}} \rightarrow \mathcal{T}_g$ be the Teichmüller disc generated by (X, ω) . The Veech group $G(X, \omega) \subset \text{PSL}_2 \mathbb{R}$ of the flat surface (X, ω) is the image of the vertical arrows in the previous diagram. The extended Veech group is $\Gamma(X, \omega) := \text{Aff}(X, \omega) = \text{Stab}_{\text{Map}_g} j(\overline{\mathbb{H}}) \subset \text{Map}_g$, which is an extension of $G(X, \omega)$ by $\text{Aut}(X, \omega)$. If the Veech group of (X, ω) is a lattice, we call (X, ω) a Veech surface, and the orbifold morphism $C := \overline{\mathbb{H}} / \Gamma(X, \omega) \rightarrow \mathcal{M}_g$ the Teichmüller curve generated by (X, ω) . The cotangent bundle of the Teichmüller curve is the quotient of \mathcal{B}^2 by $\Gamma(X, \omega)$, which is a line bundle over C isomorphic to T^*C . We abuse the names j, J , and \mathcal{B}^2 for the corresponding “quotiented” objects.

$$\begin{array}{ccccc}
 & & \text{GL}_2^+ \mathbb{R} & & \\
 & \swarrow & & \searrow & \\
 \Omega^2 \mathcal{M}_g & \leftarrow \mathcal{B}^2 & & & T^*C \\
 \downarrow \pi & & & & \downarrow \pi \\
 \mathcal{M}_g & \xleftarrow{j} & & & C
 \end{array}$$

Note that the new j is not necessarily an imbedding due to possible self-intersections, however it is a holomorphic immersion; analogously the total space of \mathcal{B}^2 is not a subset of $\Omega^2 \mathcal{M}_g$.

The isotropy groups of the orbifold C may all be nontrivial, since they contain $\text{Aut}(X, \omega)$. If, for instance, (X, ω) is hyperelliptic, so is any $A(X, \omega)$, and the hyperelliptic involution fixes $j(\overline{\mathbb{H}})$ pointwise.

Let $C \rightarrow \mathcal{M}_g$ be a Teichmüller curve. Since C is of finite type, passing to a finite normal manifold cover of $\overline{\mathcal{M}}_g$ and coming back, we observe that there

exists a canonical compactification $\overline{C} \supset C$ and a holomorphic extension of j to $\overline{C} \rightarrow \overline{\mathcal{M}}_g$, such that $\overline{C} \setminus C$ is a finite set. In the section 4 we will see that the image of the additional points lies in the boundary $\overline{\mathcal{M}}_g - \mathcal{M}_g$; from this we deduce that $j(C)$ is closed in \mathcal{M}_g . Though we will not need it, we want to mention that the converse is also true: if the image of the Teichmüller disc generated by (X, ω) is closed in \mathcal{M}_g , then (X, ω) is a Veech surface; for a sketch of the proof see [V95].

3.4 Abelian Teichmüller curves

In the case that the generator of a Teichmüller disc or curve is a very flat surface, i.e. we start with a holomorphic 1-form rather than quadratic differential, we obtain a somewhat finer structure over C .

Let $\Omega\mathcal{T}_g$ be the bundle of holomorphic 1-forms. Analogously to the case of quadratic differentials we define an action of $\mathrm{GL}_2^+ \mathbb{R}$ on the bundle by post-composing natural charts with a matrix. Given $(X, \alpha) \in \Omega\mathcal{T}_g$, we obtain a bundle $\mathcal{B} \subset \Omega\mathcal{T}_g$ over the Teichmüller disc generated by (X, α^2) consisting of $\mathrm{GL}_2^+ \mathbb{R}(X, \alpha)$ and the zero section. The bundle morphism $\Omega\mathcal{T}_g \times \Omega\mathcal{T}_g \rightarrow \Omega^2\mathcal{T}_g$, $((Y, \alpha_1), (Y, \alpha_2)) \mapsto (Y, \alpha_1 \otimes \alpha_2)$ defines an isomorphism of line bundles $\mathcal{B} \otimes \mathcal{B} \rightarrow \mathcal{B}^2$. The bundle \mathcal{B} and the last isomorphism descend to bundles on $\overline{\mathbb{H}}/\mathrm{Stab}_{\mathrm{Map}_g} j(\overline{\mathbb{H}}) = C$.

3.5 Examples

As mentioned in Section 2, examples of flat surfaces usually arise from polygons by gluing parallel sides. We give now some examples of flat surfaces and information on their Veech groups, as well as some Teichmüller curves constructed in other ways. Although the list is not complete, up to cover construction in Example 3, there are only some further sporadic examples of Veech surfaces known.

Example 1. Starting with a square, whose sides are labeled counterclockwise by a, b, c and d , we identify a with c and b with d to obtain a standard torus T . The Veech group of a square is obviously $\mathrm{PSL}_2 \mathbb{Z}$, and the generated Teichmüller curve is the entire moduli space \mathcal{M}_1 , which is regarded as the trivial example.

Example 2. Given a finite set of equal squares $P_i, i \in \{1, \dots, n\}$ with sides a_i, b_i, c_i and $d_i, i \in \{1, \dots, n\}$, we can identify each a -side with some c -side and each b -side with some d -side to obtain a (possibly disconnected) flat surface S and a branched cover $S \rightarrow T$. This map is branched at most over one point and is a local isometry outside the branch points, which are singularities on S . Such surfaces are called origami or square tiled surfaces. Gutkin and Judge proved in [GJ] that the Veech group of a flat surface is commensurable to $\mathrm{PSL}_2 \mathbb{Z}$ if and only if the surface is square tiled. [SchTh] contains an elementary introduction to origami as well as an algorithm that computes a Veech group of an origami in

terms of generators and relations⁷. A nice example of an origami with many nice properties is the “Wollmilchsau” in the Figure 6, for details see [HeSch].

Example 3. The analog of the previous construction can be applied to any polygon. Even more generally, given a flat surface (S_1, ω_1) and a finite holomorphic branched cover $S_2 \xrightarrow{p} S_1$, we obtain a flat surface $(S_2, p^*\omega_1)$ that inherits some information from (S_1, ω_1) . For instance, if the cover is branched over singularities only⁸, then the Veech groups of S_1 and S_2 are commensurable, see [GJ]. The Teichmüller curves that do not arise via this cover construction are called primitive.

Example 4. L-shaped polygons, see Figure 5, deliver flat surfaces of genus 2 with one singularity. McMullen gives in [McM1] a list of side-length for L-shaped polygons that generate Teichmüller curves. Even more, in [McM2] he shows that every primitive abelian Teichmüller curve generated by a surface of genus 2 with one singularity is generated, up to conjugation, by one of his L-surfaces. The proof in [McM1] is rather algebraic: McMullen shows that his L-surfaces lie in $GL_2^+ \mathbb{R}$ -invariant algebraic subspaces of $\Omega\mathcal{M}_2$, which have complex dimension 2 since they satisfy enough algebraic conditions. This approach makes the computation of the Veech groups difficult; a very detailed treatment of these Teichmüller curves can be found in [Ba], where Bainbridge computes their Euler characteristics.

Unfortunately, McMullen’s approach does not seem to generalize to higher genera: the higher the dimension of the moduli space, the more appropriate conditions one has to find. However, using these ideas, McMullen was able to construct infinite series of primitive Teichmüller curves in genus 3 and 4 and finitely many in genus 5, see [McM3].

Example 5. Identifying opposite sides of a regular $4g$ -gon we obtain a flat surface of genus g with one singularity. A $(4g+2)$ -gon yields a flat surface of the same genus with 2 singularities of equal orders. From [V92] follows that these flat surfaces generate Teichmüller curves; Vorobets computed the corresponding Veech groups in [Vo] to be $\Delta(2g, \infty, \infty)$ ⁹ and $\Delta(2g+1, \infty, \infty)$, respectively.

Example 6. Given a regular n -gon we reflect it on one side to obtain a $2(n-1)$ -gon with parallel opposite sides. Identifying these pairs we obtain a flat surface with one or two singularities. These polygons generate Teichmüller curves by [V92]. By [Vo], the Veech groups are $\Delta(2, n, \infty)$ for odd n , and $\Delta(\frac{n}{2}, \infty, \infty)$ for n even.

⁷The thesis can be downloaded under <http://digbib.ubka.uni-karlsruhe.de/volltexte/documents/2735>, the published version [SchAlg] is reduced to the algorithm.

⁸If S_1 is a torus, one allows the cover to branch over one point only, as square tiled surfaces do.

⁹The triangle group $\Delta(k, l, m)$ with $k, l, m \in \mathbb{N} \cup \{\infty\}$ is the orientation preserving part of the group generated by reflections in \mathbb{H} on sides of a hyperbolic triangle with angles $(\frac{\pi}{k}, \frac{\pi}{l}, \frac{\pi}{m})$. The triangle group is actually a conjugacy class of subgroups in $PSL_2 \mathbb{R}$. The quotient of the upper/lower halfplane by $\Delta(k, l, m)$ is a sphere with 3 special points, where the angles are $\frac{2\pi}{k}$, $\frac{2\pi}{l}$ and $\frac{2\pi}{m}$; in case that k, l , or m is ∞ we obtain a cusp instead of special point.

More generally, given a set of vectors $\{v_1, \dots, v_n\} \subset \mathbb{R}^2$ and a permutation σ on n elements, such that the polygon with consecutive sides $v_1, \dots, v_n, -v_{\sigma(1)}, \dots, -v_{\sigma(n)}$ has no self-intersections, one obtains a very flat surface by identification of corresponding sides. For suitable σ , the vectors $\{v_1, \dots, v_n\}$ build up local complex coordinates for the space of flat surfaces with fixed orders of singularities. This is used e.g. in [Z] to study these spaces.

Another class of examples arises by unfolding rational polygons: Given a euclidean polygon, whose angles are rational multiples of π , there is a canonical way to produce a finite set of congruent polygons by consecutive reflections on sides, which can be glued together to a flat surface, such that the projection to the initial polygon maps geodesics to billiard trajectories, see [KZ] for details. Veech's initial concern was the dynamics of billiards; he proved that the lattice property of the Veech group of the "unfolded" polygon implies optimal dynamics of the billiard: each nonsingular trajectory is either closed or uniformly distributed (for details on the Veech dichotomy see the original paper [V89] or [HuSch]). The converse, however, is not true, see [SW].

Example 7. Unfolding a right triangle with smallest angle $\frac{\pi}{n}$, we obtain a regular n -gon for even n (see Example 5) and two regular n -gons for odd n (see Example 6).

Example 8. An acute isosceles triangle with apex angle $\frac{\pi}{n}$ consists of two copies of a right triangle with angle $\frac{\pi}{2n}$, hence leads to a $2n$ -gon, see Example 5. Unfolding an isosceles triangle with base angle $\frac{\pi}{n}$ leads to Example 7.

Example 9. The only other non-obtuse triangles generating Teichmüller curves have angles $(\frac{\pi}{4}, \frac{\pi}{3}, \frac{5\pi}{12})$, $(\frac{\pi}{5}, \frac{\pi}{3}, \frac{7\pi}{15})$, and $(\frac{2\pi}{9}, \frac{\pi}{3}, \frac{4\pi}{9})$, respectively, as was shown by Kenyon, Smillie und Puchta in [KS] and [P]. The corresponding Veech groups are $\Delta(6, \infty, \infty)$, $\Delta(15, \infty, \infty)$, and $\Delta(9, \infty, \infty)$.

Example 10. For obtuse triangles, such a classification is not known. Besides Example 8, the only infinite series of obtuse triangles generating Teichmüller curves was given by Ward in [W]: an obtuse triangle with angles $(\frac{\pi}{2n}, \frac{\pi}{n}, \frac{(2n-3)\pi}{2n})$ unfolds to a surface with Veech group $\Delta(3, n, \infty)$.

Example 11. Ward's and Veech's examples were generalized in [BM], where Bouw and Möller constructed Teichmüller curves with Veech groups equal to the triangle groups $\Delta(n, m, \infty)$, for almost all $n, m \in \mathbb{N} \cup \infty$. Since Veech groups are never cocompact, these are all possible triangle groups in this context. The authors define a complex bundle of Riemann surfaces with 1-dimensional base B , and prove that the image of the base under the classifying map $B \rightarrow \mathcal{M}_g$ is an image of Teichmüller curve with required properties. The methods are rather algebraic, based on results of [M]. The construction however seems to be inspired by [V89], where Veech gives algebraic equations for his flat surfaces.

For further references concerning triangles (and hence n -gons) consult the summary [Lel]; for the determination of the Veech groups in Examples 5 and 6

see for instance [Lei].

Finally, the last way to construct flat surfaces that we mention here is the so-called Thurston-Veech construction.

A multicurve $\alpha = \{\alpha_1, \dots, \alpha_n\}$ is a collection of distinct isotopy classes of simple closed curves on a topological surface S that can be realized disjointly. A weighted multicurve is a formal sum $\sum_{i=1}^n a_i \alpha_i$, where $\alpha = \{\alpha_1, \dots, \alpha_n\}$ is a multicurve and $a_i \in \mathbb{R}^+$ positive real numbers. Note that the intersection pairing extends linearly from curves to weighted multicurves.

Given two multicurves $\sum_{i=1}^n a_i \alpha_i$ and $\sum_{j=1}^n b_j \beta_j$ on S that fill the surface (i.e. the complementary regions of the union of any isotopy classes' realizations are necessarily topological discs), there is a unique flat structure on S with the following properties:

- the horizontal leaves are compact, and the horizontal cylinders have α_i 's as core curves and heights a_i .
- the vertical leaves are compact, and the vertical cylinders have β_j 's as core curves and heights b_j .

Namely, for each intersection point of α_i and β_j take a rectangle of height a_i and width b_j . Glue two rectangles along vertical sides if they correspond to consecutive intersection points of α_i with β , and along horizontal sides if they correspond to consecutive intersection points of β_j with α . The vertices of the rectangles are then glued together to singularities. For more details on the construction see e.g. Section 5 in [Bo], or [Lei].

Leininger shows in [Lei] that for any filling pair of multicurves α and β , there are appropriate weights such that the horizontal as well as vertical cylinders have modulus¹⁰ μ , where $\mu \in \mathbb{R}$ depends on the intersection configuration of the two multicurves. By the following lemma the Dehn twist around α has an affine representative with derivative $\begin{pmatrix} 1 & \mu \\ 0 & 1 \end{pmatrix}$; analogously, the Dehn twist on β has an affine representative with derivative $\begin{pmatrix} 1 & 0 \\ \mu & 1 \end{pmatrix}$. For $\mu \leq 2$ these two elements generate a lattice in $\mathrm{PSL}_2 \mathbb{R}$, and therefore we obtain examples of Teichmüller curves. However, the examples produced in this way are already mentioned above: for $\mu < 2$ Leininger obtains, up to conjugation, Examples 5, 6 and 9; for $\mu = 2$ we obtain a Veech group that is commensurable to $\mathrm{PSL}_2 \mathbb{Z}$, by [GJ] these Teichmüller curves are generated by origami.

Lemma 3.10. *Let (C, α) and (C', α') be flat cylinders with horizontal boundaries and differential forms non-vanishing in the interior of the cylinders. Let u be the*

¹⁰The modulus of a euclidean cylinder is the ratio of circumference and height, which characterizes the cylinder viewed as Riemann surface. A cylinder of modulus μ is biholomorphic to the region $\left\{ z \in \mathbb{C} \mid e^{-\frac{2\pi}{\mu}} < |z| < 1 \right\}$.

circumference and h the height of C . Let $f : C \rightarrow C'$ be a homeomorphism isometric on the boundary. Let $\tau : [0; 1] \rightarrow C$ be a vertical arc connecting the boundary components of C , let $\int_{f \circ \tau} \alpha' = ah + ibh$. Then the homotopy class $[f]$ (relative ∂C) has an affine representative with derivative $M = \begin{pmatrix} 1 & a \\ 0 & b \end{pmatrix}$. In particular, the Dehn twist $C \rightarrow C$ has an affine representative with derivative $\begin{pmatrix} 1 & \frac{u}{h} \\ 0 & 1 \end{pmatrix}$.

PROOF. Let τ' be the geodesic arc homotopic to $f \circ \tau$ with fixed end points. Then there is a representative of $[f]$ that maps τ affine to τ' . Cutting the cylinders along τ and τ' , we obtain a map from a rectangle to a parallelogram, which is affine on the boundary. Then the homotopy class (relative rectangle's boundary) of this map has a representative that is affine in the interior too. The derivative can be easily computed from the affine representation on the boundary.

In the case of the Dehn twist, the image of the vertical arc τ is homotopic to the composition of τ and the boundary curve γ . Hence, $\int_{f \circ \tau} \alpha = \int_{\tau} \alpha + \int_{\gamma} \alpha = ih + u$, and we compute $a = \frac{u}{h}$ and $b = 1$. \square

Summing up, besides a finite number of examples, the following primitive examples are known:

- the square,
- McMullen's L-surfaces and the series in [McM3],
- the Teichmüller curves with triangular Veech groups in [BM], which include those in [V92] and [W].

4 Cusps of Teichmüller curves

Let j be the Teichmüller disc generated by (X, ω) , let $G := G(X, \omega)$ be its Veech group and $\Gamma := \Gamma(X, \omega)$ be the extended Veech group. We are going to study the cusps of $C := \overline{\mathbb{H}}/\Gamma$. In the case of Teichmüller curves these are the only ends and therefore of great interest; however, this section and the most of the next one apply in the general situation too.

In the last section we have seen that for flat surfaces with horizontal cylindrical decomposition there is a good chance that the Veech group contains a parabolic of the form $\begin{pmatrix} 1 & b \\ 0 & 1 \end{pmatrix}$. In the next lemma we show that the horizontal cylindrical decomposition is necessary:

Lemma 4.1. *Let $M = \begin{pmatrix} 1 & b \\ 0 & 1 \end{pmatrix} \in G$, where $b \neq 0$ is a real number. Then (X, ω) decomposes into horizontal cylinders, and their moduli are commensurable¹¹.*

PROOF. Let $\phi \in \text{Aff}(X, \omega) = \Gamma$ be an affine diffeomorphism with derivative M . Then ϕ permutes singularities of (X, ω) . Taking a sufficiently high power of ϕ we can assume that ϕ fixes each singularity. Analogously we can assume ϕ to fix each horizontal half-leaf starting in the singularities. From the matrix $\text{Der}(\phi) = M = \begin{pmatrix} 1 & b \\ 0 & 1 \end{pmatrix}$ we deduce that ϕ fixes these half-leaves pointwise.

Assume that one of them does not run into a singularity, in particular it is not closed. Let $l : \mathbb{R}_{\geq 0} \rightarrow X$ be the parametrisation of this leaf with unit speed. Let $p \in X$ be a nonsingular limit point of $\{l(n) | n \in \mathbb{N}\}$; if every limit point of this set is singular, we pass to a limit point of $\{l(n + \varepsilon) | n \in \mathbb{N}\}$ for some small $\varepsilon \in \mathbb{R}$. Let $N(p) \subset X$ be a small neighborhood of p , and $z : N(p) \rightarrow \mathbb{R}^2$ be a ω -natural coordinate with $z(p) = 0$. Since p is fixed under ϕ as a limit point of fixed points, the representation of ϕ in the coordinate z is linear, namely, multiplication by M . On the other hand, the image of $l(\mathbb{R}_{\geq 0}) \cap N(p)$ under z is a collection of infinitely many horizontal intervals, since the leaf is not closed. These horizontal intervals consist of fixed points of ϕ , hence $M = \begin{pmatrix} 1 & 0 \\ 0 & 1 \end{pmatrix}$, which contradicts the assumption.

By the discussion at the end of Section 2 we obtain a horizontal cylindrical decomposition of (X, ω) . Let C_1, \dots, C_k be these cylinders and let μ_i be the modulus of C_i . Since ϕ is the identity on the boundaries, it must be a power of the Dehn twist in the interior of each cylinder. The Dehn twist on C_i has an affine representation with derivative $\begin{pmatrix} 1 & \mu_i \\ 0 & 1 \end{pmatrix}$ by Lemma 3.10, and we conclude that b is a common multiple of the μ_i 's, hence the moduli are commensurable. \square

A subgroup $G' \subset \text{PSL}_2 \mathbb{R}$ is parabolic iff the elements of G' share an eigenvector with eigenvalue ± 1 . Let $G' \subset G$ be a parabolic subgroup of the Veech group of (X, ω) . Let A be a matrix mapping the eigenvector of G' to some horizontal vector. Then we can apply the previous lemma to the surface $A(X, \omega)$, whose Veech group is AGA^{-1} . We deduce the cylindrical decomposition of (X, ω) in the direction of the eigenvector of G' ; the commensurability of moduli is preserved by $\text{id}_A : X \rightarrow AX$. Conversely, it is easy to see that each direction on (X, ω) that yields a cylindrical decomposition with commensurable moduli is fixed under a cyclic subgroup. Hence, parabolic subgroups of G correspond to directions with cylindrical decompositions and commensurable moduli.

Up to a change of the generator of the Teichmüller disc, which corresponds to precomposition of a Möbius transformation to j and conjugation of the

¹¹Real numbers are commensurable if they generate a discrete additive subgroup of \mathbb{R} , which is cyclic then.

Veech group, we can assume the parabolic subgroup G' to contain $\begin{pmatrix} 1 & 1 \\ 0 & 1 \end{pmatrix}$. From the Jørgensen inequality we deduce the following property of the horodisc $H := \{w \in \overline{\mathbb{H}} \mid \text{Im } w < -1\}$: For any $M \in G$ we have either $\mu_M(H) \cap H = \emptyset$ or $\mu_M(H) = H$. Denote by Γ' the preimage of G' under $\Gamma \xrightarrow{\text{Der}} G$. Then the open suborbifold $H/\Gamma' \subset \overline{\mathbb{H}}/\Gamma$ is what we call a cusp. We call (the conjugacy class of) Γ' the fundamental group of the cusp, and denote it by $\pi_1(\text{cusp})$. It contains a normal subgroup $\pi_1^0(\text{cusp})$ consisting of multiple Dehn twists in the cylinders; these are precisely the affine diffeomorphisms that are identity on the union of singular leaves in the corresponding direction. Note that Der is injective on $\pi_1^0(\text{cusp})$, since Dehn twists are not holomorphic.

5 Universal curve over a cusp

In this section we will construct a cover of the universal curve over a compactified cusp of a Teichmüller curve. In the first step we construct a bundle of noded surfaces over a disc D , with additional structure; and in the second step we show that the fibers have complex structures corresponding to points in the image of the cusp in \mathcal{M}_g . By the universal property of the compactified moduli space we obtain a morphism $D \rightarrow \overline{\mathcal{M}}_g$, whose image compactifies the cusp. As a corollary, we will be able to compute the intersection number of the cusp with the compactification divisor.

The idea on which this section is based is illustrated in the following figure. Namely, let X be a flat surface. Then opening the nodes of a suitable noded surface X_0 with suitable parameters gives a surface that can be obtained by applying a matrix to the initial surface X . The reader should keep this simple figure in mind while reading the technical constructions.

5.1 Surface bundle over a disc

Let (X, ω) be a flat surface generating a Teichmüller curve as in the previous section; X decomposes into horizontal cylinders C_1, \dots, C_k . Let $\gamma_i : \mathbb{S}^1 \rightarrow X$ be the core curve in the middle of C_i , i.e. running around the cylinder through points equidistant to the both boundary components. Cut X along every γ_i to obtain X_{cut} , a surface with $2k$ boundary components $\gamma_i^+, \gamma_i^-, i = 1, \dots, k$.

Denote by $C_i^+ \subset X_{\text{cut}}$ the half of C_i bounded by γ_i^+ , and define C_i^- analogously. Let u_i be the circumference and h_i be the height of C_i and let $\mu_i = \frac{u_i}{h_i}$ be the modulus of C_i . Via ω -natural charts C_i is biholomorphic to a rectangle in \mathbb{C} of height h_i and width u_i with the vertical sides identified by translation. We can assume that the center of the rectangle coincides with $0 \in \mathbb{C}$ and obtain a new chart for C_i by applying the map $z \mapsto e^{\frac{2\pi i}{u_i} z}$. The new model for C_i is the ring region $\left\{ z \in \mathbb{C} \mid e^{-\frac{\pi}{\mu_i}} < |z| < e^{\frac{\pi}{\mu_i}} \right\}$.

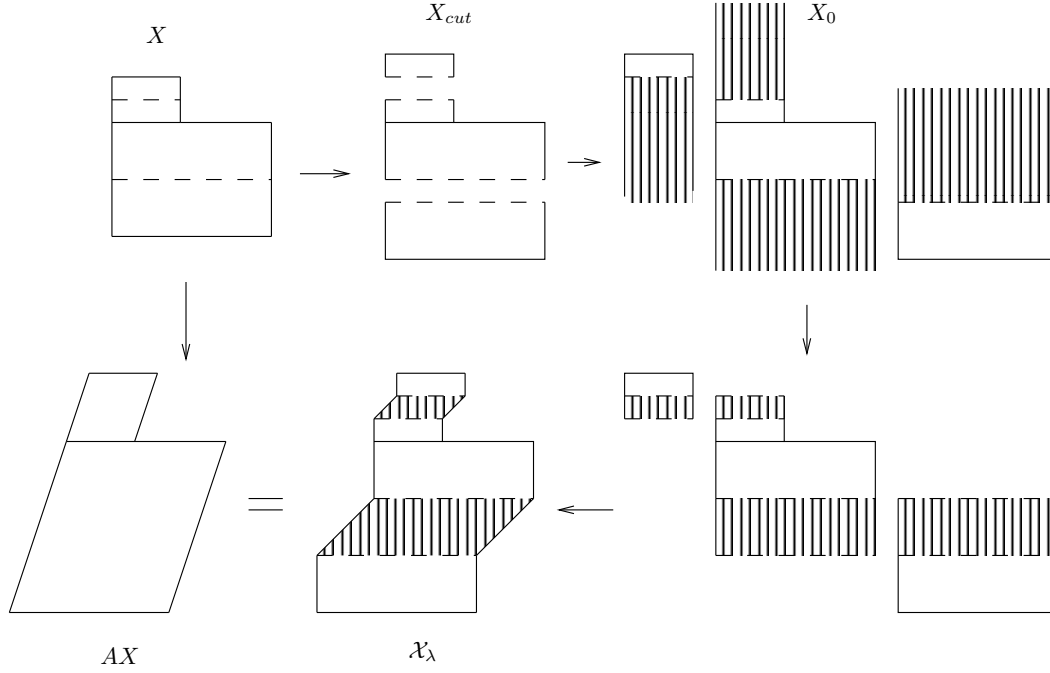

In the new model, ω equals $(\frac{u_i}{2\pi i} \frac{dz}{z})^2$. For instance, the horizontal foliation maps to the foliation by concentric circles, the vertical one maps to the radial foliation. The image of γ_i is the unit circle, without loss of generality we can assume it to be parametrized by $\mathbb{R}/\mathbb{Z} \rightarrow \mathbb{C}$, $t \mapsto e^{2\pi i t}$. We can also assume that the C_i^+ get mapped to the inner region $\{z \in \mathbb{C} | e^{-\frac{\pi}{\mu_i}} < |z| \leq 1\}$ and C_i^- to the outer region $\{z \in \mathbb{C} | 1 \leq |z| < e^{\frac{\pi}{\mu_i}}\}$. Using these models for $C_i^{+/-}$ we attach punctured discs

- $D_i^- = \{z \in \mathbb{C} | 0 < |z| < 1\}$ to C_i^- ,
- $D_i^+ = \{z \in \mathbb{C} | 1 < |z|\}$ to C_i^+ .

We obtain a noded surface X_0 ; by continuation of $\omega(z) = (\frac{u_i}{2\pi i} \frac{dz}{z})^2$ we obtain a quadratic differential ω_0 on X_0 . Note that if we start the construction with a differential form α , we obtain a holomorphic differential α_0 .

In the following we construct a family of flat surfaces over the unit disc $D = \{z \in \mathbb{C} | |z| < 1\}$. Let μ be the least common multiple of μ_i , $i = 1, \dots, k$, set $n_i := \frac{\mu}{\mu_i}$, for $\lambda \in D$ let $\lambda_i := \lambda^{n_i}$.

We start with $X_0 \times D$. Delete the regions $\{(z, \lambda) \in D_i^- \times D | |z| \leq |\lambda_i|\}$ and $\{(z, \lambda) \in D_i^+ \times D | |z| \geq \frac{1}{|\lambda_i|}\}$ for all i . Denote by \mathcal{R} the remaining part of $X_0 \times D$, which is a 2-dimensional complex manifold consisting of $X_{cut} \times D$ and the parts

$R_i^- := \{(z, \lambda) \in D_i^- \times D \mid |z| > |\lambda_i|\}$ and $R_i^+ := \{(z, \lambda) \in D_i^+ \times D \mid |z| < \frac{1}{|\lambda_i|}\}$ for $i = 1, \dots, k$. Set $\dot{R}_i^- := \{(z, \lambda) \in R_i^- \mid \lambda \neq 0\}$ and $\dot{R}_i^+ := \{(z, \lambda) \in R_i^+ \mid \lambda \neq 0\}$.

Identify \dot{R}_i^+ and \dot{R}_i^- via the holomorphic map $f_i : \dot{R}_i^+ \rightarrow \dot{R}_i^-$, $(z, \lambda) \mapsto (z\lambda_i, \lambda)$. We want to show that the space $\mathcal{X} = \mathcal{R}/(f_1, \dots, f_k)$ is Hausdorff. For this, we need only to consider pairs of points $(z_1, 0) \in R_i^+$ and $(z_2, 0) \in R_i^-$; for other pairs the Hausdorff condition is obviously fulfilled. Let $(z_1 + \varepsilon, \delta)$ be a point close to $(z_1, 0)$; then $f_i : (z_1 + \varepsilon, \delta) \mapsto ((z_1 + \varepsilon)\delta^{n_i}, \delta) \in R_i^-$, whose first coordinate tends to zero as $\delta \rightarrow 0$. Hence, the image of a small neighborhood of $(z_1, 0)$ under f_i does not intersect a small neighborhood of $(z_2, 0)$. Thus \mathcal{X} is Hausdorff.

We have constructed a complex 2-manifold \mathcal{X} consisting of $X_{cut} \times D$ and $R_i := (R_i^+ \cup R_i^-)/f_i$, $i = 1, \dots, k$. Note that the ‘‘bundle structure map’’ $\mathcal{X} \rightarrow D$ is well defined, hence we obtain a family of Riemann surfaces, which are compact except the fiber over $0 \in D$, which is X_0 .

We have a holomorphic section in (the square of) the *relative cotangent bundle* of $X_0 \times D \rightarrow D$, which is α_0 (or ω_0 , resp.) on each fiber. In R_i^\pm it is given by the (square of) $(\frac{u_i}{2\pi i} \frac{dz}{z})$. From the following computation we deduce its invariance under f_i :

$$\left(f_i^* \left(\frac{dz}{z} \right) \right) |_{(z_0, \lambda)} (\partial z) = \frac{dz}{z} |_{(z_0 \lambda_i, \lambda)} (\lambda_i \partial z) = \frac{1}{z_0} = \frac{dz}{z} |_{(z_0, \lambda)} (\partial z)$$

Consequently, we obtain a holomorphic section \mathcal{A} in (the square of) the relative cotangent bundle of $\mathcal{X} \rightarrow D$.

Remark. The zeros of \mathcal{A} are precisely $(\text{zeros of } \omega) \times D \subset X_{cut} \subset \mathcal{X}$, with corresponding multiplicities.

5.2 The fibers of the surface bundle

Let \mathcal{X}_λ denote the fiber of $\mathcal{X} \rightarrow D$ over λ , let \mathcal{A}_λ be the restriction of \mathcal{A} to \mathcal{X}_λ . Before we prove the central Proposition 5.2, let us recall how we construct \mathcal{X}_λ out of X . First, we cut along curves γ_i and attach discs D_i^\pm to obtain X_0 . Then we cut off parts of D_i^\pm , and identify their remains by f_i . Summing up, we inserted a cylinder for each γ_i , see the previous figure.

Let $\pi : N \rightarrow \overline{\mathcal{M}}_g$ be a coordinate neighborhood of the point in $\overline{\mathcal{M}}_g$ corresponding to X_0 , with respect to the attached discs D_i^- and D_i^+ , $i = 1, \dots, k$. The map identifying the remain of D_i^\pm is $z \mapsto \lambda_i z$, hence, we obtain \mathcal{X}_λ by opening the nodes of X_0 with coordinates $(\lambda_1, \dots, \lambda_k) = (\lambda^{n_1}, \dots, \lambda^{n_k})$, where $n_i \mu_i = \mu$. We record the following fact:

Fact 5.1. Let $c : D \rightarrow \overline{\mathcal{M}}_g$ be the classifying map of \mathcal{X} . Then c factors through $D \rightarrow N$, $\lambda \mapsto (\lambda^{n_1}, \dots, \lambda^{n_k}, 0, \dots, 0)$, which is injective since n_i 's have no common divisor.

The next proposition brings us back to $\text{GL}_2^+ \mathbb{R}$ -actions:

Proposition 5.2. *Let $\lambda \in D$, $\lambda \neq 0$. Let ϕ and r be real numbers such that $\lambda = e^{2\pi i\phi+r}$ and let $A = \begin{pmatrix} 1 & \phi\mu \\ 0 & 1 - \frac{r\mu}{2\pi} \end{pmatrix}$. Then $(\mathcal{X}_\lambda, \mathcal{A}_\lambda) \cong A(X, \omega)$.*

PROOF. Note that X_{cut} is isometrically imbedded in $(\mathcal{X}_\lambda, \mathcal{A}_\lambda)$. Hence, we consider C_i^\pm and γ_i^\pm as cylinders and curves in \mathcal{X}_λ . Recall the parametrization of γ_i^\pm by $\mathbb{R}/\mathbb{Z} \rightarrow D_i^\pm$, $t \mapsto e^{2\pi it}$.

Let $Z_i \subset \mathcal{X}_\lambda$ denote the i -th inserted cylinder, which is bounded by γ_i^\pm . Let ρ_i be the image of the arc $[0, 1] \rightarrow D_i^-$, $s \mapsto e^{(2\pi i\phi+r)n_i s}$ in \mathcal{X}_λ . This arc in D_i^- connects $1 = \gamma_i^-(0)$ to $\lambda_i = \lambda^{n_i}$, the last point is the image of $\gamma_i^+(0)$ under the identification $f_i : z \mapsto \lambda_i z$. Hence, ρ_i connects $\gamma_i^-(0)$ to $\gamma_i^+(0)$ in \mathcal{X}_λ .

We define ρ_i^t to be the image of the arc $[0, 1] \rightarrow D_i^-$, $s \mapsto e^{(2\pi i\phi+r)n_i s + 2\pi it}$ in \mathcal{X}_λ . Analogously, it connects $\gamma_i^-(t)$ to $\gamma_i^+(t)$. Moreover, Z_i is swept out by these disjoint arcs, hence, we can homotopy the inclusion $X_{cut} \rightarrow \mathcal{X}_\lambda$ to a homeomorphism $f : X \rightarrow \mathcal{X}_\lambda$ by ‘‘pulling’’ γ_i^- to γ_i^+ along ρ_i^t for each i . This homeomorphism is isometric on the union of horizontal saddle connections, which we denote by K . Let τ_i be the vertical arc connecting boundaries in $C_i \subset X$, intersecting γ_i in $\gamma_i(0)$. In X_{cut} , τ_i decomposes into τ_i^- in C_i^- and τ_i^+ in C_i^+ . From the construction of f we conclude that the arc $f \circ \tau_i$ is homotopic to the composition of the arcs τ_i^- , $\rho_i = \rho_i^0$ and τ_i^+ .

We are now able to apply Lemma 3.10 to each C_i ; note that in the interior of each horizontal cylinder there exists a square root of ω , therefore we can assume to deal with differential forms rather than with quadratic differentials; we choose the orientation such that τ_i is running in the positive vertical direction. For the following computation, recall that the pullback of \mathcal{A}_λ to D_i^\pm is $\frac{u_i}{2\pi i} \frac{dz}{z}$, and $\mu = n_i \mu_i$ is the least common multiple of the moduli $\mu_i = \frac{u_i}{h_i}$.

$$\begin{aligned} \int_{f \circ \tau_i} \mathcal{A}_\lambda &= \int_{\tau_i^-} \mathcal{A}_\lambda + \int_{\rho_i} \mathcal{A}_\lambda + \int_{\tau_i^+} \mathcal{A}_\lambda = ih_i + \int_0^1 \frac{u_i}{2\pi i} \frac{(2\pi i\phi+r)n_i e^{(2\pi i\phi+r)n_i s} ds}{e^{(2\pi i\phi+r)n_i s}} = \\ &= ih_i + \frac{u_i(2\pi i\phi+r)n_i}{2\pi i} = ih_i + u_i n_i \phi - i \frac{n_i u_i r}{2\pi} = \\ &= \mu_i n_i \phi \cdot h_i + i \left(1 - \frac{\mu_i n_i r}{2\pi}\right) \cdot h_i = \mu \phi \cdot h_i + i \left(1 - \frac{\mu r}{2\pi}\right) \cdot h_i \end{aligned}$$

By Lemma 3.10, in each C_i , f is homotopic relative boundary to an affine map with derivative $A = \begin{pmatrix} 1 & a \\ 0 & b \end{pmatrix}$ with $a = \phi\mu$ and $b = 1 - \frac{r\mu}{2\pi}$. The composition of these homotopies is affine with the same derivative. Then $\mathcal{X}_\lambda \xrightarrow{id_{\mathcal{A}} \circ f^{-1}} AX$ has derivative $\pm \mathbb{1}$, hence is an isomorphism of flat surfaces. \square

Corollary 5.3. *Let $c : D \rightarrow \overline{\mathcal{M}}_g$ be the classifying map of \mathcal{X} . Let $H := \{w \in \overline{\mathbb{H}} \mid \text{Im } w < -1\}$ be the horoball mapped to the cusp of Teichmüller curve*

generated by (X, ω) . Let $p : H \rightarrow \dot{D}$, $w \mapsto e^{-\frac{2\pi i}{\mu}w + \frac{2\pi}{\mu}}$, where $\dot{D} = D \setminus \{0\}$. Then there exists a unique morphism $\dot{D} \rightarrow \text{cusp}$ such that the following diagram commutes. The morphism $\dot{D} \rightarrow \text{cusp}$ is a cover of degree $\left| \frac{\pi_1(\text{cusp})}{\pi_1^0(\text{cusp})} \right|$ and extends to $D \rightarrow \overline{\text{cusp}}$ with the same properties.

$$\begin{array}{ccc}
 \mathcal{T}_g & \xleftarrow{j} & \overline{\mathbb{H}} \supset H \\
 \downarrow \pi & & \downarrow \\
 \mathcal{M}_g & \xleftarrow{j} & \text{cusp}
 \end{array}
 \quad
 \begin{array}{ccc}
 & & \dot{D} \\
 & \swarrow p & \\
 \dot{D} & & \\
 \swarrow c & & \searrow \\
 \mathcal{M}_g & & \text{cusp}
 \end{array}$$

PROOF. Let $w = -\phi\mu - i(1 - \frac{r\mu}{2\pi}) \in H$. Then A_w is the matrix A in Proposition 5.2, thus $\pi(j(w)) = A_w X = [\mathcal{X}_\lambda]$, where $[\mathcal{X}_\lambda]$ denotes the isomorphism class of \mathcal{X}_λ , which is a point in \mathcal{M}_g . On the other hand, $c(p(-\phi\mu - i(1 - \frac{r\mu}{2\pi}))) = c(e^{2\pi i\phi + r}) = c(\lambda) = [\mathcal{X}_\lambda]$, hence, the upper left triangle commutes.

For the definition of $\dot{D} \rightarrow \text{cusp}$ note that the deck transformations of $H \rightarrow \dot{D}$ build up the group generated by the Möbius transformation of $\begin{pmatrix} 1 & \mu \\ 0 & 1 \end{pmatrix}$, hence coincides with the image of $\pi_1^0(\text{cusp})$ in $\text{PSL}_2 \mathbb{R}$. Since Der is injective on $\pi_1^0(\text{cusp})$, we deduce $\dot{D} = H/\pi_1^0(\text{cusp})$, and obtain a unique morphism $\dot{D} \rightarrow \text{cusp} = H/\pi_1(\text{cusp})$, which is a cover of the right order. This morphism makes the right triangle in the diagram commute.

Since the big rectangle commutes, the last bit of the diagram, the lower triangle, commutes too.

Recall that we constructed $\overline{\mathcal{C}}$ by means of manifold covers of $\overline{\mathcal{M}}_g$. Combining the lower triangle in the diagram with the Fact 5.1, and taking into account that N is a manifold, hence a coordinate for $\overline{\mathcal{M}}_g$, we deduce that the topological extension of $\dot{D} \rightarrow \text{cusp}$ into 0 is an orbifold morphism. \square

We have proved the following (vaguely formulated) theorem:

Theorem 5.4. *In suitable coordinates, the imbedding of the compactified cusp of a Teichmüller curve in $\overline{\mathcal{M}}_g$ is $D \rightarrow N \subset \mathbb{C}^{3g-3}$, $\lambda \mapsto (\lambda^{n_1}, \dots, \lambda^{n_k}, 0, \dots, 0)$. The divisor $\mathcal{D} = \overline{\mathcal{M}}_g \setminus \mathcal{M}_g$ is defined in N by the equation $z_1 z_2 \cdots z_k = 0$. In particular, a Teichmüller curve intersects the compactification divisor normally.*

5.3 Intersection with the compactification divisor

Theorem 5.4 allows us to compute the intersection number of \mathcal{D} with the cusp, and consequently, with the Teichmüller curve. By intersection number we mean,

as usual, the evaluation of the cohomology class defined by \mathcal{D} on the homology class defined the Teichmüller curve $j : \overline{C} \rightarrow \overline{\mathcal{M}}_g$. In order to avoid interpretation of intersection numbers on an orbifold, we pass to manifold covers.

Let $\pi : \overline{\mathcal{L}}_g \rightarrow \overline{\mathcal{M}}_g$ be a finite normal manifold cover, with covering group G . Let $j : \overline{V} \rightarrow \overline{\mathcal{L}}_g$ be the preimage of \overline{C} in the sense of fiber products. Then the following diagram commutes. Moreover, \overline{V} inherits a G -action from $\overline{\mathcal{L}}_g$, such that the diagram is compatible with both G -actions, and $\overline{V}/G = \overline{C}$.

$$\begin{array}{ccc} \overline{V} & \xrightarrow{j} & \overline{\mathcal{L}}_g \\ \downarrow & j & \downarrow \pi \\ \overline{C} & \xrightarrow{j} & \overline{\mathcal{M}}_g \end{array}$$

Note that some elements of G may act by identity on \overline{V} . Since $\overline{\mathcal{L}}_g$ is a manifold, so is \overline{V} . Let $[\overline{V}]$ be the fundamental class of \overline{V} , and $j_*[\overline{V}]$ be its image in $H_2(\overline{\mathcal{L}}_g, \mathbb{Q})$. Then $|G|j_*[\overline{C}] = \pi_*j_*[\overline{V}] \in H_2(\overline{\mathcal{M}}_g, \mathbb{Q})$ by definition of the fundamental class of orbifolds, see Section 1.1. We denote by $\mathcal{D} \in H^2(\overline{\mathcal{M}}_g, \mathbb{Q})$ the cohomology class of the compactification divisor. Then $|G|(\mathcal{D}, j_*[\overline{C}]) = (\pi^*\mathcal{D}, j_*[\overline{V}])$, and it suffices to compute the last, which is a usual intersection number on a manifold. Here, we need to sum up the intuitive intersection numbers of all intersection points.

Let $D \rightarrow N$ be as in the Fact 5.1. Since $\overline{\mathcal{L}}_g \rightarrow \overline{\mathcal{M}}_g$ is a manifold cover, there is an injective lift of $N \rightarrow \overline{\mathcal{M}}_g$ to $\overline{\mathcal{L}}_g$. By the definition of \overline{V} as fiber product and Corollary 5.3, $D \rightarrow N \rightarrow \overline{\mathcal{L}}_g$ factors through \overline{V} such that the following diagram commutes:

$$\begin{array}{ccccc} & & \overbrace{\hspace{10em}} & & \\ D & \longrightarrow & \overline{V} & \xrightarrow{j} & \overline{\mathcal{L}}_g & \longleftarrow & N \\ & \searrow & \downarrow & & \downarrow \pi & & \swarrow \\ & & \overline{C} & \xrightarrow{j} & \overline{\mathcal{M}}_g & & \end{array}$$

The preimage of the filled cusp of C in \overline{V} consists of some copies of the image of D in \overline{V} , each contributing $\sum n_i$ to $(\pi^*\mathcal{D}, j_*[\overline{V}])$. G acts transitively on the set of these copies; let $m := \left| \frac{\pi_1(\text{cusp})}{\pi_1^0(\text{cusp})} \right|$ denote the order of the cover $D \rightarrow \overline{\text{cusp}}$, then there are $\frac{|G|}{m}$ copies of D in \overline{V} . Thus the cusp in C contributes $\frac{|G|}{m} \sum n_i$ to $(\pi^*\mathcal{D}, j_*[\overline{V}])$, and, as a consequence, contributes $\frac{1}{m} \sum n_i$ to $(\mathcal{D}, j_*[\overline{C}])$. We have proved the following theorem.

Theorem 5.5. *For a cusp of a Teichmüller curve $j : C \rightarrow \mathcal{M}_g$, let $\pi_1(\text{cusp})$ and $\pi_1^0(\text{cusp})$ be as in Section 4. Let $n_i, i = 1, \dots, k$ be the commensurability numbers*

of the moduli of the cylinders in the decomposition corresponding to the cusp.

$$\text{Then } (\mathcal{D}, j_*[\overline{C}]) = \sum_{\text{cusps}} \frac{\sum n_i}{\left| \frac{\pi_1(\text{cusp})}{\pi_1^0(\text{cusp})} \right|}.$$

In the case of abelian Teichmüller curves, every γ_i is non-separating. Namely, we can distinguish between right and left boundaries of C_i 's, and in the critical graph they are glued together by right \rightarrow left. A separating γ_i would cut X into two subsurfaces; in one of them (containing the left boundary of C_i) the total length of left boundaries is greater than the length of the right boundaries, and in the other subsurface vice versa. Hence, an abelian Teichmüller curve intersects only the \mathcal{D}_0 component of \mathcal{D} . We conclude $(\mathcal{D}_i, j_*[\overline{C}]) = 0$ for $i > 0$ and $(\mathcal{D}_0, j_*[\overline{C}]) = (\mathcal{D}, j_*[\overline{C}])$.

Remark. The common definition of a Teichmüller curve differs slightly from ours. Namely, let $G(X, \omega)$ be the Veech group of (X, ω) . The term “Teichmüller curve generated by (X, ω) ” usually means the (image of the) immersion $\overline{\mathbb{H}}/G(X, \omega) \rightarrow \mathcal{M}_g$. This definition takes care of isolated special points, ignoring the trivial action of $\text{Aut}(X, \omega)$ on $\overline{\mathbb{H}}$. The homology class arising via this definition is $|\text{Aut}(X, \omega)| j_*[\overline{C}]$, and the intersection number is the $|\text{Aut}(X, \omega)|$ -multiple of our intersection number. For more details see the Section 6.4.

5.4 Examples

In some known cases that arise “algebraically”, like McMullen’s L-surfaces, the computation of the intersection number using the theorem is quite hard. Indeed, for L-surfaces even the computation of the number of cusps is a task on its own. In “constructive” examples, however, the theorem can be applied. We illustrate the result by application to the Teichmüller curves defined by regular n -gons, as in Section 3.5.

Example 1. In the surface obtained from a regular $(4g + 2)$ -gon by gluing opposite sides, we have the two cylindrical decompositions shown in the following figure. In the first we have g cylinders, each of modulus $2 \cot \alpha$. An affine diffeomorphism $\phi \in \pi_1(\text{cusp})$ preserves the unique shortest horizontal saddle connection s , which is the horizontal side of the polygon. Then ϕ is either identity on s , or ϕ rotates s around its center by angle π , which is the hyperelliptic involution.

In the first case, ϕ fixes the endpoints of s , which are the only singularities. Since ϕ is orientation preserving, it respects the cyclic order of the horizontal leaves starting in each singularity. Since s is fixed, ϕ preserves each horizontal saddle connection, hence $\phi \in \pi_1^0(\text{cusp})$. If ϕ rotates s , then the composition of ϕ with the hyperelliptic involution fixes the endpoints of $s \Rightarrow \left| \frac{\pi_1(\text{cusp})}{\pi_1^0(\text{cusp})} \right| = 2$.

In the second cylindrical decomposition we have $g + 1$ cylinders, g of which have modulus $2 \cot \alpha$, whereas the modulus of the middle cylinder is $\cot \alpha$. Let ϕ be in $\pi_1^0(\text{cusp})$, we want to show that, up to composition with the hyperelliptic

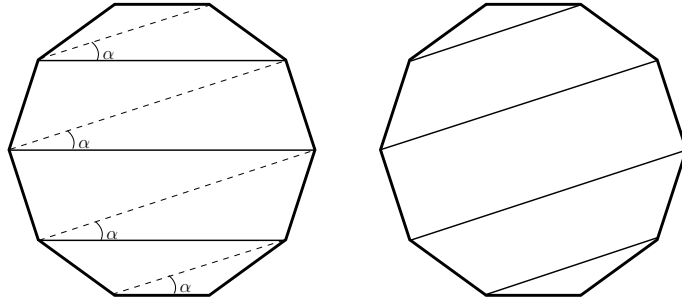

involution, ϕ is identity on the singular leaves. From this we deduce $\left| \frac{\pi_1(\text{cusp})}{\pi_1^0(\text{cusp})} \right| = 2$ again.

Since the hyperelliptic involution interchanges the both singularities, we can assume ϕ to fix them. Since ϕ permutes the $g + 1$ cylinders preserving the circumferences, and the circumference of the middle cylinder is unique, we conclude that ϕ preserves the middle cylinder. Different boundary components of this cylinder contain different singularities, thus, they are preserved too. We give the boundary curves an orientation, which is preserved by ϕ , since ϕ respects the orientation of the cylinder, and preserves boundary components. The restriction of ϕ to each boundary component of the cylinder is an orientation preserving isometry with a fixed point, hence, the identity. Now we observe that every other cylinder is preserved too, since the circumferences are unique, and apply the same arguments to them; alternatively we can apply the argument using cyclic order of singular leaves at a singularity.

These two decompositions define different cusps, since the numbers of cylinders differ. By [Vo] the Veech group is $\Delta(2g + 1, \infty, \infty)$, hence these are the only cusps. We conclude $(\mathcal{D}, j_*[\overline{C}]) = \frac{g}{2} + \frac{g+2}{2} = g + 1$.

Example 2. In a regular $4g$ -gon we see the following decompositions:

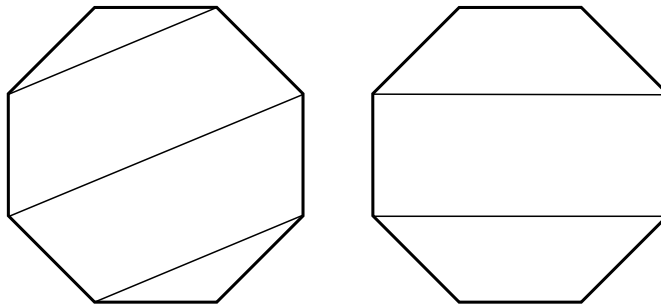

The first decomposition has g cylinders with equal moduli; the second has g cylinders, all but the middle one having equal moduli, and the middle cylinder's modulus is the half of the other moduli. Analogously to the previous example, we compute $\left| \frac{\pi_1(\text{cusp})}{\pi_1^0(\text{cusp})} \right| = 2$ for both cusps. Again, by [Vo], these decompositions

define the only two cusps of the Teichmüller curve, and we conclude $(\mathcal{D}, j_*[\overline{C}]) = \frac{g}{2} + \frac{g+1}{2} = \frac{2g+1}{2}$.

Example 3. Consider now two $(2g+1)$ -gons as in the following figure. We identify the opposite sides in the resulting $4g$ -gon.

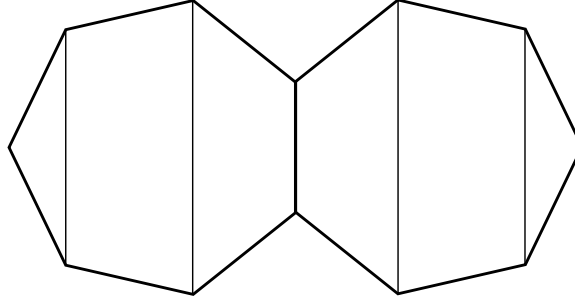

By [Vo] the corresponding Teichmüller curve has one cusp, which corresponds e.g. to the vertical decomposition. We see g cylinder with equal moduli, and $\left| \frac{\pi_1(\text{cusp})}{\pi_1^0(\text{cusp})} \right| = 2$ by the same arguments. Thus $(\mathcal{D}, j_*[\overline{C}]) = \frac{g}{2}$.

Example 4. The last example concerning regular polygons is the Teichmüller curve generated by the union of two $(2g+2)$ -gons. We identify the opposite sides in the constructed $(4g+2)$ -gon, as in the previous example. The two cusps ([Vo]) correspond to the following decompositions:

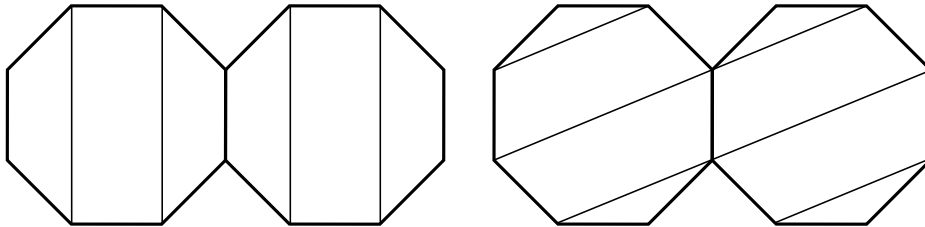

The first decomposition has g cylinders of equal moduli; the second has $g+1$ cylinders of equal moduli. The automorphism group $\text{Aut}(X, \omega)$ is generated by two elements: the rotation by π around the center of the vertical segment in the middle, which is the hyperelliptic involution, and the rotation of each $(2g+2)$ -gon by π around its center. One shows easily $\text{Aut}(X, \omega) \cong \mathbb{Z}/2 \times \mathbb{Z}/2$. Using the same arguments with longest/shortest saddle connection, one shows $\frac{\pi_1(\text{cusp})}{\pi_1^0(\text{cusp})} \cong \text{Aut}(X, \omega)$ for both cusps. We deduce $(\mathcal{D}, j_*[\overline{C}]) = \frac{g}{4} + \frac{g+1}{4} = \frac{2g+1}{4}$.

Example 5. Finally, we give an example with $\frac{\pi_1(\text{cusp})}{\pi_1^0(\text{cusp})} \not\cong \text{Aut}(X, \omega)$. By [HeSch], the Veech group of the “Wollmilchsau” (see Figure 6) is $\text{PSL}_2(\mathbb{Z})$, hence we need to consider only one cusp. The moduli of horizontal cylinders in Figure 6 are both 4, however the image of the fundamental group of the cusp in $\text{PSL}_2 \mathbb{R}$ is

generated by $\begin{pmatrix} 1 & 1 \\ 0 & 1 \end{pmatrix}$ and not by $\begin{pmatrix} 1 & 4 \\ 0 & 1 \end{pmatrix}$, which is the derivative of the Dehn twist

in the horizontal cylinders. More precisely, $\left| \frac{\pi_1(\text{cusp})}{\pi_1(\text{cusp})} \right| = |\text{Aut}(X, \omega)| \left| \frac{\left\langle \begin{pmatrix} 1 & 1 \\ 0 & 1 \end{pmatrix} \right\rangle}{\left\langle \begin{pmatrix} 1 & 4 \\ 0 & 1 \end{pmatrix} \right\rangle} \right|$,

which is $16 \cdot 4 = 64$ by [HeSch]. We compute $(\mathcal{D}, j_*[\overline{C}]) = \frac{2}{64} = \frac{1}{32}$.

6 Evaluation of κ_1 on abelian Teichmüller curves

In this section we evaluate the first Mumford-Morita class on the homology class defined by an abelian Teichmüller curve. Let (X, α) generate $j : C \rightarrow \mathcal{M}_g$.

To avoid dealing with orbifolds, we pass to finite manifold covers. Let $V, \overline{V}, \overline{\mathcal{L}}_g, D \rightarrow \overline{V} \rightarrow \overline{\mathcal{L}}_g$ be as in Section 5.3. Let $\mathcal{L}_g \rightarrow \overline{\mathcal{L}}_g$ be the preimage of \mathcal{M}_g in $\overline{\mathcal{M}}_g$, and $V \rightarrow \mathcal{L}_g$ be the preimage of C in \mathcal{L}_g . Let G be the covering group of $\overline{\mathcal{L}}_g \rightarrow \overline{\mathcal{M}}_g$, and hence, of any other cover mentioned. Let $X \rightarrow \overline{\mathcal{M}}_g$ be an orbifold morphism. Denote by \mathcal{C}_X the pullback of the universal curve $C \rightarrow \overline{\mathcal{M}}_g$ to X , call it the universal curve over X ; if X is a manifold, then \mathcal{C}_X is a noded surface bundle in the manifold sense. Recall the definition of the line bundle $\mathcal{B} \rightarrow C$, whose square is isomorphic to the cotangent bundle of C via $J : T^*\mathbb{H} \rightarrow \mathcal{B} \otimes \mathcal{B} \subset T^*\mathcal{T}_g = \Omega^2\mathcal{T}_g$, $A \bullet (-i, dw) \mapsto A(X, \alpha^2)$. Let \mathcal{B}_V be the pullback of $\mathcal{B} \rightarrow C$ to V .

6.1 Holomorphic section in \mathcal{B} and its zeros

Recall that for abelian Teichmüller curves, $(\mathcal{X}, \mathcal{A})$ is a bundle of Riemann surfaces with holomorphic forms on them. By the Proposition 5.2 \mathcal{A} defines a non-vanishing section in the restriction of \mathcal{B}_V to the cusp \dot{D} of V by $\mathcal{A}|_{\dot{D}} : \dot{D} \rightarrow \mathcal{B}$, $\lambda \mapsto (\mathcal{X}_\lambda, \mathcal{A}_\lambda)$. We use this to extend the line bundle $\mathcal{B}_V \rightarrow V$ to $\mathcal{B}_{V \cup D} \rightarrow V \cup D$ as follows:

- $\Gamma(U, \mathcal{B}_{V \cup D}) = \Gamma(U, \mathcal{B}_V)$ for $U \subset V$,
- $\Gamma(D, \mathcal{B}_{V \cup D}) = \mathcal{O}(D) \cdot \mathcal{A}$

Extending \mathcal{B}_V to every cusp of \overline{V} in this way, we obtain a line bundle $\mathcal{B}_{\overline{V}} \rightarrow \overline{V}$. Note that although $\mathcal{B}_V \otimes \mathcal{B}_V \cong T^*V$, the analogue for $\mathcal{B}_{\overline{V}}$ does not need to be true; in fact, it is wrong, as we will see very soon.

Let σ be a global meromorphic section in $\mathcal{B}_{\overline{V}}$, with no zero or pole in the cusps of \overline{V} , i.e. $\sigma|_D = \phi \cdot \mathcal{A}$ with $\phi(0) \neq 0, \infty$. By choosing a smaller D we can assume that ϕ has no zeros or poles in D .

For the the computation of the number of zeros of σ we first extend $\mathcal{A}|_{\dot{D}} \otimes \mathcal{A}|_{\dot{D}}$, which is a section in $\mathcal{B}_{\dot{D}}^2 \cong T^*\dot{D}$, to T^*D . We can assume to be in the context

of Proposition 5.2. Let H be the horoball in $\overline{\mathbb{H}}$, which is a component of the preimage of the cusp, as in section 4.

Consider the section $H \rightarrow T^*H$, $w \mapsto (w, \frac{1}{2i}dw)$. By Lemmas 3.1 and 3.7, under the identification $\mathcal{B}_H^2 \cong T^*H$ it corresponds to $H \rightarrow \mathcal{B}^2$, $w \mapsto A_w(X, \alpha^2)$. Under $p : H \rightarrow \dot{D}$ from the Corollary 5.3 this projects to the section $\dot{D} \rightarrow \mathcal{B}_{|\dot{D}}^2$, $\lambda \mapsto (\mathcal{X}_\lambda, \mathcal{A}_\lambda \otimes \mathcal{A}_\lambda)$.

Recall that $p(w) = e^{\frac{2\pi i}{\mu}w - \frac{2\pi}{\mu}} = \lambda$. Under this projection the section $H \rightarrow T^*H$, $w \mapsto (w, \frac{1}{2i}dw)$ projects to $\dot{D} \rightarrow T^*\dot{D}$, $\lambda \mapsto \frac{1}{2i} \frac{d\lambda}{p'(w)} = \frac{1}{2i} \frac{d\lambda}{\frac{-2\pi i}{\mu} p(w)} = \frac{\mu}{4\pi} \frac{d\lambda}{\lambda}$, whose extension to $D \rightarrow T^*D$ has a single pole in 0.

Then $\sigma|_V \otimes \sigma|_V$ corresponds to a section $V \rightarrow T^*V$, that extends to a section $\overline{V} \rightarrow T^*\overline{V}$ with simple poles in the cusps. This extension has $-\chi(V)$ zeros outside the cusps. By isomorphism $\mathcal{B}_V \otimes \mathcal{B}_V \cong T^*V$, $\sigma \otimes \sigma$ has the same number of zeros. We conclude that σ has $-\frac{\chi(V)}{2}$ zeros. In particular, we can assume σ to be holomorphic.

6.2 Holomorphic section in the cotangent bundle of the universal curve

On the other hand, σ defines a holomorphic section Σ in the relative cotangent bundle of the universal curve over \overline{V} , since it assigns a holomorphic form to each fiber, depending holomorphically on the basepoint¹². Σ has two types of zeros:

- The fibers over zeros of σ are zeros of Σ with the same multiplicity. We call these components vertical.
- Let $x \in V$ and (X', α') be a very flat surface in the fiber \mathcal{B}_x . Then any other surface in the fiber is $(X', \lambda\alpha')$ for some $\lambda \in \mathbb{C}$. Hence, the zeros of the differential in the fiber \mathcal{C}_x do not depend on the particular choice of $\sigma(x) \in \mathcal{B}_x$, assuming $\sigma(x) \neq 0$. These zeros build up the so-called horizontal components. The horizontal components of the zero divisor of Σ have the same multiplicities as the corresponding zeros on the fibers.

Let N be the horizontal zero divisor of Σ . Over V the projection $\text{supp}(N) \rightarrow \overline{V}$ is easily seen to be a local homeomorphism; over the cusps it is by the remark at the end of Section 5.1. Hence, the support of N , which is a submanifold of $\mathcal{C}_{\overline{V}}$, is an unbranched cover of \overline{V} . Let N_k denote the (not necessarily connected) component of $\text{supp}(N)$ consisting of zeros of the order k . The degree of the cover $N_k \rightarrow \overline{V}$ coincides with the number of zeros of order k , which we denote by a_k . Thus we obtain $N = \sum kN_k$ and the relation $2g - 2 = \sum a_k k$.

¹²Recall that by the discussion in Section 1.2, the nodes are “very removable” singularities, so that the definition of such a section outside the nodes is sufficient.

6.3 Evaluation of κ_1 on \overline{V} and on \overline{C}

Recall the definition of κ_1 . Let $T_{\mathcal{C}/\overline{\mathcal{M}}_g}$ be the relative tangent bundle of the universal curve $\mathcal{C} \rightarrow \overline{\mathcal{M}}_g$, which is a line bundle on \mathcal{C} . Let $e \in H^2(\mathcal{C}, \mathbb{Q})$ be its Chern class. Then $\kappa_1 \in H^2(\overline{V}, \mathbb{Q})$ is the image of e^2 under the Gysin morphism. Then $(\kappa_1, j_*[\overline{V}]) = (e^2, j_*[\mathcal{C}_{\overline{V}}])$, where $j^{\mathcal{C}} : \mathcal{C}_{\overline{V}} \rightarrow \mathcal{C}$ is the preimage of $j : \overline{V} \rightarrow \overline{\mathcal{L}}_g \rightarrow \overline{\mathcal{M}}_g$ in \mathcal{C} .

Let $e_{\overline{V}} := (j^{\mathcal{C}})^*(e) \in H^2(\mathcal{C}_{\overline{V}}, \mathbb{Q})$, then $e_{\overline{V}}$ is the Chern class of the relative tangent bundle of $\mathcal{C}_{\overline{V}} \rightarrow \overline{V}$, which we denote by $T_{\mathcal{C}/\overline{V}}$. Then $(\kappa_1, j_*[\overline{V}]) = (e_{\overline{V}}^2, [\mathcal{C}_{\overline{V}}])$, which we will compute in two steps. First, we compute $(e_{\overline{V}}, [\mathcal{C}_{\overline{V}}]) \in H_2(\mathcal{C}_{\overline{V}}, \mathbb{Q})$ as a divisor in \mathcal{C} and then evaluate the Chern class of the restriction of $T_{\mathcal{C}/\overline{V}}$ to the divisor.

Observe that Σ as in Section 6.2. is a section in the relative cotangent bundle, hence, its zero divisor is $-(e_{\overline{V}}, [\mathcal{C}_{\overline{V}}])$. For the first part of the evaluation, we obtain $(e_{\overline{V}}, [\mathcal{C}_{\overline{V}}]) = -\sum_{k=1}^{2g-2} k[N_k] - \sum [\mathcal{C}_{x_i}]$, where the second sum is taken over $-\frac{\chi(V)}{2}$ zeros of σ . Now we need to compute $(e_{\overline{V}}, [\mathcal{C}_{x_i}])$ as well as $(e_{\overline{V}}, [N_k])$.

For the vertical components, we simply note that the restriction of $T_{\mathcal{C}/\overline{V}}$ to \mathcal{C}_{x_i} is by definition the tangent bundle of \mathcal{C}_{x_i} . Since $x_i \in V$, the fibers are surfaces of genus g and we obtain $(e_{\overline{V}}, [\mathcal{C}_{x_i}]) = \chi(\mathcal{C}_{x_i}) = 2 - 2g$.

In the horizontal case, we need more care and a technical observation. A point in the line bundle $\mathcal{B}_{\overline{V}} \rightarrow \overline{V}$ corresponds to a pair (complex structure, holomorphic form); the projection “forgets” the form. Note that the forms in a fiber differ only by multiplication with complex numbers. Let N_k be a connected component of the zero divisor in $\mathcal{C}_{\overline{V}}$ as above, consider $\mathcal{B}_{N_k} \rightarrow N_k$, the pullback of $\mathcal{B}_{\overline{V}} \rightarrow \overline{V}$ via the cover $N_k \rightarrow \overline{V}$. In other words, a point in \mathcal{B}_{N_k} corresponds to the triple (complex structure, holomorphic differential form (which is a complex multiple of some fixed form), zero of the differential form of order k), and the projection forgets the form, remembering the zero.

Consider $T_{N_k} \rightarrow N_k$, the restriction of the universal curve’s relative tangent bundle $T_{\mathcal{C}/\overline{V}} \rightarrow \mathcal{C}_{\overline{V}}$ to $N_k \subset \mathcal{C}$. A point in this bundle corresponds to (complex structure, zero of some fixed form, tangent vector with base point in the zero), the projection forgets the tangent vector. The two bundles over N_k are not dual, however we can define a kind of pairing, which enables us to compare their Chern classes. We will need the following lemma:

Lemma 6.1. *Let U, V be line bundles over a Riemann surface S such that there exists a “pairing” $\langle \cdot, \cdot \rangle : U \times V \rightarrow \mathbb{C} \times S$ with $\langle \lambda u, v \rangle = \lambda \langle u, v \rangle$ and $\langle u, \lambda v \rangle = \lambda^l \langle u, v \rangle$ for $\lambda \in \mathbb{C}$. Then U and $V^{\otimes l}$ are dual.*

PROOF. We define a bundle morphism $m : U \otimes V^{\otimes l} \rightarrow \mathbb{C} \times S$ to the trivial bundle fiberwise. Let $v_1 \otimes \dots \otimes v_l \in V_s^{\otimes l}$, then there exists $v \in V_s$ such that $v_1 \otimes \dots \otimes v_l = v \otimes \dots \otimes v$. We set $m(u \otimes v_1 \otimes \dots \otimes v_l) = \langle u, v \rangle$. We first note that we have l choices for v , which differ by multiplication with l -th roots of unity. Since the “pairing” is l -homogeneous in the second argument, the particular choice does not

matter. To show that m is well-defined we have to prove $m((\lambda u) \otimes v_1 \otimes \dots \otimes v_l) = m(u \otimes \lambda(v_1 \otimes \dots \otimes v_l))$ and equality of this to $\lambda m(u \otimes v_1 \otimes \dots \otimes v_l)$ for the linearity of m .

From the linearity of the “pairing” in the first argument we conclude $m((\lambda u) \otimes v_1 \otimes \dots \otimes v_l) = m((\lambda u) \otimes v \otimes \dots \otimes v) = \langle \lambda u, v \rangle = \lambda \langle u, v \rangle$. Let $\lambda^{\frac{1}{l}}$ be any l -th root of λ . Then $\lambda(v_1 \otimes \dots \otimes v_l) = \lambda(v \otimes \dots \otimes v) = (\lambda^{\frac{1}{l}} v) \otimes \dots \otimes (\lambda^{\frac{1}{l}} v)$, and hence $m(u \otimes \lambda(v_1 \otimes \dots \otimes v_l)) = \langle u, \lambda^{\frac{1}{l}} v \rangle = \lambda \langle u, v \rangle$. \square

Let v be a non-zero tangent vector on a Riemann surface X , with base point x , and α a holomorphic form on X having a zero of order k in x . Let $\varepsilon > 0$ be such that the ε -neighborhood of x in X with respect to the singular euclidean metric defined by α is a disc containing no singularities other than x . Let $v(\varepsilon)$ be the point at distance ε from x on the line of constant direction tangent to v . We define $\langle \alpha, v \rangle := \frac{|v|^{k+1}}{\varepsilon} \int_x^{v(\varepsilon)} \alpha$, where $|v|$ is the hyperbolic length. As one can see immediately, this notion is independent of ε and hence well-defined. The “pairing” is \mathbb{C} -linear in the first argument, which we let vary over the complex multiples of α . We let the second argument vary over $T_x X$, which are complex multiples of v . Then one can show that the “pairing” is $(k+1)$ -homogeneous in the second argument by integrating in a coordinate such that $\alpha = z^k dz$.

We denote the first Chern class of a line bundle $A \rightarrow X$ on a Riemann surface X by $c(A)$. Now we can apply the previous lemma to $\mathcal{B}_{N_k} \rightarrow N_k$ and $T_{N_k} \rightarrow N_k$ to obtain $c(\mathcal{B}_{N_k}) = -(k+1)c(T_{N_k}) \Rightarrow (c(\mathcal{B}_{N_k}), [N_k]) = -(k+1)(c(T_{N_k}), [N_k]) = -(k+1)(e_{\overline{V}}, [N_k])$. On the other hand, in the computation of the number of zeros of σ we have seen that $(c(\mathcal{B}_{\overline{V}} \otimes \mathcal{B}_{\overline{V}}), [\overline{V}]) = -\chi(V)$, and hence $2(c(\mathcal{B}_{N_k}), [N_k]) = (c(\mathcal{B}_{N_k} \otimes \mathcal{B}_{N_k}), [N_k]) = -a_k \chi(V)$, since $N_k \rightarrow \overline{V}$ is a cover of degree a_k . Combining, we obtain $-2(k+1)(e_{\overline{V}}, [N_k]) = -a_k \chi(V) \Rightarrow (e_{\overline{V}}, [N_k]) = \frac{a_k \chi(V)}{2(k+1)}$.

Now we are ready to complete our evaluation:

Proposition 6.2. *For $k = 1, \dots, 2g - 2$ let a_k be the number of zeros of order k in (X, α) . Then $(\kappa_1, j_*[\overline{V}]) = \chi(V) \left(1 - g - \sum_{k=1}^{2g-2} \frac{ka_k}{2(k+1)}\right)$.*

PROOF. $(\kappa_1, j_*[\overline{V}]) = (e^2, [\mathcal{C}]) = (e, (e, [\mathcal{C}])) = (e, -\sum_k k[N_k] - \sum_i [\mathcal{C}_{x_i}]) = -\sum_k k(e, [N_k]) - \sum_i (e, [\mathcal{C}_{x_i}]) = -\sum_k k \frac{a_k \chi(V)}{2(k+1)} - (2-2g)\left(-\frac{\chi(V)}{2}\right) = \chi(V) \left(1 - g - \sum_k \frac{a_k k}{2(k+1)}\right)$ \square

Let G be the covering group of $\overline{\mathcal{L}}_g \rightarrow \overline{\mathcal{M}}_g$, and hence, of $V \rightarrow C$. Then, by the definitions, $\chi(V) = |G|\chi(C)$ and $(\kappa_1, j_*[\overline{V}]) = (\kappa_1, j_*(|G|[\overline{C}])) = |G|(\kappa_1, j_*[\overline{C}])$. We deduce the same expression for the evaluation of $\kappa_1 \in H^2(\overline{\mathcal{M}}_g, \mathbb{Q})$ on the compactified Teichmüller curve instead of \overline{V} , with the orbifold Euler characteristic.

Theorem 6.3. *Let $C \rightarrow \mathcal{M}_g$ be an abelian Teichmüller curve generated by a differential form with a_k zeros of order k , for $k = 1, \dots, 2g - 2$, let $j : \overline{C} \rightarrow \overline{\mathcal{M}}_g$ be the compactification. Then $(\kappa_1, j_*[\overline{C}]) = \chi(C) \left(1 - g - \sum_{k=1}^{2g-2} \frac{ka_k}{2(k+1)}\right)$. In*

particular, it is positive and depends only on the orbifold Euler characteristic of C and the combinatorics of zeros of the generating form.

Example. If the generating differential has one zero of order $2g-2$, we obtain $a_{2g-2} = 1$ and $a_k = 0$ for $k \neq 2g-2$, hence $(\kappa_1, j_*[\overline{C}]) = \chi(C) \left(1 - g - \frac{2g-2}{4g-2}\right) = \chi(C) \frac{2g(1-g)}{2g-1}$.

Example. If the generating differential has $2g-2$ simple zeros, we obtain $a_1 = 2g-2$ and $a_k = 0$ for $k \neq 1$, hence $(\kappa_1, j_*[\overline{C}]) = \chi(C) \left(1 - g - \frac{2g-2}{4}\right) = \chi(C) \frac{1-g}{2}$.

Since $\frac{n}{n+1} + \frac{m}{m+1} \geq \frac{n+m}{n+m+1}$ for $n, m \in \mathbb{N}$, the two examples are extreme.

Corollary 6.4. Let $g \geq 2$ and let $c_1(g) = \frac{g-1}{2}$, $c_2(g) = \frac{2g(g-1)}{2g-1}$. Then the following inequality holds for an abelian Teichmüller curve $j : \overline{C} \rightarrow \mathcal{M}_g$:

$$-c_1(g)\chi(C) \leq (\kappa_1, j_*[\overline{C}]) \leq -c_2(g)\chi(C)$$

6.4 Weil-Petersson vs. Teichmüller area

As an application of our result, we compare the Teichmüller and Weil-Petersson areas of abelian Teichmüller curves. Here the following, more common definition of a Teichmüller curve, which we mentioned in the remark at the end of Section 5.3, is useful. Let $j : C \rightarrow \mathcal{M}_g$ be an abelian Teichmüller curve defined by (X, α^2) , let $G(X, \alpha^2)$ be the Veech group of (X, α^2) , which is the image of the extended Veech group $\Gamma(X, \alpha^2) = \text{Aff}(X, \alpha^2)$ in $\text{PSL}_2 \mathbb{R}$. Recall that the kernel of $\text{Aff}(X, \alpha^2) \rightarrow G(X, \alpha^2)$ is the automorphism group $\text{Aut}(X, \alpha^2)$. Then $j_w : \overline{\mathbb{H}}/G(X, \alpha^2) =: C_w \rightarrow \mathcal{M}_g$ is the object usually called the Teichmüller curve. Observe that $\text{Aut}(X, \alpha^2)$ acts trivially on C_w and $C_w/\text{Aut}(X, \alpha^2) = C$, moreover $j_w = j \circ pr$ with the cover $pr : C_w \rightarrow C$ of degree $|\text{Aut}(X, \alpha^2)|$. Note also that $[C_w] = |\text{Aut}(X, \alpha^2)|[C]$ and $\chi(C_w) = |\text{Aut}(X, \alpha^2)|\chi(C)$, hence Theorem 6.3 is valid with C_w instead of C and j_w instead of j . Since the restrictions of metrics to subspaces do not notice trivial actions, this is the right setting to work in.

Since $j : \overline{\mathbb{H}} \rightarrow \mathcal{T}_g$ is an isometry with respect to Poincaré and Teichmüller metrics, we can easily compute the Teichmüller area of the Teichmüller curve to be the hyperbolic area of C_w , which is $-2\pi\chi(C_w)$. Note that the Gauss-Bonnet theorem is valid for C_w , as one shows by passing to a finite manifold cover.

In [Wo85] Wolpert constructs a current $\omega_{WP}^{\mathbb{C}}$ that extends the Weil-Petersson Kähler form to $\overline{\mathcal{M}}_g$. In [Wo83] he shows that $\omega_{WP}^{\mathbb{C}}$ is closed and defines a class in $H^2(\overline{\mathcal{M}}_g, \mathbb{R})$, which equals $2\pi^2\kappa_1$.

Let $j : \overline{V} \rightarrow \overline{\mathcal{L}}_g$ be as above. Since j is a holomorphic immersion of manifolds, the evaluation of κ_1 , and hence of $\omega_{WP}^{\mathbb{C}}$, on \overline{V} provides the Weil-Petersson area of V^{13} . Since the cover $V \rightarrow C$ is *topologically* of degree $\frac{|G|}{|\text{Aut}(X, \alpha^2)|}$,

¹³Although the current $\omega_{WP}^{\mathbb{C}}$ is singular on the compactification divisor, the computation of

we deduce $\text{area}_{WP}(C) = \frac{|\text{Aut}(X, \alpha^2)|}{|G|} \text{area}_{WP}(V) = \frac{|\text{Aut}(X, \alpha^2)|}{|G|} (\kappa_1, j_*[\bar{V}]) = \text{Aut}(X, \alpha^2)(\kappa_1, j_*[\bar{C}]) = (\kappa_1, j_{w*}[C_w])$. Using Theorem 6.3 we obtain:

Corollary 6.5. Let $j : C \rightarrow \mathcal{M}_g$ be an abelian Teichmüller curve, generated by a differential form α with a_k zeros of order k , for $k = 1, \dots, 2g - 2$. Let $c_1(g) = \frac{g-1}{2}$, $c_2(g) = \frac{2g(g-1)}{2g-1}$. Then the following holds:

- $\text{area}_{WP}(C) = 2\pi^2 \chi(C_w) \left(1 - g - \sum_{k=1}^{2g-2} \frac{ka_k}{2(k+1)}\right)$
 $= 2\pi \text{area}_{TM}(C) \left(g - 1 + \sum_{k=1}^{2g-2} \frac{ka_k}{2(k+1)}\right),$
- $-2\pi^2 c_1(g) \chi(C_w) \leq \text{area}_{WP}(C) \leq -2\pi^2 c_2(g) \chi(C_w),$
- $\frac{\text{area}_{WP}(C)}{\text{area}_{TM}(C)} = \pi \left(g - 1 + \sum_{k=1}^{2g-2} \frac{ka_k}{2(k+1)}\right),$
- $\pi c_1(g) \leq \frac{\text{area}_{WP}(C)}{\text{area}_{TM}(C)} \leq \pi c_2(g).$

6.5 Examples

It is easy to apply the results to the flat surfaces with known Veech groups and automorphism groups, as for the examples in the Section 5.4. In the following we give explicit results for Example 3 in Section 5.4. For L-surfaces, see [Ba] for the computation of Euler characteristics.

Let (X, ω) be the flat surface of genus g obtained from the union of two $(2g + 1)$ -gons. This surface has only one singularity. In Section 5.4 we have seen that $\text{Aut}(X, \omega)$ has order 2, the only nontrivial element being the hyperelliptic involution. Let $C \xrightarrow{j} \mathcal{M}_g$ be the Teichmüller curve generated by (X, ω) . The Veech group of (X, ω) equals $\Delta(2, 2g + 1, \infty)$ by [Vo].

From the Veech group we deduce the hyperbolic area of C_w , which is the Teichmüller area of C , to be $2(\pi - \frac{\pi}{2} - \frac{\pi}{2g+1}) = 2\pi \frac{2g-1}{4g+2}$. Applying the Gauss-Bonnet theorem we obtain $\chi(C_w) = -\frac{2g-1}{4g+2}$. From this follows $\chi(C) = \frac{\chi(C_w)}{|\text{Aut}(X, \omega)|} = -\frac{2g-1}{8g+4}$. The bracket term in Theorem 6.3 equals $-c_2(g) = -\frac{2g(g-1)}{2g-1}$. Hence, we obtain the following results:

- $(\kappa_1, j_*[\bar{C}]) = \frac{2g-1}{8g+4} \cdot \frac{2g(g-1)}{2g-1} = \frac{g(g-1)}{4g+2},$
- $\text{area}_{WP}(C) = 2\pi^2 \frac{2g-1}{4g+2} \cdot \frac{2g(g-1)}{2g-1} = 2\pi^2 \frac{g(g-1)}{2g+1},$
- $\text{area}_{TM}(C) = 2\pi \frac{2g-1}{4g+2},$
- $\frac{\text{area}_{WP}(C)}{\text{area}_{TM}(C)} = \pi \frac{2g(g-1)}{2g-1} = \pi c_2(g).$

the area works, since a Teichmüller curve intersects the divisor *normally*. For details consult [Wo85].

References

- [Ab] Abikoff, W., *Topics in the real analytic theory of Teichmüller spaces*, Springer Lecture Notes in Mathematics **820**, Springer-Verlag, New York (1980).
- [Ba] Bainbridge, M., *Euler characteristics of Teichmüller curves in genus two*, *Geom. Topol.* **11** (2007), 1887-2073.
- [BM] Bouw, I., Möller, M., *Teichmüller curve, triangle groups, and Lyapunov exponents*, to appear in *Ann. Math.*
- [Bo] Bowditch, B.H., *Intersection numbers and the hyperbolicity of the curve complex*, *J. reine angew. Math.* **598** (2006), 105-129.
- [GJ] Gutkin, E., Judge, C., *Affine mappings of translation surfaces: geometry and arithmetic*, *Duke Math. J.* **103** (2000), 191-213.
- [HeSch] Herrlich, F., Schmithüsen, G., *An extraordinary origami curve*, *Math. Nachrichten.* **281.2** (2008), 219-237.
- [H] Hubbard, J.H., *Teichmüller Theory and Applications to Geometry, Topology, and Dynamics. Volume 1: Teichmüller Theory*, Matrix Editions, Ithaca, NY (2006).
- [HuSch] Hubert, P., Schmidt, Th., *An introduction to Veech surfaces*, Ch. 6 in: "Handbook of Dynamical Systems, Vol.1B" (edited by Hasselblatt, Katok), Elsevier (2006) 501-526.
- [KZ] Katok, A., Zemlyakov, A., *Topological transitivity of billiards in polygons*, *Math. Notes* **18** (1975) 760-764.
- [KS] Kenyon, R., Smillie, J., *Billiards in rational-angled triangles*, *Comment. Mathem. Helv.* **75** (2000), 65-108.
- [Lei] Leininger, Ch., *On groups generated by two positive multi-twists: Teichmüller curves and Lehmer's number*, *Geom. Topol.* **8** (2004), 1301-1359.
- [Lel] Lelievre, S., *Veech surfaces associated with rational billiards.*, arXiv, math.GT/0205249
- [Lo] Looijenga, E., *Smooth Deligne-Mumford compactifications by means of Prym levels structures*, *J. Alg. Geom.* **3** (1994), 283-293.
- [M] Möller, M., *Variations of Hodge structure of Teichmüller curves*, *Journal of the AMS* **19** (2006), 327-344.

- [McM1] McMullen, C., *Billiards and Teichmüller curves on Hilbert modular surfaces*, J. Amer. Math. Soc. **16** (2003), 857-885.
- [McM2] McMullen, C., *Teichmüller curves in genus 2: Discriminant and spin*, Math. Ann. **333** (2005), 87-130.
- [McM3] McMullen, C., *Prym varieties and Teichmüller curves*, Duke Math. J. **133** (2006), 569-590.
- [P] Puchta, J.-Ch., *On triangular billiards*, Comment. Mathem. Helv. **76** (2001), 501-505.
- [SchTh] Schmithüsen, G., *Veech Groups of Origamis*, Dissertation Karlsruhe (2005).
- [SchAlg] Schmithüsen, G., *An algorithm for finding the Veech group of an origami*, Experimental Mathematics **13.4** (2004), 459-472.
- [SW] Smillie, J., Weiss, B., *Veech's dichotomy and the lattice property*, to appear in Ergod. Th. and Dyn. Systems.
- [V89] Veech, W., *Teichmüller curves in modular space, Einstein series, and an application to triangular billiards*, Inv. Math. **97** (1989), 553-583.
- [V92] Veech, W., *The billiard in a regular polygon*, Geom. Func. Anal. **2** (1992), 341-379.
- [V95] Veech, W., *Geometric realizations of hyperelliptic curves*, in "Algorithms, Fractals and Dynamics" (edited by Takahashi, Y.) Plenum Publishing, New York (1995), 217-226.
- [Vo] Vorobets, Ya. B., *Planar structures and billiards in rational polygons: the Veech alternative*, Russ. Math. Surv. **51** (1996), 779-817.
- [W] Ward, C., *Calculation of Fuchsian groups associated to billiards in a rational triangle*, Ergod. Th. and Dyn. Systems **18** (1998), 1019-1042.
- [Wo85] Wolpert, S.A., *On the Weil-Petersson geometry of the moduli space of curves*, Amer. J. Math. **107(4)** (1985), 969-997.
- [Wo83] Wolpert, S.A., *On the homology of the moduli space of curves*, Annals of Math. **118** (1983), 491-523.
- [Z] Zorich, A., *Flat surfaces*, in "Frontiers in Number Theory, Physics and Geometry. Volume 1: On random matrices, zeta functions and dynamical systems" (edited by Cartier, P., Julia, B., Moussa, P., Vanhove, P.), Springer-Verlag, Berlin (2006), 439-586.

Zusammenfassung

Teichmüllerkurven in der Deligne-Mumford-Kompaktifizierung

Der Gegenstand der vorliegenden Arbeit sind Teichmüllerkurven. Diese sind spezielle komplex eindimensionale Unterorbifaltigkeiten von \mathcal{M}_g , dem Modulraum geschlossener Riemannscher Flächen vom Geschlecht $g \geq 2$. Genauer, es wird ihre Lage in der Deligne-Mumford-Kompaktifizierung $\overline{\mathcal{M}}_g$ des Modulraums untersucht, indem der Schnitt des Kompaktifizierungsddivisors $\mathcal{D} = \overline{\mathcal{M}}_g \setminus \mathcal{M}_g$ mit einer Teichmüllerkurve in geeigneten Koordinaten dargestellt wird. Unter Ausnutzung dieser Darstellung wird die Schnittzahl berechnet. Im Falle der abelschen Teichmüllerkurven wird die erste Mumford-Morita Kohomologiekategorie κ_1 auf der durch die kompaktifizierte Teichmüllerkurve definierten Homologiekategorie ausgewertet. Einerseits vervollständigt dies die homologische Untersuchung der abelschen Teichmüllerkurven, da κ_1 zusammen mit den Komponenten von \mathcal{D} die zweite Kohomologieguppe von $\overline{\mathcal{M}}_g$ mit Koeffizienten in \mathbb{Q} frei erzeugt. Andererseits erlaubt die letzte Auswertung eine Berechnung der Weil-Petersson Fläche der abelschen Teichmüllerkurven.

Bis auf den Abschnitt 1, in dem die grundlegenden Eigenschaften und Strukturen der Orbifaltigkeiten sowie der Modulräume erklärt bzw. zitiert sind, ist die Arbeit eine im Wesentlichen in sich geschlossene, auch wenn bei weitem nicht vollständige Darstellung des Forschungsbereichs: naturgemäß werden viele Aspekte der umfangreichen Theorie der Teichmüllerkurven nicht berücksichtigt. Das primäre Ziel dieser Arbeit ist ein strenger Beweis der eigenen Ergebnisse, der eine ebenso strenge Einführung in das Gebiet erfordert. Diese umfasst Abschnitte 2 bis 4 und stellt eine wohlbekannt Sachlage vor; in den letzten beiden Abschnitten werden dagegen neue Ergebnisse präsentiert.

Ausgehend von einem holomorphen quadratischen Differential ω auf einer Riemannschen Fläche, definieren wir im zweiten Abschnitt ω -natürliche Karten. Diese bilden einen Atlas für das Komplement der Nullstellen von ω , so dass die Kartenwechselabbildungen \pm -Translationen sind. Mittels dieses Atlas definieren wir eine Euklidische Metrik auf dem Komplement der Nullstellen, deren Fortsetzung auf die gesamte Fläche konische Singularitäten in den Nullstellen hat. Das Paar (Riemannsche Fläche, holomorphes quadratisches Differential) heißt flache Fläche. Die Gruppe $GL_2^+ \mathbb{R}$ wirkt auf dem Raum der flachen Flächen wie folgt. Indem wir eine Matrix A , als Selbstabbildung von $\mathbb{R}^2 = \mathbb{C}$, den natürlichen Karten einer flachen Fläche hintererschalten, erhalten wir den natürlichen Atlas einer neuen flachen Fläche. Wir bringen im Abschnitt 3 diese Wirkung in Verbindung mit der Wirkung von $GL_2^+ \mathbb{R}$ auf dem Kotangentialbündel der unteren Halbebene $\overline{\mathbb{H}}$ durch Pullbacks der Möbius-Transformationen. Dadurch er-

halten wir, ausgehend von einer flachen Fläche (X, ω) , eine Abbildung von $T^*\overline{\mathbb{H}}$ in den Raum der markierten flachen Flächen, der mit dem Kotangentenbündel des Teichmüllerraums \mathcal{T}_g kanonisch identifiziert ist. Diese Abbildung steigt zu einer Einbettung, genannt Teichmüllerscheibe, $\overline{\mathbb{H}} \rightarrow \mathcal{T}_g$ ab, von der wir zeigen, dass sie holomorph und isometrisch bezüglich der Teichmüllermetrik ist. Das Bild einer Teichmüllerscheibe sind alle komplexen Strukturen, die durch die Wirkung von $GL_2^+ \mathbb{R}$ aus (X, ω) entstehen können. Die Abbildungsklassengruppe Map_g operiert auf dem Teichmüllerraum durch holomorphe Isometrien. Die Elemente von Map_g , die das Bild der von (X, ω) erzeugten Teichmüllerscheibe erhalten, bilden die Untergruppe $\Gamma(X, \omega)$, die wir erweiterte Veechgruppe nennen. Wir erhalten eine holomorphe Abbildung von $\overline{\mathbb{H}}/\Gamma(X, \omega)$ in den Modulraum \mathcal{M}_g . Falls $\Gamma(X, \omega)$ durch ein Gitter auf $\overline{\mathbb{H}}$ wirkt, nennen wir die letzte Abbildung eine Teichmüllerkurve. Das Gitter enthält immer parabolische Elemente, und im Abschnitt 4 untersuchen wir die parabolischen Enden von $C := \overline{\mathbb{H}}/\Gamma(X, \omega)$. Wir stellen fest, dass ein solches Ende zu einer Zerlegung der flachen Fläche in Euklidische Zylinder mit geodätischem Rand und kommensurablen Moduli korrespondiert.

Im Abschnitt 5 konstruieren wir ein Bündel flacher Flächen über einer Scheibe D mit folgenden Eigenschaften. Einerseits sind alle bis auf eine Faser Flächen, die aus (X, ω) durch Wirkung von $GL_2^+ \mathbb{R}$ entstehen. Die Ausnahmefaser X_0 ist eine Fläche mit paarweise angeordneten Spitzen und korrespondiert daher zu einem Punkt $[X_0]$ in der Deligne-Mamford-Kompaktifizierung $\overline{\mathcal{M}}_g$. Das Bild der Bündelbasis D in $\overline{\mathcal{M}}_g$ besteht also aus Punkten im Bild der Teichmüllerkurve und $[X_0]$, mit anderen Worten, das Bild von D ist das Bild einer kompaktifizierten Spitze von C . Andererseits lässt sich aus der Konstruktion des Bündels leicht eine Karte $N \rightarrow \overline{\mathcal{M}}_g$ angeben, deren Bild $[X_0]$ enthält und in der der Kompaktifizierungsdivisor und die Abbildung $D \rightarrow N$ einfache Darstellung haben. Wir erhalten das folgende Ergebnis:

Theorem 5.4. *Die kompaktifizierte Spitze einer Teichmüllerkurve hat in geeigneten Koordinaten die Darstellung $D \rightarrow N \subset \mathbb{C}^{3g-3}$, $\lambda \mapsto (\lambda^{n_1}, \dots, \lambda^{n_k}, 0, \dots, 0)$. Dabei sind die Zahlen $n_1, \dots, n_k \in \mathbb{N}$ die Kommutabilitätszahlen der Moduli der Zylinder in der Zerlegung von (X, ω) , die zur Spitze korrespondiert. Der Divisor $\mathcal{D} = \overline{\mathcal{M}}_g \setminus \mathcal{M}_g$ ist in N durch die Gleichung $z_1 z_2 \cdots z_k = 0$ gegeben.*

Das Theorem erlaubt uns, die Schnittzahl der Teichmüllerkurve mit dem Divisor auszurechnen. Genauer werten wir die Kohomologieklass des Divisors auf der durch die kompaktifizierte Teichmüllerkurve definierten Homologieklass aus. Eine abelsche Teichmüllerkurve, d.h. erzeugt durch das Quadrat einer holomorphen Differentialform, schneidet nur eine Komponente von \mathcal{D} , so dass wir die Kohomologieklassen aller Komponenten auswerten können.

Reduzieren wir die flachen Strukturen auf den Fasern auf die komplexen Struk-

turen, so haben wir die (Überlagerung der) universelle(n) Kurve über einer kompaktifizierten Spitze der Teichmüllerkurve konstruiert. Im Falle der abelschen Teichmüllerkurven erhalten wir auf den Fasern des Bündels holomorphe Formen anstelle der quadratischen Differentiale. Mit anderen Worten konstruieren wir einen holomorphen Schnitt im relativen Kotangentialbündel der universellen Kurve über den Spitzen. Im letzten Abschnitt nutzen wir diesen Schnitt aus, um den Nullstellendivisor eines Schnitts im relativen Tangentialbündel der universellen Kurve über einer abelschen Teichmüllerkurve zu berechnen. Da κ_1 das Bild des Quadrats der Eulerklasse des Tangentialbündels der universellen Kurve unter dem Gysinmorphismus ist, sind wir schließlich in der Lage, κ_1 auszuwerten. Wir erhalten das folgende Theorem:

Theorem 6.3. *Sei $C \rightarrow \mathcal{M}_g$ eine abelsche Teichmüllerkurve erzeugt durch eine holomorphe Differentialform mit a_k Nullstellen der Ordnung k , für $k = 1, \dots, 2g - 2$, sei $j : \bar{C} \rightarrow \bar{\mathcal{M}}_g$ ihre Kompaktifizierung. Dann gilt*

$$(\kappa_1, j_*[\bar{C}]) = \chi(C) \left(1 - g - \sum_{k=1}^{2g-2} \frac{ka_k}{2(k+1)} \right).$$

Unter Benutzung Wolperts Ergebnisse, die κ_1 in Beziehung zur Weil-Petersson-Metrik setzen, berechnen wir anschliessend die Oberfläche einer abelschen Teichmüllerkurve gemessen in dieser Metrik. Da die Oberfläche bezüglich der Teichmüllermetrik leicht durch die Eulercharakteristik ausgedrückt wird, können wir die beiden Oberflächen vergleichen. Der Quotient der beiden hängt überraschenderweise nur von den Nullstellenordnungen der erzeugenden Form ab:

Korollar 6.5. *Sei $j : C \rightarrow \mathcal{M}_g$ eine abelsche Teichmüllerkurve erzeugt durch eine holomorphe Differentialform mit a_k Nullstellen der Ordnung k , für $k = 1, \dots, 2g - 2$. Dann gilt: $\text{area}_{WP}(C) = \text{area}_{TM}(C) \left(g - 1 + \sum_{k=1}^{2g-2} \frac{ka_k}{2(k+1)} \right)$.*

Im Abschnitt 3.5 geben wir fast alle bekannten primitiven Teichmüllerkurven an. Aufgrund der Beschaffenheit einiger Beispiele ist es leider nicht immer ohne Weiteres möglich, die Ergebnisse anzuwenden. In anderen Fällen können die Schnittzahlen und die Weil-Petersson-Oberfläche präzise ausgerechnet werden, was in den Abschnitten 5.4 und 6.5 exemplarisch gemacht wird.