On the Hilbert uniformization of
moduli spaces of flat G -bundles over
Riemann surfaces

Luba Stein

On the Hilbert uniformization of moduli
spaces of flat G -bundles over Riemann
surfaces

Dissertation
zur
Erlangung des Doktorgrades (Dr. rer. nat.)
der
Mathematisch-Naturwissenschaftlichen Fakultät
der
Rheinischen Friedrich-Wilhelms-Universität Bonn

vorgelegt von

Luba Stein
aus
Leningrad (jetzt St. Petersburg)

Bonn, August 2013

Angefertigt mit Genehmigung der Mathematisch-Naturwissenschaftlichen
Fakultät der Rheinischen Friedrich-Wilhelms-Universität Bonn

1. Gutachter: Prof. Dr. Carl-Friedrich Bödigheimer

2. Gutachter: Prof. Dr. Peter Teichner

Tag der Promotion: 07.01.2014

Erscheinungsjahr: 2014

Zusammenfassung

In der vorliegenden Arbeit untersuchen wir den Modulraum $\mathcal{M}_{g,1}^m(G)$ flacher, punktierter G -Hauptfaserbündel auf Riemannschen Flächen X . Das Geschlecht von X ist $g \geq 0$ und G eine feste Liegruppe. Ferner sind $m \geq 0$ permutierbare markierte Punkte und ein gerichteter Basispunkt, d.h. ein Punkt Q mit einem Tangentialvektor $\chi \neq 0$ in Q , auf X gegeben. Die kanonische Projektion auf den Modulraum Riemannscher Flächen ergibt ein Faserbündel, dessen Faser die Darstellungsvarietät in G ist. Es werden die Zusammenhangskomponenten von $\mathcal{M}_{1,1}^m(G)$ für mehrere Liegruppen beschrieben und die Homologiegruppen für $SU(2)$ sowie $U(1)$ berechnet. Weiter können für $G = SO(3)$, $SU(2)$ und $U(2)$ einige Homotopiegruppen bestimmt werden. Im Speziellen beschäftigen wir uns mit Modulräumen von Überlagerungen auf Riemannschen Flächen. Sowohl im Falle unverzweigter als auch verzweigter Überlagerungen werden wiederum die Zusammenhangskomponenten kombinatorisch beschrieben. Im zweiten Teil der Arbeit konstruieren wir mittels einer Verallgemeinerung der Hilbertuniformisierung Riemannscher Flächen eine Zellenzerlegung für den Modulraum $\mathcal{M}_{g,1}^{(m)}(G)$ flacher, punktierter G -Hauptfaserbündel auf Riemannschen Flächen X von Geschlecht $g \geq 0$ mit $m \geq 0$ permutierbaren Punktierungen (im Gegensatz zu markierten Punkten) und einem gerichteten Basispunkt. Als Konsequenz können für einige Beispiele die Homologiegruppen berechnet werden. Zudem wird ein Stratum von filtrierten Barkomplexen bestimmter endlicher Kranzprodukte mit einer disjunkten Vereinigung von Modulräumen identifiziert. Schließlich untersuchen wir Stabilisierungseffekte der Modulräume. Zunächst betrachten wir Stabilisierungsabbildungen für $g \rightarrow \infty$. Im letzten Teil der Arbeit berechnen wir die stabilen Homotopiegruppen für $G = Sp(k)$, $SU(k)$ und $Spin(k)$ für $k \rightarrow \infty$.

Abstract

In this thesis, we study the moduli spaces $\mathcal{M}_{g,1}^m(G)$ of flat pointed principal G -bundles over Riemann surfaces X . The genus of X is $g \geq 0$ and G is a fixed Lie group. Further, we are given $m \geq 0$ permutable marked points in X and a directed base point, that is, a base point $Q \in X$ with a tangent vector $\chi \neq 0$ in Q . The canonical projection onto the moduli space of Riemann surfaces defines a fiber bundle whose fiber is the representation variety in G . Connected components of $\mathcal{M}_{1,1}^m(G)$ are described for several Lie groups G . Homology groups are computed for $G = SU(2)$ and $U(1)$. Some homotopy groups are determined for $G = SO(3)$, $SU(2)$ and $U(2)$. In particular, we analyze moduli spaces of coverings of Riemann surfaces. For ramified and unramified coverings, we combinatorially describe the connected components.

In the second part of this thesis, we construct a cell decomposition for the moduli space of flat G -bundles as an application of a generalized Hilbert uniformization. To this end, we consider the moduli spaces $\mathcal{M}_{g,1}^{(m)}(G)$ of flat pointed principal G -bundles over Riemann surfaces X of genus $g \geq 0$ with $m \geq 0$ permutable punctures (in contrast to marked points) and a directed base point. As a consequence, homology groups can be computed for some examples. Moreover, a stratum of filtered bar complexes of certain finite wreath products of groups can be identified with a disjoint union of moduli spaces. Finally, we investigate stabilization effects of the moduli spaces. First, we consider stabilization maps for $g \rightarrow \infty$. Then we compute stable homotopy groups for $G = Sp(k)$, $SU(k)$ and $Spin(k)$ as $k \rightarrow \infty$.

Contents

Einleitung	3
Introduction	17
1 Moduli spaces of flat G-bundles	30
1.1 Introduction to flat G -bundles	30
1.2 Moduli spaces from a topological viewpoint	45
1.3 Moduli spaces of flat G -bundles over tori	55
1.4 Moduli spaces of flat G -bundles for abelian groups	71
1.5 Moduli spaces of coverings	75
2 The Hilbert uniformization of flat G-bundles	91
2.1 Preliminaries to the Hilbert uniformization	91
2.2 Construction of the Hilbert uniformization	95
2.3 Topology of the Hilbert uniformization	128
2.4 Stratification of moduli spaces of flat G -bundles	140
2.5 H-space structure of the moduli space of flat G -bundles	147
3 Stable moduli spaces of flat G-bundles	164
3.1 Stabilization of the moduli space of flat G -bundles	164
3.2 Further stable structures	185
References	196
Index	200

List of Figures

1.1	Parallel transport	34
1.2	Parallel transport and change of base points	38
1.3	E_2 -term for $H^p(\mathcal{M}_{1,1}(SU(2)))$	71
1.4	E_2 -term for $H^p(\mathcal{M}_{1,1}(U(1)))$	73
1.5	Generators of the braid group	84
1.6	Commuting branch points	85
1.7	Deformation along $u_{i,j}$ in direction of a_i	87
1.8	Loop $\kappa_{i,j}$	88
1.9	Representing $\kappa_{i,j}$	89
2.1	Parallel Slit Domain	97
2.2	Gluing rules of a PSD	99
2.3	Complex atlas	101
2.4	Parallel Slit Model	102
2.5	Gluing rules of the trivial bundle over a PSD	108
2.6	Path through a vertex	118
2.7	Path through a critical point	119
2.8	Path through the dipole point	121
2.9	Cells of $\mathcal{M}_{1,1}[2]_0$	137
2.10	Assembling two PSDs	152
2.11	Assembling two PSDs with gluing functions	155
2.12	Identification along two boundary disks	156
2.13	Moving \hat{Y} around \hat{Y}^*	161

Einleitung

Eine der wichtigsten mathematischen Problemstellungen ist die Klassifikation von Objekten mit bestimmten gemeinsamen Eigenschaften. Lösungen eines geometrischen Klassifikationsproblems werden durch sogenannte Modulräume nicht nur parametrisiert, sondern ihre Topologie realisiert ein Maß, wie unterschiedlich zwei Objekte bezüglich der Klassifikation sind. Im Fokus dieser Arbeit stehen Modulräume flacher G -Hauptfaserbündel auf Riemannschen Flächen für eine feste Liegruppe G . Damit parametrisiert der Modulraum zwei Strukturen: die konforme Struktur der Riemannschen Fläche sowie die flache G -Hauptfaserbündelstruktur.

Das Modulproblem Riemannscher Flächen geht auf Riemann selbst im Jahr 1857 zurück. Seitdem wurde der Raum mit unterschiedlichsten Methoden aus der Geometrie, Analysis und Kombinatorik untersucht. Wir betrachten hier den Modulraum $\mathcal{M}_{g,1}^m$ Riemannscher Flächen X von Geschlecht $g \geq 0$ mit $m \geq 0$ permutierbaren markierten Punkten und einem gerichteten Basispunkt, d.h. einem Punkt $Q \in X$ mit einem Tangentialvektor $\chi \neq 0$ in Q . Der Modulraum besteht aus konformen Äquivalenzklassen, welche die oben genannte Struktur erhalten. Es ist der Quotient des Teichmüllerraums $\mathcal{T}_{g,1}^m$, der für $g \geq 2$ homöomorph zu einem euklidischen Raum ist, unter der Wirkung der Abbildungsklassengruppe $\Gamma_{g,1}^m$. Die Abbildungsklassengruppe ist die Gruppe der Zusammenhangskomponenten

aller orientierungserhaltender Diffeomorphismen, die den gerichteten Basispunkt sowie dessen Tangentialvektor fixieren und die Menge der markierten Punkte erhalten. Die Wirkung von $\Gamma_{g,1}^m$ auf $\mathcal{T}_{g,1}^m$ ist eigentlich diskontinuierlich und frei. Insbesondere ist der Modulraum $\mathcal{M}_{g,1}^m$ ein klassifizierender Raum von $\Gamma_{g,1}^m$ und eine topologische Mannigfaltigkeit.

Auch die Klassifikation von Bündeln ist ein klassisches Problem. Äquivalenzklassen topologischer G -Hauptfaserbündel über einem CW-Komplex X werden durch Homotopieklassen von X in den klassifizierenden Raum BG von G parametrisiert. Dagegen ist die Charakterisierung flacher G -Hauptfaserbündel ein geometrisches Problem und hängt mit dem Begriff der Holonomie von Hauptfaserbündeln zusammen, welcher von Cartan 1926 eingeführt wurde. Wird eine Riemannsche Fläche X fest gewählt, so entsprechen Äquivalenzklassen flacher G -Hauptfaserbündel G -Konjugationsklassen von Darstellungen der Fundamentalgruppe $\pi_1(X)$ nach G . Ausgestattet mit der kompakt-offenen Topologie wird die Menge der Darstellungen zu einem topologischen Raum $\mathcal{R}_G(X)$, der sogenannten Darstellungsvarietät. Aus dieser Beschreibung ist ersichtlich, dass die flache G -Hauptfaserbündelstruktur nicht von der konformen Struktur der Fläche abhängt. Somit ist ein häufiger Lösungsansatz zur Betrachtung des Modulraums flacher G -Hauptfaserbündel auf Riemannschen Flächen die Untersuchung des Modulraums $\mathcal{M}_{g,1}^m$ und der Darstellungsvarietät.

In der vorliegenden Arbeit betrachten wir den Modulraum $\mathcal{M}_{g,1}^m(G)$ flacher, punktierter G -Hauptfaserbündel auf Riemannschen Flächen von Geschlecht $g \geq 0$ mit $m \geq 0$ permutierbaren markierten Punkten und einem gerichteten Basispunkt. Die Flächen werden bis auf konforme Äquivalenz und die Bündel bis auf glatte Isomorphismen unterschieden. Im ersten Schritt widmen wir uns der Topologie des Modulraums. Sei hierzu $S_{g,1}^m$ eine orientierte Fläche

von Geschlecht $g \geq 0$ mit $m \geq 0$ markierten Punkten und einem gerichteten Basispunkt. Durch Identifikation von $\mathcal{M}_{g,1}^m(G)$ mit dem Faserprodukt $\mathcal{T}_{g,1}^m \times_{\Gamma_{g,1}^m} \mathcal{R}_G(S_{g,1}^m)$ als Menge erhält er die Quotiententopologie des direkten Produkts aus Teichmüllerraum und Darstellungsvarietät. Mehr noch folgt, dass die kanonische Projektion $\mathcal{M}_{g,1}^m(G) \rightarrow \mathcal{M}_{g,1}^m$ ein Faserbündel mit Faser $\mathcal{R}_G(S_{g,1}^m)$ ist. Eine erste natürliche Frage ergibt sich zur Bestimmung der Anzahl und Charakterisierung der Zusammenhangskomponenten von $\mathcal{M}_{g,1}^m(G)$. Da der Teichmüllerraum zusammenhängend ist, muss zur Untersuchung der Komponenten die Wirkung von $\Gamma_{g,1}^m$ auf $\mathcal{R}_G(S_{g,1}^m)$ sowie die Anzahl der Zusammenhangskomponenten der Darstellungsvarietät untersucht werden. Die Bestimmung der Zusammenhangskomponenten von $\mathcal{R}_G(S_{g,1}^m)$ ist ein schwieriges Problem und wurde für einige Beispiele von Liegruppen und $g \geq 2$ zuerst von Goldman in [26] gelöst. Er stellte dort die Hypothese auf, dass für zusammenhängende, halbeinfache und kompakte beziehungsweise komplexe Liegruppen die Zusammenhangskomponenten bijektiv zur Fundamentalgruppe $\pi_1(G)$ sind. Mehr noch lässt sich die einzige Obstruktion gegen Trivialität des Bündels mit einem bestimmten Element aus $\pi_1(G)$ identifizieren. Diese Vermutung wurde später in [38] bewiesen. Die Beweismethoden lassen sich jedoch nicht auf den Fall flacher G -Hauptfaserbündel auf Flächen von Geschlecht $g = 1$ übertragen. Daher haben wir mit klassischer Liegruppentheorie die Zusammenhangskomponenten für $U(n)$, $SU(n)$ und $Sp(n)$ bestimmt, sowie mit Hilfe hyperbolischer Geometrie die Gruppen $PSL(2, \mathbb{R})$ und $SL(2, \mathbb{R})$ betrachtet.

Als weiteres wichtiges Beispiel wurde der Modulraum $\mathcal{M}_{1,1}^m(SO(3))$ untersucht. Indem $SO(3)$ mit der Rotationsgruppe des euklidischen Raums identifiziert wird, können die zwei Zusammenhangskomponenten von $\mathcal{R}_{SO(3)}(S_{1,1})$ mit Hilfe bestimmter Paare von Rotationen beschrieben werden (siehe [3]).

Unter Verwendung dieses Resultats lässt sich die folgende Charakterisierung aufstellen (siehe Satz 1.3.5).

Satz. *Der Modulraum $\mathcal{M}_{1,1}^m(SO(3))$ besteht aus zwei Zusammenhangskomponenten, welche durch die zweiten Stiefel–Whitney-Klassen der zu den $SO(3)$ -Hauptfaserbündeln assoziierten Vektorraumbündel charakterisiert werden. Genauer gesagt, besteht eine Komponente aus topologisch trivialen Bündeln, während die andere Komponente Bündel mit einer nicht trivialen zweiten Stiefel–Whitney-Klasse enthält. Die Fundamentalgruppe der Zusammenhangskomponente des trivialen Bündels ist isomorph zu $(\mathbb{Z}/2)^2 \rtimes \Gamma_{1,1}^m$.*

Der Beweis des Satzes basiert auf klassischen Fundamentalgruppentechniken. Als Korollar erhalten wir die Fundamentalgruppen der Modulräume $\mathcal{M}_{1,1}^m(SU(2))$ und $\mathcal{M}_{1,1}^m(U(2))$.

In der Regel sind konkrete Berechnungen sehr schwierig und lassen sich nur für Beispiellklassen durchführen. Zwei wichtige solche Klassen sind durch abelsche und endliche Gruppen gegeben. Eine zusammenhängende abelsche Liegruppe ist isomorph zum direkten Produkt eines Torus und eines euklidischen Raums. In diesem Fall gilt dann die folgende Beschreibung für den Modulraum (siehe Korollar 1.4.2).

Korollar. *Sei G eine zusammenhängende abelsche Liegruppe. Dann ist $\mathcal{M}_{g,1}^m(G)$ ein klassifizierender Raum mit $\mathbb{Z}^{2gp} \rtimes \Gamma_{g,1}^m$ als Fundamentalgruppe, wobei p die Dimension des maximalen Torus von G ist.*

Zur Untersuchung der Zusammenhangskomponenten des Modulraums K -blättriger, unverzweigter Überlagerungen $\mathcal{M}_{g,1}[K]$ in Abschnitt 1.5 haben wir vorwiegend kombinatorische Methoden verwendet. Die Strukturgruppe ist die symmetrische Gruppe auf K Elementen \mathfrak{S}_K . Die geänderte Notation ist dadurch begründet, dass die Strukturgruppe \mathfrak{S}_K auf K Punkten und

nicht auf sich selbst wirken soll. Durch die Zerlegung jeder Fläche in Teilflächen der Charakteristik -1 können wir das Problem auf die Spezialfälle des Torus und der drei Mal berandeten Sphäre reduzieren. Für den Torus lassen sich die Zusammenhangskomponenten des Modulraums durch bestimmte transitive Untergruppen der symmetrischen Gruppe beschreiben. Im Fall der berandeten Sphäre werden die Zusammenhangskomponenten durch Bahnen der reinen Zopfgruppe auf den Monodromiedarstellungen identifiziert. Durch zusätzliche Untersuchung der Zusammenhangskomponenten jeder Überlagerung kann Satz 1.5.5 geschlossen werden. Sei hierzu $b_0(M)$ die Anzahl der Zusammenhangskomponenten eines topologischen Raums M .

Satz. *Die Anzahl der Zusammenhangskomponenten $b_0(\mathcal{M}_{g,1}[K])$ ist eine Funktion von $b_0(\mathcal{M}_{1,1}[K])$, $b_0(\mathcal{H}_3[K])$ und dem Geschlecht g , wobei $\mathcal{H}_r[K]$ der Hurwitzraum K -blättriger Überlagerungen mit $r \geq 1$ Verzweigungspunkten ist.*

(1) *Die Anzahl $b_0(\mathcal{M}_{1,1}[K])$ ist eine Funktion der Anzahl der Partitionen von K und der Anzahl aller transitiver Untergruppen $H \leq \mathfrak{S}_K$, für welche folgendes gilt. Es existieren $s, t \in \mathbb{N}$ so, dass H eine Untergruppe des Kranzprodukts $\mathbb{Z}/s\mathbb{Z} \wr C_t$ für die zyklische Gruppe C_t der Ordnung t ist.*

(2) *Die Anzahl $b_0(\mathcal{H}_r[K])$ ist gleich der Anzahl der Bahnen der reinen Zopfgruppe auf der Menge der Monodromiedarstellungen.*

Es lassen sich damit für einige Beispiele die Anzahl der Zusammenhangskomponenten explizit berechnen. Als allgemeines Resultat erhalten wir jedoch eine obere Schranke.

Eine weitere interessante Schlussfolgerung aus Satz 1.5.5 ist die Bestimmung

der Anzahl der Zusammenhangskomponenten des Modulraums verzweigter Überlagerungen $\mathcal{M}_{g,1}[K]_*$ (siehe Korollar 1.5.6).

Korollar. *Der Modulraum $\mathcal{M}_{g,1}[K]_*$ hat unendlich viele Komponenten.*

In Anbetracht von (2) aus Satz 1.5.5 wird schließlich in Satz 1.5.11 die Gruppenwirkung der Zopfgruppe auf der Menge der Monodromiedarstellungen mit kombinatorischen Methoden berechnet.

Schließlich ist die Bestimmung der Homologiegruppen eine zentrale topologische Frage. Da die kanonische Projektion von $\mathcal{M}_{g,1}^m(G)$ auf $\mathcal{M}_{g,1}^m$ ein Faserbündel ist, kann die Leray–Serre-Spektralsequenz für die Fälle $\mathcal{M}_{1,1}(SU(2))$ und $\mathcal{M}_{1,1}(U(1))$ aufgestellt werden. Leider hat dieser Ansatz in vielen anderen Fällen Grenzen, weil die Differentiale unbekannt sind oder der E_2 -Term nicht vollständig ermittelt werden kann. Eine typische alternative Herangehensweise zur Homologieberechnung ist die Konstruktion einer Zellenzerlegung. Dies ist das Hauptziel der Hilbertuniformisierung und wird in Kapitel 2 durchgeführt. Die Hilbertuniformisierung ist eine auf Hilbert zurückgehende Methode. Mit Hilfe dieser hat Bödiger in [9] einen Zellenkomplex konstruiert, welcher homotopieäquivalent zum Modulraum Riemannscher Flächen $\mathcal{M}_{g,1}^m$ ist. Eines unserer primären Ziele ist es diese Methode für Modulräume flacher, punktierter G -Hauptfaserbündel zu verallgemeinern. Aus technischen Gründen werden wir dies für den Modulraum $\mathcal{M}_{g,1}^{(m)}(G)$ flacher, punktierter G -Hauptfaserbündel über Riemannschen Flächen von Geschlecht $g \geq 0$ mit $m \geq 0$ permutierbaren Punktierungen und einem gerichteten Basispunkt durchführen. Der Grund hierfür ist, dass die Holonomie um eine Punktierung nicht zwangsläufig trivial ist. Sei X eine Riemannsche Fläche von Genus $g \geq 0$ mit $m \geq 0$ Punktierungen P_1, \dots, P_m und einem gerichteten Basispunkt (Q, χ) . Zu der konformen Klasse $\mathcal{F} = [X, P_1, \dots, P_m, Q, \chi]$ und positiven reellen Konstanten

b, c_1, \dots, c_m mit $\sum_{1 \leq j \leq m} c_j = b$ existiert eine Potentialfunktion $u : X \rightarrow \bar{\mathbb{R}}$. Eine Potentialfunktion ist harmonisch auf $X - \{P_1, \dots, P_m, Q\}$ und lokal bei Q von der Form $\Re\epsilon\left(\frac{1}{z}\right) - b \Re\epsilon(\log(z)) + f(z)$, wo f harmonisch ist, und lokal um P_j von der Form $c_j \Re\epsilon(\log(z)) + f_j(z)$ für eine harmonische Funktion f_j und $1 \leq j \leq m$. Mit Hilfe des Gradientenvektorfelds von u kann der kritische Graph \mathcal{K} konstruiert werden. Die Ecken des Graphen sind durch $\{P_1, \dots, P_m, Q\}$ und die kritischen Punkte von u gegeben. Kanten zwischen zwei Ecken sind Trajektorien des Gradientenvektorfelds von einem kritischen Punkt in eine Punktierung oder in Q , oder zwischen zwei kritischen Punkten. Das Komplement $X - \mathcal{K}$ ist ein einfach zusammenhängendes Gebiet, auf dem u harmonisch ist. Folglich ist u der Realteil einer holomorphen Funktion $w = u + \sqrt{-1}v$. Das Bild von w ist die komplexe Ebene, durch welche parallel zur reellen Achse Schlitze verlaufen, die aus dem negativ Unendlichen kommen und in \mathbb{C} enden. Wir nennen ein solches Bild ein Parallelschlitzgebiet (siehe Abbildung 2.1). Durch Normierung des Parallelschlitzgebiets ergeben die Werte der kritischen Punkte von u und v baryzentrische Koordinaten. Zusätzlich werden durch die Uniformisierung in ein Parallelschlitzgebiet eindeutige Permutationen $\sigma_0, \dots, \sigma_q$ determiniert, welche als Verklebedaten für die Riemannsche Fläche fungieren. Damit wird ein Punkt in einer simplizialen Zelle definiert, deren Dimension von der Eulercharakteristik und der Potentialfunktion abhängt. Andererseits kann diese Konstruktion umgekehrt werden. Mit Hilfe baryzentrischer Koordinaten lässt sich eindeutig ein Parallelschlitzgebiet angeben. Es wird durch ein Gitter unterteilt, dessen Horizontalen aus den Schlitzen und ihren Verlängerungen bestehen, und die Vertikalen durch die Schlitzenden definiert sind (siehe Abbildung 2.2). Das Parallelschlitzgebiet ist damit in Rechtecke $R_{i,j}$ für $0 \leq i \leq q$, $0 \leq j \leq p$ und $q \leq 2g + m$, $p \leq 4g + 2m$ unterteilt.

Wir betrachten das sogenannte erweiterte Parallelschlitzgebiet dazu. Es ist die disjunkte Vereinigung der abgeschlossenen Rechtecke und damit ebenfalls durch das Gitter unterteilt. Nach Wahl von Permutationen $\sigma_i \in \mathfrak{S}_p^0$ aus der symmetrischen Gruppe von $\{0, \dots, p\}$ für $0 \leq i \leq q$ lautet die Verklebevorschrift für das erweiterte Parallelschlitzgebiet, dass die obere Seite von $R_{i,j}$ mit der unteren Seite von $R_{i,\sigma_i(j)}$ verklebt wird, und die linke Seite von $R_{i,j}$ mit der rechten Seite von $R_{i+1,j}$. Natürlich induzieren nicht beliebige solche Wahlen eine reguläre Riemannsche Fläche. Es können jedoch geeignete Bedingungen an die Permutationen gestellt werden. Unter Verwendung dieser Regeln kann schließlich ein Zellenkomplex $\mathfrak{P}_{g,1}^m$ konstruiert werden, der homotopieäquivalent zu $\mathcal{M}_{g,1}^m$ ist.

Dieses Verfahren wird in Kapitel 2 verallgemeinert, um einen Zellenkomplex $\mathfrak{P}_{g,1}^m(G)$ zu erhalten, welcher homotopieäquivalent zum Modulraum $\mathcal{M}_{g,1}^{(m)}(G)$ ist. Die Idee besteht darin, aus jedem flachen G -Hauptfaserbündel über einer Riemannschen Fläche das triviale G -Hauptfaserbündel über dem entsprechenden Parallelschlitzgebiet zu konstruieren. Gleichfalls kann diese Prozedur umgekehrt werden, so dass durch Angabe entsprechender Verklebeabbildungen das triviale G -Hauptfaserbündel über einem Parallelschlitzgebiet zu einem flachen G -Hauptfaserbündel über einer Riemannschen Fläche identifiziert wird. Sei hierzu $\pi : E \rightarrow X$ ein G -Hauptfaserbündel mit flacher Zusammenhangsform A und $u : X \rightarrow \bar{\mathbb{R}}$ eine Potentialfunktion auf X . Für den Kodimension eins Unterraum $\mathcal{K}^* = \pi^{-1}(\mathcal{K})$ von E ist das Komplement $E - \mathcal{K}^*$ homöomorph zum direkten Produkt aus dem dazugehörigen Parallelschlitzgebiet und der Liegruppe G . Andererseits sei das erweiterte Parallelschlitzgebiet Y mit Verklebeabbildungen $(\sigma_i)_i$ gegeben und in Rechtecke $R_{i,j}$ für $0 \leq i \leq q$ und $0 \leq j \leq p$ unterteilt. Sei $R_{i,j}^\xi$ das Rechteck $R_{i,j} \times \{\xi\}$ für $\xi \in G$ in $Y \times G$. Für alle Paare (i,j) seien Elemente $\gamma_{i,j} \in G$ gewählt. Dann

ist die Identifikation für die Umkehrung der Hilbertuniformisierung wie folgt. Die obere Seite von $R_{i,j}^\xi$ wird mit der unteren Seite von $R_{i,\sigma_i(j)}^{\gamma_{i,j}\xi}$ verklebt, und die linke Seite von $R_{i,j}^\xi$ mit der rechten Seite von $R_{i+1,j}^\xi$. Erneut müssen die Elemente $(\gamma_{i,j}, \sigma_i)_{i,j}$ Bedingungen erfüllen (siehe Abschnitt 2.2), welche den Zellenkomplex $\mathfrak{P}_{g,1}^m(G)$ charakterisieren. Als Resultat erhalten wir eine Zellenzerlegung von $\mathcal{M}_{g,1}^{(m)}(G)$.

Die genaue Formulierung der Hilbertuniformisierung ist sogar noch stärker. Sei $\mathfrak{H}_{g,1}^m(G)$ der Raum bestehend aus allen Äquivalenzklassen $[E, \pi, X, A, u]$, wobei $[E, \pi, X, A] \in \mathcal{M}_{g,1}^{(m)}(G)$ und u eine Potentialfunktion auf X ist. Aus den Eigenschaften von Potentialfunktionen folgt, dass $\mathfrak{H}_{g,1}^m(G) \rightarrow \mathcal{M}_{g,1}^{(m)}(G)$ ein affines Bündel ist (siehe [9]). Insbesondere sind $\mathfrak{H}_{g,1}^m(G)$ und $\mathcal{M}_{g,1}^{(m)}(G)$ homotopieäquivalent und es gilt das folgende zentrale Resultat (siehe Satz 2.3.7).

Satz. *Die Hilbertuniformisierung definiert einen Homöomorphismus*

$$\mathcal{H}(G) : \mathfrak{H}_{g,1}^m(G) \rightarrow \mathfrak{P}_{g,1}^m(G).$$

Unter Verwendung dieser Zellenzerlegung lässt sich für einige einfache Beispiele die simpliziale Homologie bestimmen (siehe Beispiel 2.3.9).

Beispiel. Für den Modulraum $\mathcal{M}_{1,1}[2]_0$ unverzweigter, zusammenhängender 2-blättriger Überlagerungen über dem Torus mit einem Dipolpunkt ist

$$H_n(\mathcal{M}_{1,1}[2]_0; \mathbb{Z}) \cong \begin{cases} \mathbb{Z}, & n = 0, 2 \\ \mathbb{Z}^2, & n = 1 \\ 0, & \text{sonst.} \end{cases}$$

Trotzdem ergeben sich schnell Schwierigkeiten, obwohl die Hilbertuni-

formisierung eine konstruktive Methode zur Berechnung der Homologie ermöglicht. Diese erwachsen aus der numerischen Komplexität des Problems, denn die Anzahl der Zellen steigt exponentiell mit größer werdenden g , m und G .

Die Hilbertuniformisierung hat jedoch noch weitere sehr interessante Konsequenzen. Es ist möglich, ein Stratum bestimmter filtrierter Barkomplexe mit einer disjunkten Vereinigung von Modulräumen $\mathcal{M}_{g,1}^{(m)}(G)$ zu identifizieren. Sei G eine endliche Gruppe der Ordnung $|G|$, realisiert als Untergruppe der symmetrischen Gruppe auf $|G|$ Elementen $\mathfrak{S}_{|G|}$. Dann ist das Kranzprodukt $G \wr \mathfrak{S}_p$ eine Untergruppe von $\mathfrak{S}_{|G|p}$ für alle $p \geq 0$. Wir betrachten auf $G \wr \mathfrak{S}_p$ die Wortlängennorm bezüglich aller Transpositionen. Sei $B(G \wr \mathfrak{S}_p)$ der Barkomplex, und $\mathcal{F}_{(h)}B(G \wr \mathfrak{S}_p)$ bestehe aus allen Elementen des Barkomplexes, deren Produktnorm (bezüglich der Wortlängennorm) gleich $h \in \mathbb{N}$ ist. Sei $\mathcal{M}_{g,1}^{(m)}[|G|]^G$ der Modulraum unverzweigter, $|G|$ -blättriger Überlagerungen mit Strukturgruppe G über einer Riemannschen Fläche von Geschlecht $g \geq 0$ mit $m \geq 0$ permutierbaren Punktierungen und einem gerichteten Basispunkt. Dann induziert die Hilbertuniformisierung die Homotopieäquivalenz (siehe Satz 2.4.4)

$$\coprod_{h=|G|(2g+m)} \mathcal{M}_{g,1}^{(m)}[|G|]^G \longrightarrow \mathcal{F}_{(h)}B(G \wr \mathfrak{S}_*).$$

Dieses Resultat ist insbesondere im Hinblick auf die Arbeit Visys [53] von Interesse, wo mit Hilfe solcher Normfiltrierungen Komplexe zur Berechnung der Kohomologie sogenannter faktorabler Gruppen aufgestellt wurden. Alle Gruppen in unserem Resultat sind faktorabel bezüglich der Norm des semidirekten Produkts, welche durch die triviale Norm auf G und die Wortlängennorm der symmetrischen Gruppe definiert ist. Damit wird eine direkte

Beziehung zwischen geometrischen Objekten, den Modulräumen, und einem rein algebraischen Konzept, der Kohomologie von Gruppen, hergestellt. Es folgt sogar aus unseren Überlegungen, dass $\mathcal{F}_{(h)}B(G \wr \mathfrak{S}_*)$ homöomorph zu einer topologischen Mannigfaltigkeit ist (siehe Korollar 1.2.10).

Zuletzt wollen wir auf einen anderen Aspekt eingehen, der für neuere Untersuchungen von Modulräumen Riemannscher Flächen von großer Bedeutung ist. Wir betrachten im letzten Kapitel Stabilisierungseffekte von $\mathcal{M}_{g,1}(G)$. Die erste wichtige Idee hierbei geht auf Harer [30] zurück. Er zeigte unter Verwendung bestimmter Stabilisierungsabbildungen für die Abbildungsklassengruppe $\Gamma_{g,n}$, dass für $g \gg 0$ die Homologie $H_q(B\Gamma_{g,n})$ nicht von g und n abhängt. Hier wird $\Gamma_{g,n}$ als die Abbildungsklassengruppe Riemannscher Flächen von Geschlecht $g \geq 0$ mit $n \geq 0$ Randkomponenten betrachtet. Mit Hilfe von Harers Ergebnissen hat Tillmann später nachgewiesen, dass $\mathbb{Z} \times B\Gamma_{g,n}^+$ ein unendlicher Schleifenraum ist, wobei $B\Gamma_{g,n}^+$ die Plus-Konstruktion bezeichnet (siehe [50]). Beide Resultate wurden in [17], [18] und [19] für den Modulraum flacher G -Hauptfaserbündel verallgemeinert. Ein zentrales Element hierbei ist, dass die Stabilisierungsabbildungen mit Hilfe der zusammenhängenden Summe entlang von Randkomponenten definiert werden. Es sei zusätzlich bemerkt, dass über den Rändern beide Bündel der Summe trivial sind, und so kanonisch identifiziert werden können. Damit ergeben sich durch die Basis des Bündels, d.h. die Riemannsche Fläche, Stabilisierungsabbildungen.

Jedoch existiert auf $\mathcal{M}_{g,1}(G)$ eine weitere Stabilisierungsabbildung für bestimmte Wahlen der Liegruppe G . Sei hierzu $G = G(k)$ eine der klassischen Matrixgruppen $Sp(k)$, $SU(k)$ oder $Spin(k)$. Für die klassifizierenden Räume dieser Gruppen hat Bott eines der ersten großen Stabilitätsresultate gezeigt (siehe [14]). Unter Verwendung von Methoden aus [5] (siehe Satz 3.2.1)

folgt, dass für $k \gg 0$ die Homotopiegruppen $\pi_q(\mathcal{M}_{g,1}(G(k)))$ nicht von k abhängen (siehe Satz 3.2.3).

Satz. Sei X eine kompakte, orientierte und zusammenhängende Fläche von Geschlecht $g \geq 2$. Dann ist $\mathcal{R}i_k : \mathcal{R}_{G(k)}(X) \rightarrow \mathcal{R}_{G(k+1)}(X)$

(1) $(4k - 4)$ -zusammenhängend für $G(k) = Sp(k)$.

(2) $(2k - 2)$ -zusammenhängend für $G(k) = SU(k)$.

(3) $(k - 3)$ -zusammenhängend für $G(k) = Spin(k)$.

Zudem lassen sich mit Bott-Periodizität diese stabilen Homotopiegruppen explizit berechnen (siehe Korollar 3.2.4).

Korollar. Sei $\mathop{\mathrm{hocolim}}_k \mathcal{R}_{G(k)}(X) = \mathcal{R}_\infty^G(X)$ für $G(k)$ eine der klassischen Familien zusammenhängender, kompakter, halbeinfacher Liegruppen $Sp(k)$, $SU(k)$ oder $Spin(k)$. Die Homotopiegruppen von $\mathcal{R}_\infty^G(X)$ sind wie folgt.

$$(1) \quad \pi_q(\mathcal{R}_\infty^{Sp}(X)) \cong \begin{cases} \mathbb{Z}, & q \equiv 0 \pmod{8} \\ 0, & q \equiv 1, 2 \pmod{8} \\ \mathbb{Z}^{2g}, & q \equiv 3, 7 \pmod{8} \\ (\mathbb{Z}/2)^{2g} \times \mathbb{Z}, & q \equiv 4 \pmod{8} \\ (\mathbb{Z}/2)^{2g+1}, & q \equiv 5 \pmod{8} \\ \mathbb{Z}/2, & q \equiv 6 \pmod{8}. \end{cases}$$

$$(2) \quad \pi_q(\mathcal{R}_\infty^{SU}(X)) \cong \begin{cases} \mathbb{Z}, & q \equiv 0 \pmod{2} \\ \mathbb{Z}^{2g}, & q \equiv 1 \pmod{2}. \end{cases}$$

(3)

$$\pi_q(\mathcal{R}_\infty^{Spin}(X)) \cong \begin{cases} (\mathbb{Z}/2)^{2g} \times \mathbb{Z}, & q \equiv 0 \pmod{8} \\ (\mathbb{Z}/2)^{2g+1}, & q \equiv 1 \pmod{8} \\ \mathbb{Z}/2, & q \equiv 2 \pmod{8} \\ \mathbb{Z}^{2g}, & q \equiv 3, 7 \pmod{8} \\ \mathbb{Z}, & q \equiv 4 \pmod{8} \\ 0, & q \equiv 5, 6 \pmod{8}. \end{cases}$$

Die Arbeit ist wie folgt aufgebaut. Im ersten Kapitel führen wir einige grundsätzliche Begriffe zu flachen Zusammenhängen auf Hauptfaserbündeln ein und betrachten die Topologie des Modulraums. Es werden für die erwähnten Beispiele einige Homologie- und Homotopiegruppen bestimmt sowie Zusammenhangskomponenten charakterisiert. In Abschnitt 1.5 widmen wir uns Modulräumen von Überlagerungen unter Verwendung kombinatorischer Methoden. Das zweite Kapitel wird der Hilbertuniformisierung flacher G -Hauptfaserbündel auf Riemannschen Flächen gewidmet. Wir geben die Konstruktion der Hilbertuniformisierung an und zeigen, dass diese einen Homöomorphismus vom Raum flacher G -Hauptfaserbündel mit Potentialfunktion auf einen Zellenkomplex induziert. Schließlich werden in Abschnitt 2.4 die Beziehung zur Normfiltrierung $\mathcal{F}_{(h)}B(G \wr \mathfrak{S}_*)$ hergestellt und in Abschnitt 2.5 mit Hilfe von Parallelschlitzgebieten eine H-Raumstruktur auf einer disjunkten Vereinigung von Modulräumen untersucht. Unsere Überlegungen zur H-Raumstruktur basieren auf Resultaten aus [10]. Im dritten Kapitel beschäftigen wir uns mit der stabilen Topologie der Modulräume und konstruieren in Abschnitt 3.1 Dyer–Lashof-Operationen. Im letzten Teil der Ar-

beit werden die stabilen Modulräume $\mathcal{M}_{g,1}(G(k))$ für $G(k) = Sp(k)$, $SU(k)$, $Spin(k)$ und $k \rightarrow \infty$ untersucht sowie die stabilen Homotopiegruppen berechnet.

Introduction

One of the most important mathematical questions is the classification of objects with certain common properties and which are subject to a suitable notion of equivalence. The resulting quotient space usually carries a natural topology. Solutions of the geometric classification problem are not only parameterized by so-called moduli spaces but their topology characterizes a measure to which extent two objects are different. We focus on moduli spaces of flat principal G -bundles over Riemann surfaces for a fixed Lie group G . Therefore, the moduli space parameterizes two structures: the conformal structure of the Riemann surface and the flat G -bundle structure.

The moduli problem of Riemann surfaces goes back to Riemann in 1857. This space and variations thereof were studied by means of different geometric, analytic and combinatorial methods. In this thesis, we consider the moduli space $\mathcal{M}_{g,1}^m$ of Riemann surfaces X of genus $g \geq 0$ with $m \geq 0$ permutable marked points and a directed base point, that is, a base point $Q \in X$ with a tangent vector $\chi \neq 0$ in Q . The moduli space consists of conformal equivalence classes which preserve this structure. It is the quotient of the Teichmüller space $\mathcal{T}_{g,1}^m$, which is homeomorphic to an Euclidean space for $g \geq 2$, under the action of the mapping class group $\Gamma_{g,1}^m$. The latter is the group of connected components of all orientation preserving diffeomorphisms that fix the directed base point with its tangent vector and the set of

marked points. The action of $\Gamma_{g,1}^m$ on $\mathcal{T}_{g,1}^m$ is properly discontinuous and free. In particular, $\mathcal{M}_{g,1}^m$ is a topological manifold and a model for the classifying space $B\Gamma_{g,1}^m$.

Likewise, the classification of bundles is a classical problem. Equivalence classes of topological principal G -bundles over a CW-complex X are classified by homotopy classes of maps from X to the classifying space BG of G . On the other hand, the characterization of flat principal G -bundles is a geometric problem. It is related to the notion of holonomy which was introduced by Cartan in 1926. If a Riemann surface is fixed equivalence classes of flat principal G -bundles correspond to G -conjugacy classes of representations of the fundamental group $\pi_1(X)$ in G . The set of these representations equipped with the compact-open topology is called the representation variety $\mathcal{R}_G(X)$. From this description it follows that the flat G -bundle structure does not depend on the conformal structure of the Riemann surface. Thus, a frequent theme in the study of moduli spaces of flat G -bundles will be to analyze $\mathcal{M}_{g,1}^m$ and the representation variety.

In this text, we consider the moduli space $\mathcal{M}_{g,1}^m(G)$ of flat pointed G -bundles over Riemann surfaces of genus $g \geq 0$ with $m \geq 0$ permutable marked points and a directed base point. The surfaces are characterized up to conformal equivalence and the bundles up to smooth isomorphisms. In a first step, we draw our attention to the topology of the moduli space. For this, let $S_{g,1}^m$ be an oriented surface of genus $g \geq 0$ with $m \geq 0$ marked points and a directed base point. By identification of $\mathcal{M}_{g,1}^m(G)$ with $\mathcal{T}_{g,1}^m \times_{\Gamma_{g,1}^m} \mathcal{R}_G(S_{g,1}^m)$ as a set it is equipped with the quotient topology of the direct product. Even more, it follows that the canonical projection $\mathcal{M}_{g,1}^m(G) \rightarrow \mathcal{M}_{g,1}^m$ is a fiber bundle with fiber $\mathcal{R}_G(S_{g,1}^m)$. A natural question to ask is to determine the number or to characterize the connected components of $\mathcal{M}_{g,1}^m(G)$. Since the Teich-

müller space is connected we need to determine the connected components of $\mathcal{R}_G(S_{g,1}^m)$ and how the mapping class group acts upon these. The computation of the connected components of $\mathcal{R}_G(S_{g,1}^m)$ is a difficult problem. For some examples of Lie groups, this was solved by Goldman in [26] if $g \geq 2$. There he raised the conjecture that the connected components are in bijective correspondence with the fundamental group $\pi_1(G)$ for G a connected, semisimple and complex and compact Lie group, respectively. Even more, the only obstruction against the triviality of the bundle is a certain element from $\pi_1(G)$. This conjecture was later proved in [38].

However, the methods of the proof do not work for the case of flat principal G -bundles over surfaces of genus $g = 1$. Therefore, we have determined the connected components for $U(n)$, $Sp(n)$ and $SU(n)$ by classical Lie group techniques. Moreover, we considered the groups $PSL(2, \mathbb{R})$ and $SL(2, \mathbb{R})$ using hyperbolic geometry.

A further important example is the moduli space $\mathcal{M}_{1,1}^m(SO(3))$. By identifying $SO(3)$ with the rotation group of the Euclidean space the two connected components of $\mathcal{R}_{SO(3)}(S_{1,1})$ can be described by means of certain pairs of rotations (see [3]). Applying this result, the connected components are characterized as follows (see Theorem 1.3.5).

Theorem. *The moduli space $\mathcal{M}_{1,1}^m(SO(3))$ consists of two connected components which are characterized by the second Stiefel–Whitney classes of the associated vector bundles to the principal $SO(3)$ -bundles. More precisely, one component consists of topologically trivial bundles while the other component contains bundles with a nontrivial second Stiefel–Whitney class. The fundamental group of the connected component containing the trivial bundle is isomorphic to $(\mathbb{Z}/2)^2 \rtimes \Gamma_{1,1}^m$.*

As a corollary we obtain the fundamental groups of the moduli spaces

$\mathcal{M}_{1,1}^m(SU(2))$ and $\mathcal{M}_{1,1}^m(U(2))$.

In general, concrete computations are hard to carry out and can be done only for some example classes. Two important classes are given by abelian and finite groups, respectively. A connected abelian Lie group is isomorphic to a direct product of a torus and a Euclidean space. In this case, the moduli space can be described as follows (see Corollary 1.4.2).

Corollary. *Let G be a connected abelian Lie group. Then $\mathcal{M}_{g,1}^m(G)$ is a classifying space with fundamental group $\mathbb{Z}^{2gp} \rtimes \Gamma_{g,1}^m$ where p is the dimension of the maximal torus of G .*

To examine connected components of the moduli space of pointed, K -sheeted unramified coverings $\mathcal{M}_{g,1}[K]$ we mostly apply combinatorial techniques (see Section 1.5). The structure group is the symmetric group on K elements. We changed the notation for the moduli spaces since the structure group \mathfrak{S}_K should act on K points and not on itself. By decomposing each surface in subsurfaces of characteristic -1 we are in a position to reduce the question to the following special cases. Namely, we get the torus and the sphere with three boundary components. In case of the torus, the connected components of the moduli space can be described by means of certain transitive subgroups of the symmetric group. For the bounded sphere, the connected components are identified by orbits of the pure braid group acting on all monodromy representations. Finally, Theorem 1.5.5 follows after examining the number of connected components of each covering. To state the theorem we denote by $b_0(M)$ the number of connected components of a topological space M .

Theorem. *The number of connected components $b_0(\mathcal{M}_{g,1}[K])$ is a function of $b_0(\mathcal{M}_{1,1}[K])$, $b_0(\mathcal{H}_3[K])$ and the genus g . Here we denote by $\mathcal{H}_r[K]$ the Hurwitz space of K -sheeted coverings with $r \geq 1$ branch points.*

- (1) The number $b_0(\mathcal{M}_{1,1}[K])$ is a function of the number of partitions of K and the number of all transitive subgroups $H \leq \mathfrak{S}_K$ satisfying the following property. There are $s, t \in \mathbb{N}$ so that H is a subgroup of the wreath product $\mathbb{Z}/s\mathbb{Z} \wr C_t$ for the cyclic group C_t of order t .
- (2) The number $b_0(\mathcal{H}_r[K])$ equals the number of orbits of the pure braid group PB_r on the set of monodromy representations.

As a consequence, we are in a position to compute the number of connected components in some cases. In general, we still obtain an upper bound.

A further interesting implication of Theorem 1.5.5 is the computation of the number of connected components of the moduli space of ramified coverings $\mathcal{M}_{g,1}[K]_*$ (see Corollary 1.5.6).

Corollary. *The moduli space $\mathcal{M}_{g,1}[K]_*$ has infinitely many connected components.*

Besides, in view of (2) of Theorem 1.5.5 we calculate the group action of the braid group on the set of monodromy representations by means of combinatorial methods in Theorem 1.5.11.

Another central question is the calculation of homology groups. Since the canonical projection of $\mathcal{M}_{g,1}^m(G)$ to $\mathcal{M}_{g,1}^m$ is a fiber bundle the Leray–Serre spectral sequence can be applied to $\mathcal{M}_{1,1}(SU(2))$ and $\mathcal{M}_{1,1}(U(1))$. Unfortunately, this technique is limited for other examples since the differentials or the E_2 -term are unknown. A typical alternative approach is to construct a cell decomposition. This is the main goal of the Hilbert uniformization and is presented in Chapter 2. The Hilbert uniformization is a method which goes back to Hilbert. It was applied by Bödigheimer in [9] to construct a cell complex that is homotopy equivalent to the moduli space $\mathcal{M}_{g,1}^m$. One of our primary objectives is to generalize this method to moduli spaces of

flat G -bundles over Riemann surfaces. For technical reasons, we will work with the moduli space $\mathcal{M}_{g,1}^{(m)}(G)$ of flat, pointed principal G -bundles over Riemann surfaces of genus $g \geq 0$ with $m \geq 0$ permutable punctures and a directed base point. The reason for this slight change is that the holonomy is not necessarily trivial at punctures. Let X be a Riemann surface of genus $g \geq 0$ with punctures P_1, \dots, P_m and a directed base point (Q, χ) . Given a conformal class $\mathcal{F} = [X, P_1, \dots, P_m, Q, \chi]$ and positive real constants b, c_1, \dots, c_m such that $\sum_{1 \leq j \leq m} c_j = b$ there exists a potential function $u : X \rightarrow \bar{\mathbb{R}}$. A potential function is harmonic on $X - \{P_1, \dots, P_m, Q\}$. Near Q it is of the form $\Re(\frac{1}{z}) - b \Re(\log(z)) + f(z)$ for a harmonic function f , while near P_j it is of the form $c_j \Re(\log(z)) + f_j(z)$ where f_j is harmonic for $1 \leq j \leq m$. By means of the gradient vector field of u , the critical graph \mathcal{K} can be constructed. Its vertices are $\{P_1, \dots, P_m, Q\}$ and the critical points of u . An edge between two vertices is given by a trajectory of the gradient vector field from a critical point into Q or into a puncture, or between two critical points. The complement $X - \mathcal{K}$ is a simply connected domain where u is harmonic. Hence, u is the real part of a holomorphic function $w = u + \sqrt{-1}v$. The image of w is the complex plane subdivided into slits along horizontal lines (parallel to the real axis) coming from minus infinity whose end points lie in \mathbb{C} . We call such an image a parallel slit domain (see Figure 2.1). After normalizing the parallel slit domain the critical points of u and v yield barycentric coordinates. In addition, permutations $\sigma_0, \dots, \sigma_q$ are uniquely determined from the uniformization process of the parallel slit domain which serve as gluing functions for the Riemann surface. So a point is defined in a simplicial cell. The dimension of this cell depends on the Euler characteristic of the surface and the potential function. On the other hand, this construction can be reversed. Given barycentric coordinates there is a

unique parallel slit domain. It is subdivided by a grid whose horizontal lines are given by the slits and its extensions while the vertical lines are determined by the slit end points (see Figure 2.2). So the parallel slit domain is subdivided into rectangles $R_{i,j}$ for $0 \leq i \leq q$, $0 \leq j \leq p$ and $q \leq 2g + m$, $p \leq 4g + 2m$. We consider the so-called extended parallel slit domain to it. It is the disjoint union of the closed rectangles and so it is also subdivided by the grid. After choosing permutations $\sigma_i \in \mathfrak{S}_p^0$ from the symmetric group of $\{0, \dots, p\}$ for $0 \leq i \leq q$ the gluing condition for the extended parallel slit domain can be stated as follows. The upper side of $R_{i,j}$ is glued to the lower side of $R_{i,\sigma_i(j)}$ and the left hand side of $R_{i,j}$ is glued to the right hand side of $R_{i+1,j}$. Arbitrary choices won't induce a regular Riemann surface but there are suitable conditions on the permutations for this. By means of these identification rules, a cell complex $\mathfrak{P}_{g,1}^m$ can be constructed which is homotopy equivalent to $\mathcal{M}_{g,1}^m$.

This method is generalized in Chapter 2 in order to obtain a cell complex $\mathfrak{P}_{g,1}^m(G)$ that is homotopy equivalent to $\mathcal{M}_{g,1}^{(m)}(G)$. The main idea is to construct from every flat principal G -bundle over a Riemann surface the trivial principal G -bundle over the corresponding parallel slit domain. At the same time, this procedure can be reversed. Given suitable gluing functions for the trivial principal G -bundle over a parallel slit domain, a flat principal G -bundle over the corresponding Riemann surface can be constructed. To this end, let $\pi : E \rightarrow X$ be a principal G -bundle with flat connection form A and potential function $u : X \rightarrow \bar{\mathbb{R}}$. For the codimension one subspace $\mathcal{K}^* = \pi^{-1}(\mathcal{K})$ of E we have that the complement $E - \mathcal{K}^*$ is homeomorphic to the direct product of G and the corresponding parallel slit domain. On the other hand, let Y be the extended parallel slit domain with gluing functions $(\sigma_i)_i$ and which is subdivided into rectangles $R_{i,j}$ for $0 \leq i \leq q$ and

$0 \leq j \leq p$. Let $R_{i,j}^\xi$ be the rectangle $R_{i,j} \times \{\xi\}$ for $\xi \in G$ in $Y \times G$. For all pairs (i, j) choose elements $\gamma_{i,j} \in G$. Then the identification to reverse the Hilbert uniformization is as follows. The upper side of $R_{i,j}^\xi$ is glued to the lower side of $R_{i,\sigma_i(j)}^{\gamma_{i,j}\xi}$ and the left hand side of $R_{i,j}^\xi$ is glued to the right hand side of $R_{i+1,j}^\xi$. Again we need to impose conditions on $(\gamma_{i,j}, \sigma_i)_{i,j}$ (see Section 2.2) which characterize the cell complex $\mathfrak{P}_{g,1}^m(G)$. Consequently, we obtain a cell decomposition of $\mathcal{M}_{g,1}^{(m)}(G)$.

In fact, the precise implications of the Hilbert uniformization are rather stronger. Let $\mathfrak{H}_{g,1}^m(G)$ be the space of all equivalence classes $[E, \pi, X, A, u]$ where $[E, \pi, X, A] \in \mathcal{M}_{g,1}^{(m)}(G)$ and u is a potential function on X . By means of the properties of potential functions, it follows that $\mathfrak{H}_{g,1}^m(G) \rightarrow \mathcal{M}_{g,1}^{(m)}(G)$ is an affine bundle (see [9]). In particular, $\mathfrak{H}_{g,1}^m(G)$ and $\mathcal{M}_{g,1}^{(m)}(G)$ are homotopy equivalent and the following central result is satisfied (see Theorem 2.3.7).

Theorem. *The Hilbert uniformization defines a homeomorphism*

$$\mathcal{H}(G) : \mathfrak{H}_{g,1}^m(G) \rightarrow \mathfrak{P}_{g,1}^m(G).$$

Applying the cell decomposition the homology of some moduli spaces can be computed (see Example 2.3.9).

Example. For the moduli space $\mathcal{M}_{1,1}[2]_0$ of unramified, connected 2-sheeted coverings of the torus with one dipole point we have

$$H_n(\mathcal{M}_{1,1}[2]_0) \cong \begin{cases} \mathbb{Z}, & n = 0, 2 \\ \mathbb{Z}^2, & n = 1 \\ 0, & \text{else.} \end{cases}$$

Although the Hilbert uniformization provides a constructive method to calculate the homology difficulties arise nevertheless. These are due to the numerical complexity of the problem since the number of cells grows exponentially with larger g , m and G .

Still, the Hilbert uniformization has a further very interesting consequence. It is possible to identify a stratum of certain filtered bar complexes with a disjoint union of moduli spaces $\mathcal{M}_{g,1}^{(m)}(G)$. Namely, let G be a finite group of order $|G|$ that is realized as the subgroup of the symmetric group on $|G|$ elements $\mathfrak{S}_{|G|}$. Then the wreath product $G \wr \mathfrak{S}_p$ is a subgroup of $\mathfrak{S}_{|G|^p}$ for all $p \geq 0$. We consider the word length norm on $G \wr \mathfrak{S}_p$ with respect to all transpositions. Let $B(G \wr \mathfrak{S}_p)$ be the bar complex and let $\mathcal{F}_{(h)}B(G \wr \mathfrak{S}_p)$ consist of all elements of the bar complex whose product norm (with respect to the word length norm) equals $h \in \mathbb{N}$. Moreover, let $\mathcal{M}_{g,1}^{(m)}[|G|]^G$ be the moduli space of pointed, $|G|$ -sheeted unramified coverings with structure group G of Riemann surfaces of genus $g \geq 0$ with $m \geq 0$ permutable punctures and a directed base point. The Hilbert uniformization induces the homotopy equivalence (see Theorem 2.4.4)

$$\coprod_{h=|G|(2g+m)} \mathcal{M}_{g,1}^{(m)}[|G|]^G \longrightarrow \mathcal{F}_{(h)}B(G \wr \mathfrak{S}_*).$$

This result is in particular interesting with regard to the work of Visy [53]. By means of such norm filtrations, he set up complexes to compute the cohomology of so-called factorable groups. All groups in our statement are factorable with respect to the norm of the semidirect product induced by the trivial norm on G and the word length norm on the symmetric group. Therefore, a direct correspondence between geometric objects, the moduli spaces, and a purely algebraic concept, the cohomology of groups, is estab-

lished. Even more, it follows from our considerations that $\mathcal{F}_{(h)}B(G \wr \mathfrak{S}_*)$ is homeomorphic to a topological manifold (see Corollary 1.2.10).

Finally, we discuss another aspect of great impact in the present day investigations of moduli spaces. In the last chapter, we consider stabilization effects of $\mathcal{M}_{g,1}(G)$. The first important idea here goes back to Harer [30]. He showed using certain stabilization maps for the mapping class group $\Gamma_{g,n}$ that the homology $H_q(B\Gamma_{g,n})$ is independent of g and n for $g \gg 0$. Here $\Gamma_{g,n}$ denotes the mapping class group of a Riemann surface of genus $g \geq 0$ with $n \geq 0$ boundary components. By means of Harer's results, Tillmann proved that $\mathbb{Z} \times B\Gamma_{g,n}^+$ is an infinite loop space where $B\Gamma_{g,n}^+$ denotes the plus construction (see [50]). Both results were generalized in [17], [18] and [19] for moduli spaces of flat G -bundles. A central element is the definition of the stabilization maps. They are constructed by means of connected sums along boundary components. Note that the bundles of the sum are trivial on the boundary so that they can be identified canonically. Thus, from the base of the bundle, that is, the Riemann surface, arise stabilization maps. Moreover, there is a further stabilization map for certain choices of G . To this end, let $G = G(k)$ be one of the classical matrix groups $Sp(k)$, $SU(k)$ or $Spin(k)$. For the classifying spaces of these groups, Bott showed one of the first deep stabilization results (see [14]). Applying methods from [5] (see Theorem 3.2.1), it follows that the homotopy groups $\pi_q(\mathcal{M}_{g,1}(G(k)))$ do not depend on k for $k \gg 0$ (see Theorem 3.2.3).

Theorem. *Let X be a compact, oriented and connected surface of genus $g \geq 2$, then $\mathcal{R}i_k : \mathcal{R}_{G(k)}(X) \rightarrow \mathcal{R}_{G(k+1)}(X)$ is*

- (1) $(4k - 4)$ -connected for $G(k) = Sp(k)$.
- (2) $(2k - 2)$ -connected for $G(k) = SU(k)$.

(3) $(k - 3)$ -connected for $G(k) = Spin(k)$.

Moreover, we are in a position to calculate these stable homotopy groups explicitly (see Corollary 3.2.4).

Corollary. *Let $\mathop{\mathrm{hocolim}}_k \mathcal{R}_{G(k)}(X) = \mathcal{R}_\infty^G(X)$ for $G(k)$ being one of the classical families of connected, compact, semisimple Lie groups $Sp(k)$, $SU(k)$ or $Spin(k)$. The homotopy groups of $\mathcal{R}_\infty^G(X)$ are as follows.*

(1)

$$\pi_q(\mathcal{R}_\infty^{Sp}(X)) \cong \begin{cases} \mathbb{Z}, & q \equiv 0 \pmod{8} \\ 0, & q \equiv 1, 2 \pmod{8} \\ \mathbb{Z}^{2g}, & q \equiv 3, 7 \pmod{8} \\ (\mathbb{Z}/2)^{2g} \times \mathbb{Z}, & q \equiv 4 \pmod{8} \\ (\mathbb{Z}/2)^{2g+1}, & q \equiv 5 \pmod{8} \\ \mathbb{Z}/2, & q \equiv 6 \pmod{8}. \end{cases}$$

(2)

$$\pi_q(\mathcal{R}_\infty^{SU}(X)) \cong \begin{cases} \mathbb{Z}, & q \equiv 0 \pmod{2} \\ \mathbb{Z}^{2g}, & q \equiv 1 \pmod{2}. \end{cases}$$

(3)

$$\pi_q(\mathcal{R}_\infty^{Spin}(X)) \cong \begin{cases} (\mathbb{Z}/2)^{2g} \times \mathbb{Z}, & q \equiv 0 \pmod{8} \\ (\mathbb{Z}/2)^{2g+1}, & q \equiv 1 \pmod{8} \\ \mathbb{Z}/2, & q \equiv 2 \pmod{8} \\ \mathbb{Z}^{2g}, & q \equiv 3, 7 \pmod{8} \\ \mathbb{Z}, & q \equiv 4 \pmod{8} \\ 0, & q \equiv 5, 6 \pmod{8}. \end{cases}$$

The thesis is organized as follows. We introduce some foundations on flat connections on principal bundles in the first chapter. Moreover, we consider the topology of the moduli spaces and calculate homotopy and homology groups for the indicated examples. A large part is devoted to the characterization of connected components. In Section 1.5 we focus on moduli spaces of coverings by applying combinatorial methods. In the second chapter, the Hilbert uniformization is constructed. It is proven that it defines a homeomorphism from the space of flat G -bundles with potential function to a cell complex. Finally, a correspondence between a norm filtration and a disjoint union of moduli spaces is established in Section 2.4. In Section 2.5 we construct an H-space structure by means of parallel slit domains. Our considerations on this are based upon [10]. In the third chapter we deal with the stable topology of the moduli spaces and construct Dyer–Lashof operations in Section 3.1. In the last part of this thesis, the stable moduli spaces $\mathcal{M}_{g,1}(G(k))$ for $G(k) = Sp(k), SU(k), Spin(k)$ and $k \rightarrow \infty$ are examined. In particular, their stable homotopy groups are calculated.

Acknowledgements

In the first place, I want to acknowledge the Max Planck Institute for Mathematics for funding this thesis by a three year scholarship. I want to thank the Graduiertenkolleg 1150 “Homotopy and Cohomology” for the financial support on various occasions. Moreover, I am grateful to the Studienstiftung des deutschen Volkes for further support.

I want to express my thankfulness to Ralph Cohen and Søren Galatius for their invitation to Stanford University at the beginning of 2011. In particular, I am very grateful to Ralph Cohen for his continuous interest in my work. I want to thank Johannes Ebert for helpful conversations and advice on several topological questions. Special thanks go to the second referee of this thesis, Peter Teichner, for his feedback and great organizational support. Finally, I wish to express my gratitude to my supervisor Carl-Friedrich Bödigheimer who suggested this beautiful topic to me. I want to thank him for the encouragement, support and all his patience listening to me when I developed my ideas.

Chapter 1

Moduli spaces of flat G -bundles

1.1 Introduction to flat G -bundles

In this section we recall some fundamental definitions and properties of flat principal G -bundles. For a more detailed discussion we suggest [6].

Notation. Let $\pi : E \rightarrow M$ be a smooth principal G -bundle over a smooth manifold M for a fixed Lie group G . The transformation group G acts on E from the right. A principal G -bundle is denoted by (E, π, M) and we call it G -bundle for short. We use the notation $\{U_i, \phi_i\}$ for a bundle atlas and $\{U_i, g_{ij}\}$ for the corresponding transition functions. More precisely, these are smooth functions $g_{ij} : U_i \cap U_j \rightarrow G$ satisfying the cocycle condition such that $\phi_j \circ \phi_i^{-1}(x)$ is left multiplication on G with $g_{ij}(x)$ for all $x \in U_i \cap U_j$.

Definition 1.1.1. Let (E, π, M) be a smooth G -bundle and $T_v(E_x) \subseteq T_v E$ be the tangent space of the fiber E_x at the point $x \in M$ for $v \in E_x$. It is called the *vertical tangent space* of E at $v \in E$ and it is denoted by $TV_v E$. A complementary subspace is called a *horizontal tangent space*.

Definition 1.1.2. A *connection* on a G -bundle (E, π, M) is an assignment $TH : E \ni v \mapsto TH_v E \subseteq T_v E$, to a linear subspace of the tangent space, such

that the following conditions are satisfied.

(C1) For all $v \in E$ we have $TV_vE \oplus TH_vE = T_vE$.

(C2) For the right multiplication $R_g : E \rightarrow E$ by an element $g \in G$ holds

$$\forall v \in E, g \in G : dR_g(TH_vE) = TH_{vg}E.$$

(C3) For all $v \in E$ there exists a neighborhood $U \subseteq E$ and smooth local linearly independent vector fields s_1, \dots, s_k on U such that TH_wE is spanned by $\{s_1(w), \dots, s_k(w)\}$ for all $w \in U$.

In Definition 1.1.2 (C1) is the property of being *horizontal*, (C2) states *G-equivariance* and (C3) *smoothness* of a connection. Connections are central objects in the study of principal G -bundles from a differential view point. There are many ways to define connections on principal G -bundles. For this reason, we will introduce two further approaches which are equivalent to 1.1.2 and which will be helpful later.

Definition 1.1.3. Let L_g and R_g denote the left and right translation on G by the element $g \in G$, respectively. Each $g \in G$ defines a smooth homomorphism $\alpha_g = L_g \circ R_g^{-1} : G \rightarrow G$, that is, $\alpha_g(h) = ghg^{-1}$ for all $h \in G$. The conjugation induces a representation $Ad : G \rightarrow GL(\mathfrak{g})$ by $g \mapsto (\alpha_g)_*$, where \mathfrak{g} is the Lie algebra of G and $(\alpha_g)_*$ the induced map on \mathfrak{g} . It is called the *adjoint representation*.

For the adjoint representation we have $Ad(g)(X) = \left. \frac{d}{dt}(g \exp(tX)g^{-1}) \right|_{t=0}$ for all $X \in \mathfrak{g}$ and $g \in G$. In particular, $Ad(g)(X) = gXg^{-1}$ for matrix groups.

Definition 1.1.4. For a G -manifold E there is a map $\mathfrak{g} \rightarrow \mathfrak{X}(E)$, from the Lie algebra of G to the space of vector fields on E , defined by $X \mapsto \tilde{X}$ where

$\tilde{X}(v) = \frac{d}{dt}(v \exp(tX))|_{t=0}$ for all $v \in E$. We call \tilde{X} the *fundamental vector field* for X .

The equation $\pi_* \tilde{X}(v) = \frac{d}{dt} \pi(v \exp(tX))|_{t=0} = \frac{d}{dt} \pi(v) = 0$ holds for every G -bundle (E, π, M) . Hence, $X \mapsto \tilde{X}(v)$ defines an isomorphism $\mathfrak{g} \rightarrow TV_v E$ for each $v \in E$. Since the vertical and horizontal tangent space are complementary the differential $d\pi$ of π induces an isomorphism $d\pi_v : TH_v E \rightarrow T_{\pi(v)} M$. Bearing these geometric considerations in mind the following equivalent definition of a G -bundle connection can be established.

Definition 1.1.5. A *connection 1-form* A on a G -bundle (E, π, M) is a 1-form on E with values in \mathfrak{g} , that is, $A \in \Omega^1(E, \mathfrak{g})$, such that the following conditions are satisfied.

(CF1) For all $X \in \mathfrak{g}$ we have $A(\tilde{X}) = X$.

(CF2) For all $g \in G$ we have $R_g^* A = Ad(g^{-1}) \circ A$.

Theorem 1.1.6. *Connections are in one-to-one correspondence with connection forms for every G -bundle (E, π, M) .*

We do not present a proof of this theorem but just introduce the claimed bijection (see Section 3.1 of [6]). Let TH be a connection on E . Then for all $v \in E$, $X \in \mathfrak{g}$ and $\xi \in TH_v E$ a connection form is defined by the identity $A_v(\tilde{X}(v) \oplus \xi) = X$. On the other hand, let $A \in \Omega^1(E, \mathfrak{g})$ be a connection form on E . Then the assignment $TH : E \ni v \mapsto TH_v E = \ker(A_v)$ defines a connection on E .

Definition 1.1.7. Let (E, π, M) be a G -bundle, $A \in \Omega^1(E, \mathfrak{g})$ a connection form and $s : U \rightarrow E$ a local section of E . Then s induces the *local connection form* $A_s = A \circ ds \in \Omega^1(U, \mathfrak{g})$.

Let $\{U_i, s_i\}_i$ be a family of local sections of the principal G -bundle (E, π, M) and let $\{A_i \in \Omega^1(U_i, \mathfrak{g})\}_i$ be a family of local 1-forms such that

$$A_i = Ad(g_{ij}^{-1}) \circ A_j + \theta_{ij} \quad (*)$$

on all nonempty intersections $U_i \cap U_j$ where $\theta_{ij}(X) = dL_{g_{ij}^{-1}(x)}(dg_{ij}(X))$ for $X \in T_x(U_i \cap U_j)$.

Theorem 1.1.8. *For a fixed bundle atlas connection forms are in one-to-one correspondence with families of local connection forms satisfying $(*)$ for every G -bundle (E, π, M) .*

For a proof we refer to Section 3.1 of [6]. Following Theorems 1.1.6 and 1.1.8 a connection can be characterized by either 1.1.2, 1.1.5 or 1.1.7. For a G -bundle $\pi : E \rightarrow M$ with connection form A we write (E, π, M, A) . Moreover, we denote the set of all connection forms on E by $\mathcal{A}(E)$.

Definition 1.1.9. Let (E, π, M, A) be a smooth G -bundle with connection form A and let $\omega : [a, b] \rightarrow M$ be a path. We assume paths to be continuous and piecewise smooth. Then $\omega^* : [a, b] \rightarrow E$ is called a *horizontal lift* of ω if the following conditions are satisfied.

(HL1) For all $t \in [a, b]$ we have $\pi(\omega^*(t)) = \omega(t)$.

(HL2) For all $t \in [a, b]$ we have $\frac{d}{dt}\omega^*(t) \in TH_{\omega(t)}E$.

Following Section 2.3 in [36] for all $v \in E_{\omega(a)}$ exists a unique lift ω_v^* of ω such that $\omega_v^*(a) = v$.

Definition 1.1.10. Let (E, π, M, A) be a G -bundle with connection form A and let $\omega : [a, b] \rightarrow M$ be a path in M . The map $P_\omega^A : E_{\omega(a)} \rightarrow E_{\omega(b)}$ with $v \mapsto \omega_v^*(b)$ is called *parallel transport* in E along ω . We write P_ω for short if the connection is clear.

Geometrically, a parallel transport specifies how to compare fibers along a path ω (see Figure 1.1). Moreover, note that a parallel transport on a principal G -bundle (E, π, M) determines a connection uniquely (see Theorem 3.14 of [6]).

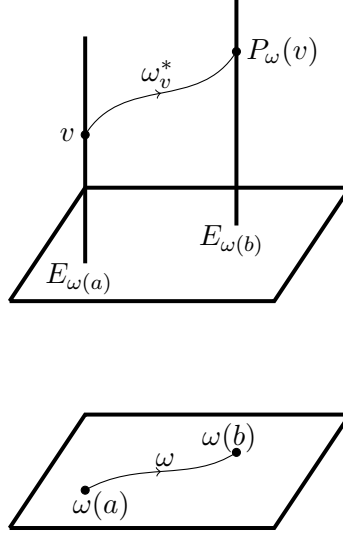

Figure 1.1: Parallel transport

Example 1.1.11. Let $(M \times G, \pi, M)$ be the trivial G -bundle with the trivial connection. The tangent space of a fiber at $(x, g) \in M \times G$ is isomorphic to the direct sum of tangent spaces $T_x M \oplus T_g G$. By definition, the horizontal tangent space is $T_x M$ while the vertical tangent space is $T_g G$. The trivial connection form $A_{(x,g)} : T_x M \oplus T_g G \rightarrow \mathfrak{g}$ is given by $X + Y \mapsto dL_{g^{-1}} Y$. Thus, the parallel transport for a path $\omega : [a, b] \rightarrow M$ is defined by $P_{\omega} : g \mapsto g$. In particular, it does not depend on the path ω .

Definition 1.1.12. Let (E, π, M) be a principal G -bundle. The *gauge group* $\mathfrak{G}(E)$ is the group of all G -equivariant maps $f : E \rightarrow E$ such that $\pi \circ f = \pi$. We define an action on $\mathfrak{G}(E)$ on $\mathcal{A}(E)$ from the left by pushforwards, that is, $(f, A) \mapsto f_* A$ for $f \in \mathfrak{G}(E)$ and $A \in \mathcal{A}(E)$. Let (E', π', M') be a principal G -

bundle with base point $x_0 \in M'$. The group of *pointed gauge transformations* $\mathfrak{G}_*(E')$ is the subgroup of $\mathfrak{G}(E')$ such that $f|_{E'_{x_0}}$ is the identity.

Note that the pushforward is well-defined since f is a diffeomorphism.

Definition 1.1.13. Let (E, π, M, A) be a principal G -bundle with connection form A . For every $x \in M$ we set

$$\Omega(x) = \{\omega : I \rightarrow M \text{ path} \mid \omega(0) = x = \omega(1)\}.$$

For $x \in M$ and $v \in E_x$ we define the *holonomy group* of A by

$$\text{Hol}_v(A) = \{g \in G \mid \exists \omega \in \Omega(x) : P_\omega^A(v) = vg\}.$$

Definition 1.1.14. We say that a principal bundle (E, π, M) admits a *flat structure* or simply that the bundle is *flat* if it has a connection A such that one of the following equivalent properties is satisfied.

- (1) The parallel transport P_ω depends only on the homotopy class of a path $\omega : [a, b] \rightarrow M$.
- (2) The bundle admits a trivialization of (E, π, M, A) over every simply-connected open subset of M such that A is trivial, i.e. as in 1.1.11.
- (3) There is a bundle atlas with locally constant transition functions.

The subset of all flat connections is denoted by $\mathcal{A}_F(E) \subseteq \mathcal{A}(E)$.

For a proof of the characterizations in 1.1.14 see Section 1.2 of [35]. As the parallel transport of a flat G -bundle depends only on the homotopy class of a path by (1) of 1.1.14 we are in a position to make the following definition.

Definition 1.1.15. Let (E, π, M, A) be a flat principal G -bundle with parallel transport P^A and let $x \in M$ and $v \in E_x$ be fixed base points. Then we define the *holonomy representation* $\rho_A : \pi_1(M, x) \rightarrow G$ by $P_\omega^A(v) = v\rho_A([\omega])$ for all $\omega \in \Omega(x)$. We write $\text{Hol}_v : \mathcal{A}_F(E) \rightarrow \text{Hom}(\pi_1(M, x), G)$ for the assignment $A \mapsto \rho_A$ and call it the *holonomy map* or *holonomy* for short.

We now explain how gauge equivalence classes of flat G -bundles are related to homomorphisms of the fundamental group of the base space to G .

Let M be a smooth and connected manifold with base point $x_0 \in M$. We write π_1 for the fundamental group $\pi_1(M, x_0)$. Moreover, let $\rho : \pi_1 \rightarrow G$ be a homomorphism and \tilde{M} the universal covering of M . Then \tilde{M} can be considered as a π_1 -bundle over M . The representation ρ defines an action of π_1 on $\tilde{M} \times G$ by $(\tilde{x}, g, \gamma) \mapsto (\tilde{x}\gamma, \rho(\gamma)^{-1}g)$ for all $\tilde{x} \in \tilde{M}$, $g \in G$ and $\gamma \in \pi_1$. Since π_1 acts properly and freely on \tilde{M} this also holds for $\tilde{M} \times G$. Thus, there is an associated G -bundle $\pi_\rho : E_\rho = \tilde{M} \times_\rho G \rightarrow M$.

Next we construct a flat connection for (E_ρ, π_ρ, M) . Let $p_2 : \tilde{M} \times G \rightarrow G$ be the canonical projection on the second factor. The differential defines a fiberwise linear map $dp_2 : T(\tilde{M} \times G) \rightarrow TG$. We consider the *Maurer–Cartan form* $\theta : TG \rightarrow \mathfrak{g}$. It is defined by $\theta(v) = dL_{g^{-1}}v$ for $v \in T_gG$ (see Definition 1.10 of [6]). Then $A_0 = \theta \circ dp_2$ is a flat connection form on the trivial bundle $\tilde{M} \times G \rightarrow \tilde{M}$. The left invariance of the Maurer–Cartan form (see Theorem 1.15 of [6]) implies that A_0 is also left invariant. Let $p : \tilde{M} \times G \rightarrow \tilde{M} \times_\rho G$ be the quotient map of the π_1 -action. Since A_0 is left invariant it defines a connection form $A_\rho \in \Omega^1(E_\rho, \mathfrak{g})$ by $p^*A_\rho = A_0$. More precisely, we have for $(\tilde{x}, g) \in \tilde{M} \times G$ and $v \in T_{(\tilde{x}, g)}(\tilde{M} \times G)$ that $A_\rho(\bar{v}) = A_0(v)$ where $p(\tilde{x}, g) = [\tilde{x}, g]$ and $\bar{v} = dp(v) \in T_{[\tilde{x}, g]}(\tilde{M} \times_\rho G)$.

Proposition 1.1.16. *The 1-form A_ρ is a flat connection form on the associated bundle (E_ρ, π_ρ, M) and satisfies $\text{Hol}(A_\rho) = \rho$.*

Proof. To show that A_ρ is a connection form we check only (CF1). (CF2) follows directly from the G -equivariance of θ with respect to the G -action from the right (see Theorem 1.15 of [6]). Since the pullback map p^* is linear it suffices to check (CF1) for A_0 . Let $X \in \mathfrak{g}$ with its fundamental vector field $\tilde{X} \in \mathfrak{X}(\tilde{M} \times G)$ and let $(\tilde{x}, g) \in \tilde{M} \times G$. Then

$$\begin{aligned} A_0(\tilde{X}) &= \theta \circ dp_2(\tilde{X}) = \theta \circ dp_2\left(\frac{d}{dt}(\tilde{x}, g) \exp(tX)|_{t=0}\right) \\ &= \theta\left(\frac{d}{dt}g \exp(tX)|_{t=0}\right) = X \end{aligned}$$

for θ is left invariant. As a consequence, A_ρ is a connection form.

For the flatness of A_ρ we apply (2) of 1.1.14. Let U be an open neighborhood of M such that $\tilde{M}|_U$ is trivial. Then $E_\rho|_U = (U \times \pi_1 \times G)/\pi_1 \cong U \times G$. It follows that $E_\rho|_U$ and $A_\rho|_U$ are trivial. Consequently, A_ρ is flat. For the last part we choose a base point $\tilde{x}_0 \in \tilde{M}_{x_0}$ of \tilde{M} and consider a loop α in M based in x_0 . Let $\tilde{\alpha}$ be the unique lift to \tilde{M} of α in \tilde{x}_0 . It defines a deck transformation $\tilde{M} \rightarrow \tilde{M}$ given by $\tilde{x} \mapsto \tilde{x}\alpha^{-1}$ where the concatenation corresponds to composition of paths. Let α^* be the parallel lift of α with respect to A_ρ with $\alpha^*(0) = [\tilde{x}_0, e]$ for $e \in G$ the identity element of G . More precisely, $\alpha^* = [\tilde{\alpha}, e] = p(\tilde{\alpha}, e)$. Then $\alpha^*(1) = [\tilde{\alpha}(1), e] = [\tilde{x}_0\alpha^{-1}, e] = [\tilde{x}_0, \rho([\alpha])]$. Consequently, the holonomy representation of A_ρ is ρ .

□

In the next lemma we will study the effect of base point changes. It is illustrated in Figure 1.2.

Lemma 1.1.17. *Let (E, π, M, A) be a flat principal G -bundle with base point $x_0 \in M$ and let $\alpha : I \rightarrow M$ be a path such that $\alpha(0) = x_0$ with end point $\alpha(1) = x_1$. We choose a base point $v_0 \in E_{x_0}$ and set $v_1 \in E_{x_1}$ for $P_\alpha^A(v_0)$. Let $\rho_i = \text{Hol}_{v_i}(A)$ for $i = 0, 1$.*

(1) For every $[\omega] \in \pi_1$ we have $\rho_1([\alpha\omega\alpha^{-1}]) = \rho_0([\omega])$.

(2) Let $g \in G$ and $\rho' = \text{Hol}_{v_0g}(A)$. Then $\rho' = g^{-1}\rho_0g$.

Proof. By Theorem 3.8 of [6] the parallel transport is G -equivariant and multiplicative with respect to the concatenation of paths. Thus, we have

$$(1) \quad v_1\rho_1([\alpha\omega\alpha^{-1}]) = P_{\alpha\omega\alpha^{-1}}^A(v_1) = P_\alpha^A P_\omega^A P_{\alpha^{-1}}^A(P_\alpha^A(v_0)) = P_\alpha^A(P_\omega^A(v_0)) \\ = P_\alpha^A(v_0)\rho_0([\omega]) = v_1\rho_0([\omega]).$$

$$(2) \quad P_\omega^A(v_0g) = P_\omega^A(v_0)g = v_0\rho_0([\omega])g = v_0g(g^{-1}\rho_0([\omega])g).$$

□

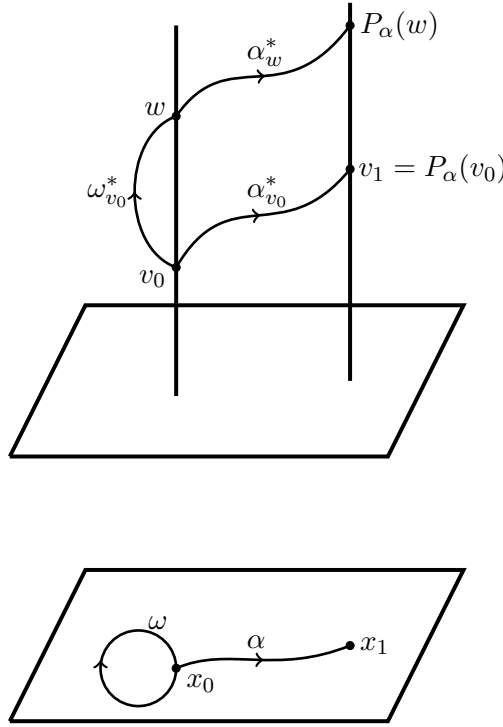

Figure 1.2: Parallel transport and change of base points

Lemma 1.1.18. Let (E, π, M, A) be a flat G -bundle with base points $x_0 \in M$ and $v_0 \in E_{x_0}$ and let $f \in \mathfrak{G}(E)$. Then $\rho_{f_*A} = g\rho_{AG}^{-1}$ for $g \in G$ defined by $f(v_0) = v_0g$.

Proof. Let $\alpha : [0, 1] \rightarrow M$ be a path and let $\alpha_{v_0, A}^*$ and α_{v_0, f_*A}^* be the unique horizontal lifts at v_0 with respect to A and f_*A , respectively. Applying the identity $P_\alpha^{f_*A} \circ f = f \circ P_\alpha^A$ (see Theorem 3.8 of [6]) it follows from the G -equivariance of the parallel transport that

$$\begin{aligned} v_0 \rho_{f_*A}([\alpha]) &= P_\alpha^{f_*A}(v_0) = f(P_\alpha^A(v_0))g^{-1} = f(v_0 \rho_A([\alpha]))g^{-1} \\ &= f(v_0)g^{-1}g\rho_A([\alpha])g^{-1} = v_0 g \rho_A([\alpha])g^{-1}. \end{aligned}$$

□

Corollary 1.1.19. *The pointed gauge group $\mathfrak{G}_*(E)$ acts trivially on the holonomy, that is, $\rho_{f_*A} = \rho_A$ for all $f \in \mathfrak{G}_*(E)$ and $A \in \mathcal{A}_F(E)$.*

Definition 1.1.20. Let M be a smooth and connected manifold with base point $x_0 \in M$. Its fundamental group $\pi_1(M, x_0)$ is denoted by π_1 . Define $\mathcal{H}(\pi_1, G)$ to be the category whose objects are homomorphisms from π_1 to G and whose morphisms are given by conjugation with elements of G . Further, let $\mathcal{H}_*(\pi_1, G)$ be the category having the same objects as $\mathcal{H}(\pi_1, G)$ but with identity morphisms only. We equip the set of objects of $\mathcal{H}(\pi_1, G)$ and $\mathcal{H}_*(\pi_1, G)$ with the compact-open topology. The set of morphisms of $\mathcal{H}(\pi_1, G)$ is by definition equal to the Lie group G .

Definition 1.1.21. Let M be a smooth and connected manifold and let $\text{Prin}(M, G)$ denote the set of equivalence classes of principal G -bundles over M . Let $\mathcal{C}(M, G)$ be the category whose set of objects is the disjoint union $\coprod_{[E]} \mathcal{A}_F(E)$ where $[E] \in \text{Prin}(M, G)$ denotes the equivalence class of a principal G -bundle E over M . A morphism between two objects of $\mathcal{C}(M, G)$ exists if there is a gauge transformation in the sense of Definition 1.1.12 between them. Analogously, we define the category $\mathcal{C}_*(M, G)$ of pointed flat G -bundles over M whose morphisms are given by the group action of the

pointed gauge group. We assume for $\mathcal{C}(M, G)$ and $\mathcal{C}_*(M, G)$ the discrete topology.

Theorem 1.1.22. *The holonomy map defines equivalences of categories $\mathcal{C}(M, G) \rightarrow \mathcal{H}(\pi_1, G)$ and $\mathcal{C}_*(M, G) \rightarrow \mathcal{H}_*(\pi_1, G)$.*

Proof. We first show that given two flat pointed G -bundles (E_i, π_i, M, A_i) for $i = 1, 2$ the set of their bundle isomorphisms is in one-to-one correspondence with elements $g \in G$ conjugating their holonomy representations ρ_i .

Let (E_i, π_i, M, A_i) be two flat pointed G -bundles over the same base space for $i = 1, 2$. We denote the base points by $x_0 \in M$ and $v_i \in E_{i, x_0}$. Let ρ_i be the holonomy representation of A_i at v_i and let P_i be the corresponding parallel transport for $i = 1, 2$. We will construct a bundle isomorphism $f : E_1 \rightarrow E_2$ such that $f_*A_1 = A_2$ and $f(v_1) = v_2$ under the assumption that $\rho_1 = \rho_2$. First note that by equivariance f has to satisfy $f(v_1g) = v_2g$ for all $g \in G$ so that f is determined on the fiber E_{1, x_0} .

To construct f on E_1 let $\alpha : I \rightarrow M$ be a path with $\alpha(0) = x_0$ and end point $\alpha(1) = x$. We set $f|_{E_{1, x}} = P_{2, \alpha} \circ f|_{E_{1, x_0}} \circ P_{1, \alpha^{-1}}$. This is well-defined for the following reason. Let ω be a loop based in x_0 . Then

$$P_{2, \omega} \circ f|_{E_{1, x_0}} \circ P_{1, \omega^{-1}}(v_1) = P_{2, \omega} \circ f|_{E_{1, x_0}}(v_1 \rho_1([\omega])^{-1}) = P_{2, \omega}(v_2 \rho_1([\omega])^{-1}) = v_2,$$

where the last equality follows from $\rho_1 = \rho_2$. Consequently,

$$P_{2, \omega} \circ f|_{E_{1, x_0}} \circ P_{1, \omega^{-1}}(v_1) = f|_{E_{1, x_0}}(v_1).$$

Two different paths starting in x_0 with end point x determine a loop and so $f|_{E_{1, x}}$ does not depend on the choice of α .

It remains to show that $f_*A_1 = A_2$. To this end, we apply characterization

(2) of Definition 1.1.14. Let $\alpha : I \rightarrow M$ be as before. We consider the parallel lift α_1^* with respect to A_1 in v_1 and write $\alpha_1^*(1) = v \in E_{1,x}$. Then $f \circ \alpha_1^*(1) = f(v)$ and $f \circ \alpha_1^*$ is the parallel lift of α with respect to f_*A_1 . Consequently,

$$P_\alpha^{f_*A_1} \circ f|_{E_{1,x_0}} \circ P_{1,\alpha^{-1}}(v) = P_\alpha^{f_*A_1}(f \circ \alpha_1^*(0)) = f \circ \alpha_1^*(1) = f(v). \quad (1.1)$$

To prove the assertion let U_1, \dots, U_n be open neighborhoods in M covering $\alpha([0,1])$ such that $A_i|_{U_j}$ is trivial for all $1 \leq j \leq n$ and $i = 1, 2$. We assume that the numbering of the open neighborhoods corresponds to the order of how α passes them. There is an isomorphism $h_j : E_1|_{U_j} \rightarrow E_2|_{U_j}$ for all $1 \leq j \leq n$ and $h_{j_*}A_1 = A_2$. By subdividing α with respect to the U_j we may assume that $h_j = h_{j+1}$ on the fiber of the respective subinterval end points. By equation (1.1) we have $f|_{(E_1|_{U_j})} = h_j$ and so the assumption follows.

Summarizing, we have shown that the holonomy map is surjective by Proposition 1.1.16. Injectivity follows since under the assumption $\rho_1 = \rho_2$ we have constructed a bundle isomorphism f such that $f_*A_1 = A_2$.

To finish the proof let E_1 and E_2 represent the same equivalence class $[E]$ and let f be an element of $\mathfrak{G}_*(E)$. Then, the theorem holds for $\mathcal{C}(M, G)_* \rightarrow \mathcal{H}_*(\pi_1, G)$ by Corollary 1.1.19. By Lemmas 1.1.17 and 1.1.18 the statement is also satisfied for $\mathcal{C}(M, G) \rightarrow \mathcal{H}(\pi_1, G)$.

□

Definition 1.1.23. Let S be a compact, oriented, connected surface and $\pi_1 = \pi_1(S, x_0)$ where $x_0 \in S$ is a fixed base point. Let G be a Lie group and let $\mathcal{R}_G(S)$ be all homomorphisms of π_1 to G equipped with the compact-open topology. We call $\mathcal{R}_G(S)$ the *representation variety* of S to G .

Let S be a compact, oriented, connected surface of genus $g \geq 0$ with $b \geq 0$

boundary components. We fix a generating set $\{A_i, B_i, C_j\}_{1 \leq i \leq g, 0 \leq j \leq b}$ of the fundamental group $\pi_1(S)$ of S such that $\prod_{1 \leq i \leq g} [A_i, B_i] \prod_{0 \leq j \leq b} C_j = 1$ where we assume C_0 to be trivial. A representation $\rho \in \mathcal{R}_G(S)$ is uniquely determined by its values on such a generating set $\{A_i, B_i, C_j\}_{1 \leq i \leq g, 0 \leq j \leq b}$. Hence, $\mathcal{R}_G(S)$ is a subset of G^{2g+b} . As a consequence, the topological properties of $\mathcal{R}_G(S)$ crucially depend on G . If G is a linear algebraic group then $\mathcal{R}_G(S)$ admits a structure of an algebraic set as the zero locus of a polynomial equation. We always assume G to be algebraic. In particular, $\mathcal{R}_G(S)$ is a real algebraic variety if G is a real linear algebraic group. Hence, it has finitely many components (see Section 2.3 of [26]). For semisimple Lie groups G the automorphism group of the Lie algebra is linear algebraic and the adjoint representation is a local isomorphism with finite kernel. Therefore, the representation variety is an algebraic variety. A special case are abelian groups G as in this case $\mathcal{R}_G(S) = G^{2g+b}$ admits the structure of a manifold induced from G . Moreover, it is a group with a smooth multiplication (see Example 1.1.24).

Example 1.1.24.

- (1) Let S be a closed, oriented, connected surface of genus $g \geq 0$. The representation variety for $G = \mathbb{R}$ is $\mathcal{R}_{\mathbb{R}}(S) \cong \mathbb{R}^{2g}$. If in addition a complex structure is given on S , that is, S is a Riemann surface X , then $\mathcal{R}_{\mathbb{R}}(X) \cong \mathbb{C}^g$ admits an induced complex structure as follows. By definition $\mathcal{R}_{\mathbb{R}}(X) = \text{Hom}(\pi_1(X), \mathbb{R})$ which is isomorphic to $H^1(X; \mathbb{R})$. The singular cohomology group $H^1(X; \mathbb{R})$ is isomorphic to the first de Rham cohomology $H_{\text{dR}}^1(X; \mathbb{R})$. Moreover, $H_{\text{dR}}^1(X; \mathbb{R})$ can be identified with the space of harmonic 1-forms $\mathcal{H}^1(X)$ (see page 100 in [29]). As $\mathcal{H}^1(X)$ admits the structure of a complex space there is an induced isomorphism $\mathcal{R}_{\mathbb{R}}(X) \cong \mathbb{C}^g$. We refer to Sections 2.2 and 7.1 of [28] for

all details.

- (2) Let X be a closed and connected Riemann surface of genus $g \geq 0$. Then $\mathcal{R}_{U(1)}(X) \cong H^1(X; \mathbb{R})/H^1(X; \mathbb{Z})$. As in (1) we identify $H^1(X; \mathbb{R})$ with $H_{\text{dR}}^1(X; \mathbb{R})$ so that $\mathcal{R}_{U(1)}(X)$ obtains an induced complex structure. Indeed, $H^1(X; \mathbb{R})/H^1(X; \mathbb{Z}) \cong \mathbb{R}^{2g}/\mathbb{Z}^{2g} = U(1)^{2g}$ is a $2g$ -dimensional torus. Because of the Abel–Jacobi construction this torus is exactly the Jacobi variety of X . Hence, we may conclude from Theorem 1.1.22 the well-known fact that flat line bundles over Riemann surfaces are parameterized by the Jacobi variety. See Section 2.2 in [29] for the Abel–Jacobi construction. Further, see Sections 3.2 and 7.1 of [28] for more details on this example.

Lemma 1.1.25 ([26]). *Let S be an oriented, compact and connected surface of genus $g \geq 0$ and let G be a connected Lie group with a covering $p : \tilde{G} \rightarrow G$. We consider the induced map $p_* : \mathcal{R}_{\tilde{G}}(S) \rightarrow \mathcal{R}_G(S)$ on the representation varieties. Then for each connected component K of the image of p_* the restriction $p_*|_{p_*^{-1}(K)} : p_*^{-1}(K) \rightarrow K$ is a covering with abelian deck transformation group $\mathcal{R}_{\ker(p)}(S)$.*

Proof. We assume that S is closed because the representation variety is just a direct product of Lie groups if the boundary of the surface is not empty. Then $\mathcal{R}_G(S) \cong \{(a_1, \dots, a_g, b_1, \dots, b_g) \in G^{2g} \mid \prod_i [a_i, b_i] = 1\}$. Let ξ be a point $(x_1, \dots, x_g, y_1, \dots, y_g) \in G^{2g}$ and $\xi(t) = (x_1(t), \dots, x_g(t), y_1(t), \dots, y_g(t))$ a path in $\mathcal{R}_G(S)$ such that $\xi(0) = \xi$. Moreover, let $\tilde{\xi} = (\tilde{x}_1, \dots, \tilde{x}_g, \tilde{y}_1, \dots, \tilde{y}_g)$ be in the fiber of ξ under p_* such that $\prod_i [\tilde{x}_i, \tilde{y}_i] = 1$, and $\prod_i [x_i, y_i] = 1$. Since \tilde{G} is a covering of G there is a unique lift $\tilde{\xi}(t)$ of $\xi(t)$ on to \tilde{G}^{2g} starting in $\tilde{\xi}(0) = \tilde{\xi}$. Then $p(\prod_i [\tilde{x}_i(t), \tilde{y}_i(t)]) = 1$ as p is a homomorphism, thus, $\tilde{\xi}(t) \subseteq \ker(p)^{2g}$. On the other hand, $\ker(p) \leq \pi_1(G)$ is discrete and,

consequently, $\tilde{\xi}(t)$ is constant. As we assumed $\prod_i [\tilde{x}_i, \tilde{y}_i] = 1$ it follows that $\prod_i [\tilde{x}_i(t), \tilde{y}_i(t)] = 1$. So the lift of $\xi(t)$ is a path of homomorphisms. It remains to check that p_* induces a covering with deck transformation group $\mathcal{R}_{\ker(p)}(S)$. For this let $\rho \in \mathcal{R}_{\tilde{G}}(S)$, $\kappa \in \mathcal{R}_{\ker(p)}(S)$ and $x, y \in \pi_1(S)$. Then

$$\kappa\rho(xy) = \kappa(xy)\rho(xy) = \kappa(x)\kappa(y)\rho(x)\rho(y) = \kappa(x)\rho(x)\kappa(y)\rho(y) = \kappa\rho(x)\kappa\rho(y),$$

because $\ker(p)$ is in the center of \tilde{G} . It follows that $\kappa\rho \in \mathcal{R}_{\tilde{G}}(S)$, so that $\mathcal{R}_{\ker(p)}(S)$ acts on $\mathcal{R}_{\tilde{G}}(S)$. Moreover, $p_*(\kappa\rho)(x) = p_*(\kappa(x))p_*(\rho(x)) = p_*(\rho(x))$, thus, p_* is invariant under the action of $\mathcal{R}_{\ker(p)}(S)$.

Now let $\rho_1, \rho_2 \in \mathcal{R}_{\tilde{G}}(S)$ such that $p_*(\rho_1) = p_*(\rho_2)$. As $\rho_1\rho_2^{-1}$ is in $\ker(p)$ there exists an element $\kappa \in \mathcal{R}_{\ker(p)}(S)$ with $\rho_1 = \kappa\rho_2$. So $\kappa(x) = \rho_1(x)\rho_2^{-1}(x)$ for all $x \in \pi_1$ and since $\ker(p)$ is abelian

$$\begin{aligned} \kappa(xy) &= \rho_1(xy)\rho_2^{-1}(xy) = \rho_1(x)\rho_1(y)\rho_2^{-1}(x)\rho_2^{-1}(y) = \\ &\rho_1(x)\rho_2^{-1}(x)\rho_1(y)\rho_2^{-1}(y) = \kappa(x)\kappa(y). \end{aligned}$$

□

We will mainly study smooth G -bundles or smooth complex G -bundles, that is, smooth real bundles with a complex structure. More precisely, let G be a Lie group such that there is a faithful real representation. For each principal G -bundle exists an associated smooth real vector bundle. If in addition the representation is complex there exists a complex bundle structure on the associated vector bundle, i.e. a fiberwise multiplication with $\sqrt{-1}$. This is equivalent for the fiber to be identified with a complex vector space. Such a bundle is called a complex vector bundle. On the other hand, we will consider G -bundles over Riemann surfaces and assume a holomorphic structure on the base space. Therefore, it is natural to ask for holomorphic structures

on the bundles. Note that a holomorphic vector bundle is defined by an atlas of biholomorphic transition functions (see Section 1.3 of [35]). If G is a compact and algebraic group it comes with a unitary faithful representation. Let $\rho : \pi_1 \rightarrow G$ be a homomorphism of the fundamental group of a connected complex manifold to G . Then the associated vector bundle to E_ρ inherits an induced Hermitian structure for the unitary representation of the structure group induces a Hermitian metric. In other words, we may just assume that the transition functions are unitary. The complexified vector bundle¹ E^c with structure group G^c over a Riemann surface carries an induced holomorphic structure (see Section 3.2 for further explanations).

All our constructions in Chapter 2 will work without assuming G to be compact. On the other hand, a deeper analysis of the moduli spaces often requires this property. We will encounter compact groups and holomorphic structures in Chapter 3.

1.2 Moduli spaces from a topological viewpoint

In this section we will introduce several moduli spaces which are the main objects of our study. An emphasis will be put on their topological properties.

Notation. Let $S_{g,n}^m$ be a closed, oriented and connected surface of genus $g \geq 0$ with $m \geq 0$ chosen points P_1, \dots, P_m (*marked points*) and with $n \geq 1$ *directed points* Q_1, \dots, Q_n , that is, points with nonzero tangent vectors $\chi_i \in T_{Q_i} S_{g,n}^m$.

We will call such directed points *dipole points* and fix Q_1 as the base point of the surface. It is assumed that marked points and dipole points are disjoint.

To lighten notation let $\mathcal{P} = \{P_1, \dots, P_m\}$ and $\mathcal{Q} = ((Q_1, \chi_1), \dots, (Q_n, \chi_n))$.

We denote by X a Riemann surface of topological type $S_{g,n}^m$.

¹The complexified vector bundle E^c is the associated bundle with structure group G^c (the complexification of G).

The term dipole point will be explained in Section 2.2 in connection with the Hilbert uniformization of Riemann surfaces. For further details see Section 3.1 of [9].

Definition 1.2.1. The *moduli space of Riemann surfaces* $\mathcal{M}_{g,n}^m$ consists of conformal equivalence classes of $S_{g,n}^m$. Two such surfaces X and X' are called *conformally equivalent* if there is a conformal homeomorphism $\phi : X \rightarrow X'$ such that $\phi(\mathcal{P}) = \mathcal{P}'$, $\phi(Q_i) = Q'_i$ and $d\phi(\chi_i) = \chi'_i$ for all $1 \leq i \leq n$. A point in $\mathcal{M}_{g,n}^m$ is denoted by $\mathcal{F} = [X, P_1, \dots, P_m, (Q_1, \chi_1), \dots, (Q_n, \chi_n)]$ or shortly by $[X, \mathcal{P}, \mathcal{Q}]$.

In Definition 1.2.1 $\mathcal{M}_{g,n}^m$ is just a set. Its topology will be introduced below (see Definition 1.2.4). Moreover, note that we assume in Definition 1.2.1 the marked points to be *permutable* while the dipole points are fixed pointwise by conformal homeomorphisms.

Definition 1.2.2. Let M be a smooth manifold with tangent bundle TM . An *almost complex structure* on M is a smooth section $J \in \Gamma(M, \text{End}(TM))$ of the endomorphism bundle over M such that $J^2 = -id$. A pair (M, J) is called an *almost complex manifold* and we denote by $\mathcal{S}(M)$ the set of all almost complex structures on M .

We always assume the conformal metric to be compatible with the complex structure. In the sequel, we consider the notions conformal and biholomorphic as being equivalent. Every complex structure induces an almost complex structure by multiplication with $\sqrt{-1}$ in the tangent space over every point of M . If M is a 2-dimensional manifold then the converse statement is also true. The set of all almost complex structures can be equipped with the C^∞ -topology and can be identified with the space of smooth sections of a $GL(2, \mathbb{R})/C^*$ -bundle over the surface M . So we will consider it as the space

of complex structures. For a more profound discussion see Chapter 2 of [22].

Definition 1.2.3. Let $Diff_{g,n}^m$ be the *diffeomorphism group* of $S_{g,n}^m$. It is given by all orientation preserving diffeomorphisms $f : S_{g,n}^m \rightarrow S_{g,n}^m$ such that $f(\mathcal{P}) = \mathcal{P}'$, $f(Q_i) = Q_i$ and $df(\chi_i) = \chi'_i$ for $1 \leq i \leq n$. With the \mathcal{C}^∞ -topology, $Diff_{g,n}^m$ is a topological group whose multiplication is the composition of two diffeomorphisms (see [22]).

Moreover, let $Diff_{g,n}^{m,0}$ denote the connected component of the identity of $Diff_{g,n}^m$. The quotient $\Gamma_{g,n}^m = Diff_{g,n}^m / Diff_{g,n}^{m,0}$ is called the *mapping class group* of $S_{g,n}^m$. The mapping class group is discrete.

The group $Diff_{g,n}^m$ acts on $\mathcal{S}(S_{g,n}^m)$ as follows. Let $J \in \mathcal{S}(S_{g,n}^m)$, $f \in Diff_{g,n}^m$ and $x \in S_{g,n}^m$ then $f.J_x \mapsto Tf^{-1}J_xTf$. According to Section 2.4 of [9] and [22] $Diff_{g,n}^m$ acts properly discontinuously and $Diff_{g,n}^{m,0}$ acts freely on $\mathcal{S}(S_{g,n}^m)$.

Definition 1.2.4. The *Teichmüller space* $\mathcal{T}_{g,n}^m$ and the *moduli space of Riemann surfaces* $\mathcal{M}_{g,n}^m$ are defined as the quotients

$$\begin{aligned}\mathcal{T}_{g,n}^m &= \mathcal{S}(S_{g,n}^m) / Diff_{g,n}^{m,0}, \\ \mathcal{M}_{g,n}^m &= \mathcal{S}(S_{g,n}^m) / Diff_{g,n}^m = \mathcal{T}_{g,n}^m / \Gamma_{g,n}^m.\end{aligned}$$

It was proven in [22] that the definitions presented in 1.2.1 and 1.2.4 are equivalent – we will use the same notation. In the sequel, it is assumed that the Teichmüller space and the moduli space are equipped with the quotient topology of the \mathcal{C}^∞ -topology on $\mathcal{S}(S_{g,n}^m)$. Moreover, $\mathcal{T}_{g,n}^m$ is homeomorphic to $\mathbb{R}^{6g-6+4n+2m}$ as a consequence of a theorem by Teichmüller. Therefore, the moduli space of Riemann surfaces with marked points and dipole points is a topological manifold of the indicated dimension (see also [1] for further details).

Next we will introduce another description of the Teichmüller space which is

equivalent to 1.2.4. For a discussion of the geometry of Teichmüller spaces see [33].

Definition 1.2.5. Let X be a Riemann surface of genus $g \geq 1$ with $m \geq 0$ marked points and a dipole (Q, χ) . A generating set $\mathcal{E} = \{A_i, B_i\}_{1 \leq i \leq g}$ of the fundamental group $\pi_1 = \pi_1(X, Q)$ satisfying the relation $\prod_{1 \leq i \leq g} [A_i, B_i] = 1$ is called a *marking*. Two Riemann surfaces with markings (X, \mathcal{E}) and (X', \mathcal{E}') are called equivalent if there exists a biholomorphic structure preserving map $\phi : X \rightarrow X'$ such that $\phi_*(\mathcal{E}) = \mathcal{E}'$. An equivalence class $[X, \mathcal{E}]$ is called a *marked Riemann surface*. The space of all marked Riemann surfaces is the *Teichmüller space* $\mathcal{T}_{g,1}^m$.

We do not make precise how to define the topology of the Teichmüller space when working with the notion from 1.2.5. For this we refer to Section 1.3 of [33]. The equivalence of Definition 1.2.4 and 1.2.5 is shown in the indicated reference.

Definition 1.2.6. Let (E, π, X, A) be a flat pointed G -bundle where X is a Riemann surface of genus $g \geq 0$ with $m \geq 0$ permutable marked points P_1, \dots, P_m and a dipole point (Q, χ) which is fixed as the base point. Moreover, let $p_0 \in E_Q$ be the base point of the total space. The moduli space $\mathcal{M}_{g,1}^m(G)$ consists of equivalence classes of smooth flat pointed G -bundles over Riemann surfaces with the above structure. Two flat pointed G -bundles $(E, \pi, X, A, \mathcal{P}, \mathcal{Q}, p_0)$ and $(E', \pi', X', A', \mathcal{P}', \mathcal{Q}', p'_0)$ are equivalent if the following conditions are satisfied. There exists a conformal homeomorphism $\phi : X \rightarrow X'$ such that $\phi(\mathcal{P}) = \mathcal{P}'$, $\phi(\mathcal{Q}) = \mathcal{Q}'$ and $d\phi(\chi) = \chi'$. Moreover, there is a fiber preserving diffeomorphism $f : E \rightarrow E'$ that satisfies $f(p_0) = p'_0$, $f_*A = A'$ and $\pi' \circ f = \phi \circ \pi$. We call $\mathcal{M}_{g,1}^m(G)$ the *moduli space of flat pointed G -bundles over Riemann surfaces with marked points*. A point

in $\mathcal{M}_{g,1}^m(G)$ is denoted by $[E, \pi, X, A, \mathcal{P}, \mathcal{Q}, p_0]$ which we usually abbreviate as $[E, \pi, X, A]$.

Definition 1.2.7. Let $\mathcal{T}_{g,1}^m(G)$ be the *Teichmüller space of flat G -bundles* over Riemann surfaces. It consists of equivalence classes of smooth flat pointed G -bundles over Riemann surfaces endowed with the combinatorial information as in Definition 1.2.4. Two such flat pointed G -bundles $(E, \pi, X, \mathcal{E}, A, p_0)$ and $(E', \pi', X', \mathcal{E}', A', p'_0)$ are called equivalent if the following conditions are satisfied. There is a structure preserving biholomorphic map $\phi : X \rightarrow X'$ such that $\phi_*(\mathcal{E}) = \mathcal{E}'$ and there is a fiber preserving pointed diffeomorphism $f : E \rightarrow E'$ with $f(p_0) = p'_0$, $f_*A = A'$ and $\pi' \circ f = \phi \circ \pi$.

The Teichmüller space $\mathcal{T}_{g,1}^m(G)$ and the moduli space $\mathcal{M}_{g,1}^m(G)$ parameterize the complex structure and the flat G -bundle structure. They differ analogously to $\mathcal{T}_{g,1}^m$ and $\mathcal{M}_{g,1}^m$. In order to define a natural topology on both spaces we have to study the topology of the Teichmüller space and the compact-open topology on the representation variety simultaneously.

Lemma 1.2.8. *The moduli space $\mathcal{M}_{g,1}^m(G)$ is, as a set, the fiber product $\mathcal{T}_{g,1}^m \times_{\Gamma_{g,1}^m} \mathcal{R}_G(S_{g,1}^m)$. Thus, it inherits the quotient topology of the direct product. The canonical projection $\Phi(G) : \mathcal{M}_{g,1}^m(G) \rightarrow \mathcal{M}_{g,1}^m$ given by $[E, \pi, X, A, \mathcal{P}, \mathcal{Q}, p_0] \mapsto [X, \mathcal{P}, \mathcal{Q}]$ is a fiber bundle with fiber $\mathcal{R}_G(S_{g,1}^m)$ and structure group $\Gamma_{g,1}^m$.*

Proof. We start with showing that $\mathcal{T}_{g,1}^m(G)$ is bijective to $\mathcal{T}_{g,1}^m \times \mathcal{R}_G(S_{g,1}^m)$. Then it remains to analyze the action of the mapping class group on this product. Let $[E, \pi, X, \mathcal{E}, A] \in \mathcal{T}_{g,1}^m(G)$ then there exists by Theorem 1.1.22 a unique flat G bundle $E_\rho \cong E$ on X with connection $A_\rho \cong A$ where $\rho = \text{Hol}(A)$. So we define an assignment $F : \mathcal{T}_{g,1}^m(G) \rightarrow \mathcal{T}_{g,1}^m \times \mathcal{R}_G(S_{g,1}^m)$ by $F : [E, \pi, X, \mathcal{E}, A] \mapsto ([X, \mathcal{E}], \rho)$. We need to verify that F is a bijection.

For surjectivity let $([X, \mathcal{E}], \rho) \in \mathcal{T}_{g,1}^m \times \mathcal{R}_G(S_{g,1}^m)$. Then by Section 1.1 there is a G -bundle $\pi_\rho : E_\rho \rightarrow X$ with flat connection A_ρ such that $[E_\rho, \pi_\rho, X, \mathcal{E}, A_\rho] \in \mathcal{T}_{g,1}^m(G)$. More precisely, $E_\rho = \tilde{X} \times_\rho G$ for the universal covering \tilde{X} of X .

In order to show that F is injective let $[E_i, \pi_i, X_i, \mathcal{E}_i, A_i] \in \mathcal{T}_{g,1}^m(G)$ for $i = 1, 2$ such that $F([E_1, \pi_1, X_1, \mathcal{E}_1, A_1]) = F([E_2, \pi_2, X_2, \mathcal{E}_2, A_2])$. We set $F([E_i, \pi_i, X_i, \mathcal{E}_i, A_i]) = ([X_i, \mathcal{E}_i], \rho_i)$ for $i = 1, 2$. Then there exists a biholomorphic map $\phi : X_1 \rightarrow X_2$ such that $\phi_*(\mathcal{E}_1) = \mathcal{E}_2$ where ϕ_* is the induced map on homotopy groups. Thus, $\rho_1 = \rho_2 \circ \phi_*$ for the representations. As a consequence of Theorem 1.1.22 it follows that $E_{\rho_1} \cong E_{\rho_2}$ and $A_{\rho_1} \cong A_{\rho_2}$. Since $E_i \cong E_{\rho_i}$ and $A_i \cong A_{\rho_i}$ (see Section 1.1) we have that F is injective.

The mapping class group acts on the representation variety as follows. Let $[f] \in \Gamma_{g,1}^m$, $\rho \in \mathcal{R}_G(S_{g,1}^m)$ and $\gamma \in \pi_1$, then $[f].\rho(\gamma) = \rho(f_*^{-1}(\gamma))$. Its action on the Teichmüller space is properly discontinuous by [22]. Hence, there is an action of $\Gamma_{g,1}^m$ on $\mathcal{T}_{g,1}^m \times \mathcal{R}_G(S_{g,1}^m)$ by $([f], [X, \mathcal{E}], \rho) \mapsto ([X, f_*(\mathcal{E})], [f].\rho)$ which induces an action of the mapping class group on the Teichmüller space of flat G -bundles by means of F . The canonical projection $\mathcal{T}_{g,1}^m(G) \rightarrow \mathcal{M}_{g,1}^m(G)$ just corresponds to this quotient. It follows that $\mathcal{M}_{g,1}^m(G)$ is bijective to $\mathcal{T}_{g,1}^m \times_{\Gamma_{g,1}^m} \mathcal{R}_G(S_{g,1}^m)$. Thus, we assume the induced topology of the direct product on $\mathcal{T}_{g,1}^m(G)$ and the induced quotient topology on $\mathcal{M}_{g,1}^m(G)$.

In the last step of the proof we have to analyze the group action of $\Gamma_{g,1}^m$. For this let $\Psi : \mathcal{T}_{g,1}^m(G) \rightarrow \mathcal{T}_{g,1}^m$ be the canonical projection. Then

$$[f].\Psi^{-1}([X, \mathcal{E}]) = \{([X, f_*(\mathcal{E})], [f].\rho) \mid \rho \in \mathcal{R}_G(S_{g,1}^m)\} = \Psi^{-1}([X, f_*(\mathcal{E})])$$

so that the action with $[f]$ is fiber preserving. Moreover,

$$\begin{aligned}\Psi([f].[E, \pi, X, \mathcal{E}, A]) &\cong \Psi([f].([X, \mathcal{E}], \rho)) = [X, f_*(\mathcal{E})] = [f].[X, \mathcal{E}] \\ &= [f].\Psi([X, \mathcal{E}], \rho) \cong [f].\Psi([E, \pi, X, \mathcal{E}, A]),\end{aligned}$$

where we apply the identification of $\mathcal{T}_{g,1}^m(G)$ with $\mathcal{T}_{g,1}^m \times \mathcal{R}_G(S_{g,1}^m)$. Since the projection Ψ is $\Gamma_{g,1}^m$ -equivariant it follows that $\Phi(G)$ is a bundle projection as stated. □

Remark 1.2.9. The projection $\Phi(G)$ of Lemma 1.2.8 possesses a section. More precisely, let $\rho_0 \in \mathcal{R}_G(S_{g,1}^m)$ be the trivial representation which maps any value of π_1 to the identity element $e \in G$. Then $\mathcal{M}_{g,1}^m \rightarrow \mathcal{M}_{g,1}^m(G)$ is given by a section $\mathcal{M}_{g,1}^m \rightarrow \mathcal{T}_{g,1}^m \times_{\Gamma_{g,1}^m} \mathcal{R}_G(S_{g,1}^m)$. More precisely, we define this section by $[X, \mathcal{P}, \mathcal{Q}] \mapsto [X, \mathcal{P}, \mathcal{Q}, \rho_0]$.

Corollary 1.2.10. *The moduli space $\mathcal{M}_{g,1}^m(G)$ admits the structure of a topological² manifold for any abelian or discrete and countable group G .*

Proof. Let $F \rightarrow E \rightarrow B$ be a fiber bundle, then E is a manifold if F and B are manifolds. The moduli space $\mathcal{M}_{g,n}^m$ is a manifold by [9], [23] and [49]. If G is abelian then $\mathcal{R}_G(S_{g,1}^m)$ is the product G^{2g} .

On the other hand, if G is discrete and countable so is $\mathcal{R}_G(S_{g,1}^m)$. Hence, $\mathcal{M}_{g,1}^m(G) \rightarrow \mathcal{M}_{g,1}^m$ is a covering. We will discuss this case in more detail in Section 1.5. □

So far, we have observed that $\mathcal{M}_{g,1}^m(G)$ is a topological manifold for a large class of groups G . Yet another natural topological problem is to ask for the

²For a topological manifold we assume that it is second countable, Hausdorff and locally homeomorphic to a Euclidean space.

classification or at least the number of connected components of a space. We will see that for many Lie groups G the solution methods for the case of genus $g \geq 2$ surfaces are different than for $g = 1$. So the torus case will be investigated separately in Section 1.3. Let $g \geq 2$ and let G be a Lie group such that $\pi_0(G)$ is abelian. This is for instance true for every semisimple and algebraic Lie group. Our first step will be the classification of connected components of $\mathcal{R}_G(S_{g,1}^m)$. Then it becomes possible to describe the connected components of the moduli spaces of flat G -bundles by studying the group action of the mapping class group. For this, we have to identify obstructions against triviality of the bundles.

First let G be a nonconnected Lie group and let $G \rightarrow \pi_0(G)$ be the map from G to its connected components. It induces a natural mapping $\text{Hom}(\pi_1, G) \rightarrow \text{Hom}(\pi_1, \pi_0(G)) \cong H^1(S_{g,1}^m; \pi_0(G))$ for which we set $\rho \mapsto o_1(\rho)$. So if G is for example $GL(n, \mathbb{R})$ or $O(n)$, then it has two components which are characterized by the sign of the determinant, i.e. by the orientation of the bundle E_ρ . So the first obstruction against the triviality of the bundle corresponds to the first Stiefel–Whitney class of the associated flat vector bundle to E_ρ .

If G is connected which implies $o_1(\rho) = 0$, then by classical obstruction theory there can be only the obstruction of lifting G to its universal cover \tilde{G} since a surface is a finite, compact 2-dimensional CW-complex. Let $\{A_i, B_i\}_{1 \leq i \leq g}$ be generators for π_1 as introduced in Section 1.1, $\rho \in \mathcal{R}_G(S_{g,1}^m)$ and $\tilde{\rho}(A_i), \tilde{\rho}(B_i)$ lifts to \tilde{G} . Then $\prod_i [\tilde{\rho}(A_i), \tilde{\rho}(B_i)]$ is an element of $\ker(\tilde{G} \rightarrow G) \cong \pi_1(G)$. As $\pi_1(G)$ is isomorphic to the group of deck transformations of the universal covering and is contained in the center of \tilde{G} it follows that the element $\prod_i [\tilde{\rho}(A_i), \tilde{\rho}(B_i)]$ is independent of the choice of a lift. We denote this product by $o_2(\rho)$ which is an element of $\pi_1(G) \cong H^2(S_{g,1}^m; \pi_1(G))$. Moreover, it is

invariant under the action of the mapping class group since $H^2(S_{g,1}^m; \pi_1(G))$ is generated by the orientation class of the surface. We have seen in Section 1.1 that $\mathcal{R}_G(S_{g,1}^m)$ is a real algebraic set for real algebraic groups G . Thus, it is locally contractible. As a consequence, $o_2(\rho)$ is locally constant and so it is an invariant of the connected components. In the forthcoming example it will be motivated that for a large class of groups $o_2(\rho)$ can be interpreted in terms of characteristic classes of the associated vector bundles to E_ρ .

Example 1.2.11. The obstruction $o_2(\rho)$ is the second Stiefel–Whitney class of the vector bundle associated to E_ρ for $G = SL(n, \mathbb{R})$ and $n \geq 3$. This is a direct consequence of the commutativity of the following diagram.

$$\begin{array}{ccccc}
 \pi_1 & \xrightarrow{\rho} & SL(n, \mathbb{R}) & \xrightarrow{r} & SO(n) \\
 & & \uparrow & & \uparrow \\
 & & \widetilde{SL}(n, \mathbb{R}) & \xrightarrow{\tilde{r}} & Spin(n) \\
 & & \uparrow & & \uparrow \\
 & & \pi_1(SL(n, \mathbb{R})) & \longrightarrow & \mathbb{Z}/2
 \end{array}$$

The two vertical sequences of the diagram are universal coverings. The horizontal arrow r is a retraction which is covered by a retraction \tilde{r} . Both retractions are not homomorphisms in contrast to all the other mappings in the diagram. The map of coefficients induces $H^2(S_{g,1}^m; \pi_1(SL(n, \mathbb{R}))) \rightarrow H^2(S_{g,1}^m; \mathbb{Z}/2)$, and maps $o_2(\rho)$ to the second Stiefel–Whitney class of its associated vector bundle. Geometrically, it is just the obstruction to the existence of a spin structure on the vector bundle.

In our previous discussion we followed [26] in many details. In this reference and in [38] the connected components of $\mathcal{R}_G(S_g)$ were described in terms of characteristic classes as in Example 1.2.11. Applying our considerations to these results we may summarize the number of connected components of

$\mathcal{M}_{g,1}^m(G)$ if $g \geq 2$ in the following table.

Lie group \mathbf{G}	Cardinality of $ \pi_0(\mathcal{M}_{\mathbf{g},1}^m(\mathbf{G})) $
$PSL(2, \mathbb{R})$	$4g - 3$
$SL(2, \mathbb{R})$	$2^{2g} + 2g - 3$
connected, compact, semisimple	$ \pi_1(G) $
connected, complex, semisimple	$ \pi_1(G) $

The first two results are a consequence of [26] where it is shown that o_2 defines a bijection between the connected components of the representation varieties and a range of Euler classes. Since the Euler class is invariant under orientation preserving diffeomorphisms the assumption follows by Lemma 1.2.8. The last two assertions of the table are a consequence of [38] where it was proven that o_2 establishes a bijection between the connected components of the representation varieties and $H^2(S_{g,1}^m; \pi_1(G))$. As the second cohomology is invariant under orientation preserving diffeomorphisms the assumption follows again by Lemma 1.2.8. Moreover, as a consequence of Theorem 0.4 of [38] the fundamental group of $\mathcal{M}_{g,1}^m(G)$ is isomorphic to $\Gamma_{g,1}^m$ for simply connected, semisimple and complex or compact Lie groups G , respectively. In these cases the representation variety is simply connected.

Remark 1.2.12. Let $H \subseteq G$ be a subgroup of a Lie group G . Then $\mathcal{R}_H(S_{g,1}^m) \rightarrow \mathcal{R}_G(S_{g,1}^m)$ is an embedding of a subspace induced from the inclusion $H^{2g} \rightarrow G^{2g}$. Therefore, $\mathcal{M}_{g,1}^m(H) \rightarrow \mathcal{M}_{g,1}^m(G)$ is an embedding of moduli spaces since the inclusion of the corresponding representation varieties is $\Gamma_{g,1}^m$ -equivariant. This fact is especially interesting when considering the inclusion of a compact into a noncompact Lie group. We will see such examples later.

1.3 Moduli spaces of flat G -bundles over tori

In this section we investigate flat G -bundles over closed Riemann surfaces X of genus $g = 1$. Then $\mathcal{R}_G(X)$ is isomorphic to $\{(a, b) \in G^2 | ab = ba\}$. As genus one surfaces are tori we will use T to denote the base space.

Lemma 1.3.1. *Let G be a Lie group such that each of its abelian subgroups is contained in a connected abelian subgroup. Then $\mathcal{M}_{1,1}^m(G)$ is connected.*

Proof. Let e_1, e_2 be two generators of \mathbb{Z}^2 , $\rho \in \mathcal{R}_G(T)$ and $\rho(e_i) = g_i$ for $i = 1, 2$. Since $g_1g_2 = g_2g_1$ there is a connected abelian subgroup A of G such that $g_i \in A$. So there exist smooth paths $\omega_i : I \rightarrow A$ with $\omega_i(0) = e$ and $\omega_i(1) = g_i$ for $i = 1, 2$ where $e \in G$ denotes the identity element of G . Then $\rho_t(e_i) = \omega_i(t)$ are two continuous paths in $\mathcal{R}_G(T)$ which define a homotopy from ρ to the trivial representation. Consequently, $\mathcal{R}_G(T)$ is connected and so is $\mathcal{M}_{1,1}^m(G)$.

□

Corollary 1.3.2. *If G is a Lie group whose maximal abelian subgroups are the maximal tori then $\mathcal{M}_{1,1}^m(G)$ is connected.*

Example 1.3.3. The Lie groups $U(n)$, $SU(n)$, $Sp(n)$ satisfy Corollary 1.3.2.

Theorem 1.3.4. *The representation variety $\mathcal{R}_{SO(3)}(T)$ consists of two connected components. These are characterized by the second Stiefel–Whitney classes of the associated vector bundles to the flat principal $SO(3)$ -bundles E_ρ for $\rho \in \mathcal{R}_{SO(3)}(T)$. More precisely, the component I_0 of the trivial representation ρ_0 is associated with the trivial Stiefel–Whitney class. The other component I_1 contains only representations ρ such that the second Stiefel–Whitney class of the associated vector bundle to E_ρ is nontrivial. The fundamental group of I_0 is isomorphic to $\mathbb{Z}/2 \times \mathbb{Z}/2$.*

Proof. First we analyze the connected components of $\mathcal{R}_{SO(3)}(T)$. In a second step, we will calculate the fundamental group $\pi_1(I_0)$ of the component I_0 containing the trivial representation $\rho_0 \in \mathcal{R}_{SO(3)}(T)$. Let $V(2, 3)$ be the Stiefel manifold of orthonormal 2-frames in the 3-dimensional Euclidean space. Note that $SO(3)$ and $V(2, 3)$ are homeomorphic.

We start with showing that the representation variety $\mathcal{R}_{SO(3)}(T)$ has exactly two connected components and is homeomorphic to $I_0 \dot{\cup} (V(2, 3)/\mathbb{Z}/2 \times \mathbb{Z}/2)$. The action of $(\mathbb{Z}/2)^2$ on $V(2, 3)$ is given by $((x_1, x_2), (\epsilon_1, \epsilon_2)) \mapsto (\epsilon_1 x_1, \epsilon_2 x_2)$ for $x_i \in \mathbb{R}^3$, $\epsilon_i \in \mathbb{Z}/2$ and $i = 1, 2$, while (x_1, x_2) denotes a 2-frame in \mathbb{R}^3 .

The group $SO(3)$ can be considered as the rotation group of \mathbb{R}^3 . Let $x \in \mathbb{R}^3$ and let $\langle x \rangle \subseteq \mathbb{R}^3$ be the linear subspace spanned by the vector x . We denote a rotation about an angle $\alpha \in [0, 2\pi[$ with rotation axis $\langle x \rangle$ by $D(\alpha, x)$. Every nontrivial rotation $D(\alpha, x)$ is uniquely determined by its rotation angle α and its rotation axis $\langle x \rangle$ (this is Euler's theorem). We denote the identity element of $SO(3)$ by e . Further, $SO(3)$ is in one-to-one correspondence with the following quotient of $D = [0, 2\pi[\times (\mathbb{R}^3 - \{0\})$. We divide by an equivalence relation \sim which is defined by $(\alpha, x) \sim (\beta, y)$ if $\alpha = \beta = 0$ or if $\alpha = \beta \neq 0$ and $\langle x \rangle = \langle y \rangle$. An equivalence class is denoted by $[\alpha, x]$. In addition, we write $[0]$ if $\alpha = 0$. In particular, $[0, x] = [0]$ for all $x \in \mathbb{R}^3 - \{0\}$. In other words, the set of representatives of $[0]$ consists of all pairs $(0, x)$ for $x \in \mathbb{R}^3 - \{0\}$. Then there is a bijection $F : SO(3) \rightarrow D/\sim$ by mapping a nontrivial rotation about the angle $\alpha \neq 0$ which fixes a linear subspace $\langle x \rangle \subseteq \mathbb{R}^3 - \{0\}$ to $[\alpha, x]$. Finally, the identity element e is mapped to $[0]$ by F . Moreover, F defines a homeomorphism since D/\sim is homeomorphic to the quotient of the solid ball of radius π in \mathbb{R}^3 whose antipodal points are identified. But this is the real projective space $\mathbb{R}\mathbb{P}^3$ which is homeomorphic to $SO(3)$. Thus, we may identify every element of $SO(3)$ with an equivalence

class in D/\sim .

According to [3] (see the proof of Proposition 3.1) two rotations $D(\alpha, x)$ and $D(\beta, y)$ about nontrivial rotation axis commute if and only if one of the following properties is satisfied.

(C1) $\langle x \rangle$ equals $\langle y \rangle$.

(C2) $\langle x \rangle$ is perpendicular to $\langle y \rangle$ and $\alpha = \beta = \pi$.

Two elements $a, b \in SO(3)$ commute if and only if there are commuting rotations $D(\alpha, x)$ and $D(\beta, y)$ such that $F(a) = [\alpha, x]$ and $F(b) = [\beta, y]$. In view of the identification defined by F , we say that a and b satisfy (C1) or (C2). If $a = e$ or $b = e$ then (C1) is satisfied since $[0]$ is represented by rotations $D(0, x)$ for any $x \in \mathbb{R}^3 - \{0\}$.

In order to show that $\mathcal{R}_{SO(3)}(T)$ has exactly two connected components it remains to verify that all pairs satisfying (C1) are contained in I_0 while all pairs satisfying (C2) lie in I_1 . Let $a, b \in SO(3)$ such that $F(a) = [\alpha, x]$ and $F(b) = [\beta, y]$ with $\langle x \rangle = \langle y \rangle$. Then there are continuous paths $(\alpha_t)_{t \in I}, (\beta_t)_{t \in I} \subseteq [0, 2\pi[$ such that $\alpha_0 = \alpha, \beta_0 = \beta$ and $\alpha_1 = \beta_1 = 0$. Namely, $\alpha_t = \alpha(1-t)$ and $\beta_t = \beta(1-t)$. Let $(r_t)_{t \in I}$ be a continuous path in $\mathbb{R}^3 - \{0\}$ such that $\langle r_0 \rangle = \langle x \rangle = \langle y \rangle$. Then there is a path $(a_t, b_t)_{t \in I} \subseteq SO(3)^2$ with $F(a_t) = [\alpha_t, r_t]$ and $F(b_t) = [\beta_t, r_t]$ which satisfy $(F(a_t), F(b_t)) = ([0], [0])$ and $a_t b_t = b_t a_t$ for all $t \in I$.

On the other hand, the set of all pairs $(a, b) \in SO(3)^2$ satisfying (C2) is homeomorphic to $V(2, 3)/\mathbb{Z}/2 \times \mathbb{Z}/2$. To this end, let $F(a) = [\pi, x]$ and $F(b) = [\pi, y]$. Then $\langle x \rangle$ is perpendicular to $\langle y \rangle$ and so $(x, y) \in V(2, 3)$. Since, $[\pi, -r] = [\pi, r]$ for any $r \in \mathbb{R}^3 - \{0\}$ and $V(2, 3)$ is connected it follows that its quotient by $\mathbb{Z}/2 \times \mathbb{Z}/2$ is connected and homeomorphic to I_1 .

In the next step we analyze the connected components I_1 and I_0 . The real

algebraic Lie group $SO(3)$ is connected, compact and simple. The torus is a closed 2-dimensional CW-complex. Consequently, there remains only one possibly nontrivial obstruction against the triviality of a principal $SO(3)$ -bundle over T . More precisely, the only possibly nontrivial characteristic class of a vector bundle associated to an $SO(3)$ -bundle over the torus is the second Stiefel–Whitney class. Let $\rho_1, \rho_2 \in \mathcal{R}_{SO(3)}(T)$ be two representations contained in the same connected component. By Proposition 4.2 of [48] E_{ρ_1} and E_{ρ_2} are topologically isomorphic. In particular, their second Stiefel–Whitney classes are equal. As a consequence, to classify the connected components I_0 and I_1 it is sufficient to consider representatives from each of them. For the trivial representation $\rho_0 \in I_0$ we have that the associated vector bundle to E_{ρ_0} is trivial (see Example 1.1.11). Thus, the second Stiefel–Whitney classes of the associated vector bundles to E_ρ for any $\rho \in I_0$ are trivial. Let e_1 and e_2 be generators of $\pi_1(T)$ as introduced in Section 1.1 and let $\rho \in I_1$ be the representation whose values on these generators are given by

$$a_1 = \rho(e_1) = \begin{pmatrix} \cos(\pi) & -\sin(\pi) & 0 \\ \sin(\pi) & \cos(\pi) & 0 \\ 0 & 0 & 1 \end{pmatrix}$$

which is a rotation about π and the z -axis, and

$$a_2 = \rho(e_2) = \begin{pmatrix} \cos(\pi) & 0 & -\sin(\pi) \\ 0 & 1 & 0 \\ \sin(\pi) & 0 & \cos(\pi) \end{pmatrix}$$

which is a rotation about π and the y -axis.

By our previous considerations a_1 and a_2 satisfy (C2). Since a_i^2 equals the

identity matrix for $i = 1, 2$, the holonomy group of E_ρ has a reduction to $\mathbb{Z}/2$. Applying a_1 and a_2 there are transformations of \mathbb{R}^3 into $\mathbb{R} \oplus \mathbb{R}^2$ with respect to the standard Euclidean basis. We have to consider the weights of the induced representation $SO(3) \rightarrow SO(2)$ (see Section 5.4 in [46]). As $SO(2)$ is isomorphic to $U(1)$ we will consider \mathbb{R}^3 as $\mathbb{R} \oplus \mathbb{C}$. Moreover, let us consider $\mathbb{Z}/2$ as the multiplicative group consisting of two elements ϵ_1, ϵ_2 . Since the calculation depends on the homomorphism $\mathbb{Z}/2 \rightarrow U(1)$ we consider all possible maps which are defined by $\epsilon_1 \mapsto \exp(\sqrt{-1}n\pi)$ for n even, and $\epsilon_2 \mapsto \exp(\sqrt{-1}m\pi)$ for m odd. The weights of the representations are the well-known values $(0, 2k + 1)$ for $m = 2k + 1$ and $k \in \mathbb{Z}$. From Section 9 in [13] it follows that

$$c = (1 + (2k_1 + 1)t)(1 + (2k_2 + 1)t) = 1 + (2k_1 + 1)(2k_2 + 1)t^2 + 2(k_1 + k_2 + 1)t$$

for the Chern class c of the associated vector bundle to E_ρ . Therefore, $c \equiv 1 + t^2$ modulo 2 so that the second Stiefel–Whitney class is nontrivial. Note that we interpret c as an elementary symmetric function. Summarizing, we may characterize the two connected components of the representation variety by the second Stiefel–Whitney classes of the associated 3-dimensional vector bundles.

Now we will calculate the fundamental group of I_0 . Note that I_0 is homeomorphic to $S^2 \times S^1 \times S^1 / \sim$ where \sim is the identification $(r, \lambda, \mu) \sim (-r, \bar{\lambda}, \bar{\mu})$ and $(r, 1, 1) \sim (r', 1, 1)$ for $r, r' \in S^2$ and $\lambda, \mu \in S^1$. Here $\bar{\lambda}$ is the complex conjugate of λ . Let $[r, \lambda, \mu]$ be the equivalence class of (r, λ, μ) with respect to \sim . Set $S = S^1 \times S^1 - \{(1, 1)\}$ and let I' be the complement of the point

$[r, 1, 1]$ in I_0 . There is a free $\mathbb{Z}/2$ -action on $S^2 \times S^1$ by

$$(\epsilon, (r, \lambda, \mu)) \mapsto (\epsilon r, \epsilon \lambda, \epsilon \mu) = \begin{cases} (r, \lambda, \mu), & \text{if } \epsilon = 1 \\ (-r, \bar{\lambda}, \bar{\mu}), & \text{if } \epsilon = -1. \end{cases}$$

Therefore, $\mathbb{Z}/2 \rightarrow S^2 \times S \rightarrow I'$ is a covering. It induces a short exact sequence of homotopy groups

$$0 \rightarrow \pi_1(S^2 \times S) \rightarrow \pi_1(I') \rightarrow \mathbb{Z}/2 \rightarrow 0. \quad (1.2)$$

The short exact sequence is split because the injection $S^2 \rightarrow S^2 \times S$ with respect to the base point $(-1, -1) \in S$ and the projection $S^2 \times S \rightarrow S^2$ are $\mathbb{Z}/2$ -equivariant. Moreover, the composition of this injection and this projection is the identity and \mathbb{RP}^2 is a retract of I' . So the assertion follows from the commutativity of diagram

$$\begin{array}{ccccc} \mathbb{Z}/2 & \xlongequal{\quad} & \mathbb{Z}/2 & \xlongequal{\quad} & \mathbb{Z}/2 \\ \downarrow & & \downarrow & & \downarrow \\ S^2 & \longrightarrow & S^2 \times S & \longrightarrow & S^2 \\ \downarrow & & \downarrow & & \downarrow \\ \mathbb{RP}^2 & \longrightarrow & I' & \longrightarrow & \mathbb{RP}^2. \end{array}$$

By construction, $\pi_1(S^2 \times S)$ is isomorphic to the free product $\mathbb{Z} * \mathbb{Z}$. As a consequence of the $\mathbb{Z}/2$ -action on $S^2 \times S$ as defined above $\pi_1(I')$ has a representation as $\langle A, B, C \mid A^{-1} = A^C, B^{-1} = B^C, C^2 = 1 \rangle$.

We are now in a position to determine $\pi_1(I_0)$. For this we identify S^1 with the quotient of $\{\exp(\sqrt{-1}\theta) \mid \theta \in [-\pi, \pi]\}$ where $\exp(\sqrt{-1}\pi)$ and $\exp(-\sqrt{-1}\pi)$ are identified. Let $U = \{\exp(i\theta) \mid \theta \in]-\frac{\pi}{2}, \frac{\pi}{2}[\}$ so that U is invariant under complex conjugation and contractible. Then $U \times U$ is a contractible

neighborhood of $(1, 1)$ in $S^1 \times S^1$. It follows that $V = S^2 \times U \times U / \sim$ is contractible. Namely, let $p_N \in S^2$ be the north pole and let $[r, \lambda, \mu] \in V$ such that $\lambda = \exp(\sqrt{-1}\theta)$ and $\mu = \exp(\sqrt{-1}\vartheta)$ for some $\theta, \vartheta \in]-\frac{\pi}{2}, \frac{\pi}{2}[$. Then $H_t([r, \lambda, \mu]) = [\frac{r(1-t)+tp_N}{|r(1-t)+tp_N|}, \exp(\sqrt{-1}\theta(1-t)), \exp(\sqrt{-1}\vartheta(1-t))]$ defines a homotopy from the identity to the constant map equal to $[p_N, 1, 1]$. Moreover, note that $I_0 = I' \cup V$. We will examine the intersection $V \cap I'$ in order to apply the theorem of Seifert–van Kampen. By construction, this intersection is $S^2 \times U \times U / \sim -\{[r, 1, 1]\}$. Thus, it is homotopy equivalent to $S^2 \times S^1 / (r, \lambda) \sim (-r, \bar{\lambda})$. But this quotient is exactly $S^2 \times S^1 / \mathbb{Z}/2$ for which we have already checked that the $\mathbb{Z}/2$ -action is free. Consequently, the short exact sequence

$$0 \rightarrow \mathbb{Z} \rightarrow \pi_1(S^2 \times S^1 / \mathbb{Z}/2) \rightarrow \mathbb{Z}/2 \rightarrow 0 \quad (1.3)$$

implies $\pi_1(V \cap I') \cong \mathbb{Z}$. Let $i_V : V \rightarrow I_0$, $i_{I'} : I' \rightarrow I_0$ and $i_{V I'} : V \cap I' \rightarrow I_0$ be the natural inclusions. Moreover, let $j : I' \cap V \rightarrow I'$ be the natural inclusion so that $i_{V I'} = i_{I'} \circ j$. We fix a generator z of $\pi_1(V \cap I')$, then $i_{I'_*} \circ j_*(z) = 1$ because V is contractible. From the short exact sequences (1.2) and (1.3) we obtain the commutative diagram:

$$\begin{array}{ccccccc} 0 & \longrightarrow & \mathbb{Z} & \xrightarrow{f_1} & \pi_1(I' \cap V) & \xrightarrow{f_2} & \mathbb{Z}/2 \longrightarrow 0 \\ & & \downarrow h_1 & & \downarrow h_2 & & \downarrow = \\ 0 & \longrightarrow & \mathbb{Z} * \mathbb{Z} & \xrightarrow{g_1} & \pi_1(I') & \xrightarrow{g_2} & \mathbb{Z}/2 \longrightarrow 0. \end{array} \quad (1.4)$$

Let $x \in \mathbb{Z}$ be a fixed generator. Then $h_1(x) = [A, B]$ for a generating set $\{A, B\}$ of $\mathbb{Z} * \mathbb{Z}$ and $f_1(x) = x^2$. Note that $h_2 = j_*$ and let y be a chosen generator of $\pi_1(V \cap I')$. Then $h_2(y)^2 = [A, B]$ by commutativity of the left square in Diagram (1.4). Moreover, we have $f_2(y) = \epsilon$ for $\langle \epsilon \rangle = \mathbb{Z}/2$ and

so $g_2(h_2(y)) = \epsilon$. But $j_*(y)$ is of the form $A^{\alpha_1}B^{\beta_1} \dots A^{\alpha_p}B^{\beta_p}\epsilon$ and $j_*(y)^2$ is $A^{\alpha_1}B^{\beta_1} \dots A^{\alpha_p}B^{\beta_p}A^{-\alpha_1}B^{-\beta_1} \dots A^{-\alpha_p}B^{-\beta_p}$. Hence, $j_*(y)^2 = ABA^{-1}B^{-1}$ if and only if $p = 1$, $\alpha_1 = 1$ and $\beta_1 = 1$. As Diagram (1.4) commutes we obtain the relations for $\pi_1(I_0)$ by the theorem of Seifert–van Kampen, that is, $\langle A, B, C | A^C = A^{-1}, B^C = B^{-1}, C^2 = 1, ABC = 1 \rangle$. This group is isomorphic to $\mathbb{Z}/2 \times \mathbb{Z}/2$. It is a well-known representation of the Klein four-group.

□

We are in a position to say more about the connected component I_1 . Its fundamental group is isomorphic to the quaternionic group Q . This is a consequence of the geometric characterization given in the beginning of the proof of Theorem 1.3.4. More precisely, the space $V(2, 3)/(\mathbb{Z}/2)^2$ is homeomorphic to S^3/Q . Since $Q \rightarrow S^3 \rightarrow S^3/Q$ is the universal covering of S^3/Q it follows that $\pi_1(I_1) = Q$. We refer to Proposition 6 of [25] for all further details on this computation.

Theorem 1.3.5. *The moduli space $\mathcal{M}_{1,1}^m(SO(3))$ consists of two connected components which are characterized by the second Stiefel–Whitney classes of the associated vector bundles to the principal $SO(3)$ -bundles. More precisely, one component consists of topologically trivial bundles while the other component contains bundles with a nontrivial second Stiefel–Whitney class. The fundamental group of the connected component containing the trivial bundle is isomorphic to $(\mathbb{Z}/2)^2 \rtimes \Gamma_{1,1}^m$.*

Proof. By Lemma 1.2.8 $\mathcal{R}_{SO(3)}(T) \rightarrow \mathcal{M}_{1,1}^m(SO(3)) \rightarrow \mathcal{M}_{1,1}^m$ is a fiber bundle whose structure group is the mapping class group $\Gamma_{1,1}^m$. Thus, we can calculate $\pi_0(\mathcal{M}_{1,1}^m(SO(3)))$ by means of the long exact sequence of homotopy groups. Since $\mathcal{M}_{1,1}^m$ is connected it remains to study the group action of

$\Gamma_{1,1}^m$ on the two components of $\mathcal{R}_{SO(3)}(T)$ (see Theorem 1.3.4) to determine $\pi_0(\mathcal{M}_{1,1}^m(SO(3)))$.

In Theorem 1.3.4 we established a one-to-one correspondence between $\pi_0(\mathcal{R}_{SO(3)}(T))$ and the Stiefel–Whitney classes of the associated vector bundles to E_ρ for $\rho \in \mathcal{R}_{SO(3)}(T)$. Let $\rho \in \mathcal{R}_{SO(3)}(T)$ and let V_ρ be the associated vector bundle to E_ρ . The mapping class group acts by means of orientation preserving diffeomorphisms. Thus, for any $[f] \in \Gamma_{1,1}^m$ we have $w_2(V_\rho) = f^*w_2(V_\rho) = w_2(f^*V_\rho)$. Note that this equation is well-defined as V_ρ is a vector bundle over the torus. The last equality is a consequence of the naturality of characteristic classes. But by construction of E_ρ in Section 1.1 f^*V_ρ and $V_{[f].\rho}$ are isomorphic vector bundles so that $w_2(V_\rho) = w_2(V_{[f].\rho})$. It follows that I_0 and I_1 are invariant under the action of the mapping class group, that is, for $j = 0, 1$, any $[f] \in \Gamma_{1,1}^m$ and $\rho \in I_j$ we have that $[f].\rho \in I_j$. As a consequence, $\mathcal{M}_{1,1}^m(SO(3))$ has two connected components. One component consists of topologically trivial bundles while the other component contains bundles whose associated vector bundles have a nontrivial Stiefel–Whitney class.

The assertion on the fundamental group of the moduli space follows from Theorem 1.3.4 and the long exact sequence of homotopy groups since the bundle projection $\Phi(SO(3))$ possesses a section by Remark 1.2.9.

□

Corollary 1.3.6.

- (1) *The map $\Phi(SU(2))_* : \pi_1(\mathcal{M}_{1,1}^m(SU(2))) \rightarrow \pi_1(\mathcal{M}_{1,1}^m)$ is an isomorphism.*
- (2) *The fundamental group $\pi_1(\mathcal{M}_{1,1}^m(U(2))) \cong \mathbb{Z}^2 \rtimes \Gamma_{1,1}^m$.*

Proof.

- (1) By identifying $SU(2)$ with S^3 and $SO(3)$ with the real projective space $\mathbb{R}P^3$ we see that $SU(2)$ is a double covering of $SO(3)$. Hence, there is the short exact sequence

$$0 \longrightarrow \pi_1(\mathcal{R}_{SU(2)}(T)) \longrightarrow \pi_1(I_0) \longrightarrow (\mathbb{Z}/2)^2 \longrightarrow 0$$

by Lemmas 1.1.25 and 1.3.1. For $\pi_1(I_0) \cong (\mathbb{Z}/2)^2$ (by Theorem 1.3.4) it follows that $\pi_1(\mathcal{R}_{SU(2)}(T)) \cong 0$. Then Lemma 1.2.8 and Remark 1.2.9 imply that $\Phi(SU(2))_*$ is an isomorphism.

- (2) The map $SU(2) \times \mathbb{R} \rightarrow U(2)$ defined by $(A, \lambda) \mapsto \exp(\sqrt{-1}\lambda\pi)A$ for $A \in SU(2)$ and $\lambda \in \mathbb{R}$ is a covering with fiber \mathbb{Z} . Thus, we can deduce from (1) and Corollary 1.3.2 the short exact sequence

$$0 \longrightarrow \pi_1(\mathcal{R}_{SU(2) \times \mathbb{R}}(T)) \longrightarrow \pi_1(\mathcal{R}_{U(2)}(T)) \longrightarrow \pi_0(\mathcal{R}_{\mathbb{Z}}(T)) \longrightarrow 0.$$

It follows that $\pi_1(\mathcal{R}_{U(2)}(T)) \cong \mathbb{Z}^2$ so that $\pi_1(\mathcal{M}_{1,1}^m(U(2)))$ is isomorphic to $\mathbb{Z}^2 \rtimes \Gamma_{1,1}^m$ as a consequence of Remark 1.2.9 and Theorem 1.3.5.

□

Proposition 1.3.7. *If $G = PSL(2, \mathbb{R})$ or $G = SL(2, \mathbb{R})$ the moduli spaces $\mathcal{M}_{1,1}^m(G)$ are connected for all $m \geq 0$.*

Proof. In analogy to the Proof of Theorem 1.3.4 we consider $SL(2, \mathbb{R})$ as a group of linear transformations of \mathbb{R}^2 . Moreover, $SL(2, \mathbb{R})$ acts isometrically on the upper half plane \mathbb{H} . This action factors through $PSL(2, \mathbb{R})$. Every element $\begin{pmatrix} a & b \\ c & d \end{pmatrix} \in PSL(2, \mathbb{R})$ can be uniquely identified with a Möbius transformation $\mu : \mathbb{C} \rightarrow \mathbb{C}$, that is, $\mu(z) = \frac{az+b}{cz+d}$. To each element $A \in SL(2, \mathbb{R})$ with

$A = \begin{pmatrix} a & b \\ c & d \end{pmatrix}$ we may associate the Möbius transformation $\mu_A = \frac{az+b}{cz+d}$. Note that this correspondence is not one-to-one because the matrices $A = \begin{pmatrix} a & b \\ c & d \end{pmatrix}$ and $B = \begin{pmatrix} -a & -b \\ -c & -d \end{pmatrix}$ define the same Möbius transformation. On the other hand, this is the only ambiguity.

Every element $A \in SL(2, \mathbb{R})$ is contained in one of the following subsets. These will be referred to as

elliptic if A is conjugate to a matrix $\begin{pmatrix} \cos(\theta) & -\sin(\theta) \\ \sin(\theta) & \cos(\theta) \end{pmatrix}$ for some $\theta \in [0, 2\pi[$.

hyperbolic if A is conjugate to a matrix $\begin{pmatrix} \lambda & 0 \\ 0 & \lambda^{-1} \end{pmatrix}$ for $\lambda \neq 0$.

parabolic if A is conjugate to a matrix $\begin{pmatrix} 1 & x \\ 0 & 1 \end{pmatrix}$ for $x \in \mathbb{R}$.

Note that the identity element is the only one which is contained in all three subsets.

In order to determine the commuting pairs of $SL(2, \mathbb{R})$ we consider the appropriate Möbius transformations. More precisely, we say that $z_0 \in \mathbb{H} \cup \mathbb{R} \cup \{\infty\}$ is a *fixpoint* of a Möbius transformation $\mu(z) = \frac{az+b}{cz+d}$ if $\frac{az_0+b}{cz_0+d} = z_0$. By Chapter 2 of [34] two elements $A, B \in SL(2, \mathbb{R})$ commute if and only if μ_A and μ_B have the same fixpoint set. Moreover, it is shown in the indicated reference that by solving the equation $\frac{az+b}{cz+d} = z$ for a nonidentity element $A \in SL(2, \mathbb{R})$ the following is satisfied. If A is

elliptic then μ_A has exactly one fixpoint in \mathbb{H} .

hyperbolic then μ_A has exactly two fixpoints in $\mathbb{R} \cup \{\infty\}$.

parabolic then μ_A has exactly one fixpoint in $\mathbb{R} \cup \{\infty\}$.

It follows that two nonidentity elements $A, B \in SL(2, \mathbb{R})$ commute only if they are both elliptic, both parabolic or both hyperbolic. In this case, there

is a unique matrix C which transforms A and B simultaneously in the form indicated above. The Möbius transformation μ_C has the following form.

If A and B are *elliptic*, and μ_A and μ_B fix $x_0 \in \mathbb{H}$ then $\mu_C : i \mapsto x_0$.

If A and B are *hyperbolic*, and μ_A and μ_B fix $x_0, y_0 \in \mathbb{R} \cup \{\infty\}$ then $\mu_C : 0 \mapsto x_0$ and $\mu_C : \infty \mapsto y_0$.

If A and B are *parabolic*, and μ_A and μ_B fix $x_0 \in \mathbb{R} \cup \{\infty\}$ then $\mu_C : \infty \mapsto x_0$.

Now we will verify that from each commuting pair of $SL(2, \mathbb{R})$ there exists a path to the pair of identity elements $(e, e) \in SL(2, \mathbb{R})^2$ whose image lies in the same class.

So let $A, B \in SL(2, \mathbb{R})$ be elliptic such that $AB = BA$. Assume that μ_A and μ_B fix a point $x_0 \in \mathbb{H}$. There exists a matrix C as described above such that $A = C^{-1}A'C$ and $B = C^{-1}B'C$ where

$$A' = \begin{pmatrix} \cos(\alpha) & -\sin(\alpha) \\ \sin(\alpha) & \cos(\alpha) \end{pmatrix} \quad \text{and} \quad B' = \begin{pmatrix} \cos(\beta) & -\sin(\beta) \\ \sin(\beta) & \cos(\beta) \end{pmatrix}$$

for suitable angles $\alpha, \beta \in [0, 2\pi[$. Moreover, there are paths $\alpha_t = \alpha(1 - t)$ and $\beta_t = \beta(1 - t)$ in $[0, 2\pi[$, that is, $\alpha_0 = \alpha$ and $\beta_0 = \beta$ with end points $\alpha_1 = 0 = \beta_1$. We denote by A'_t and B'_t the rotation matrices about α_t and β_t , respectively. Let $A_t = C^{-1}A'_tC$ and $B_t = C^{-1}B'_tC$. Then the paths A_t and B_t consist of elliptic elements, commute pointwise and end in the identity element $e \in SL(2, \mathbb{R})$. Since \mathbb{H} is path connected, for all $x \in \mathbb{H}$ exists a continuous path $\omega : I \rightarrow \mathbb{H}$ with $\omega(0) = x_0$ and $\omega(1) = x$. There is a path $C_s \subseteq SL(2, \mathbb{R})$ such that $\mu_{C_s} : i \mapsto \omega(s)$. Then the double paths $A_{s,t} = C_s^{-1}A'_tC_s$ and $B_{s,t} = C_s^{-1}B'_tC_s$ consist of elliptic elements for all

$s, t \in I$, commute pointwise and end in the identity element $e \in SL(2, \mathbb{R})$. So the subset of commuting elliptic pairs is connected and contains the pair of identity elements (e, e) . Now we will check the same for parabolic and hyperbolic elements applying the analogous strategy.

Let $A, B \in SL(2, \mathbb{R})$ be hyperbolic elements such that $AB = BA$. Assume that μ_A and μ_B have fixpoints $x_0, y_0 \in \mathbb{R} \cup \{\infty\}$. There exists a matrix $C \in SL(2, \mathbb{R})$ as described such that $A = C^{-1}A'C$ and $B = C^{-1}B'C$ where

$$A' = \begin{pmatrix} \nu & 0 \\ 0 & \nu^{-1} \end{pmatrix} \quad \text{and} \quad B' = \begin{pmatrix} \lambda & 0 \\ 0 & \lambda^{-1} \end{pmatrix}$$

for suitable elements $\lambda, \nu \neq 0$. Since $\mathbb{R} \cup \{\infty\}$ is homeomorphic to S^1 it is path connected. Hence, for each pair of points $(x, y) \in (\mathbb{R} \cup \{\infty\})^2$ there exists a continuous path $\omega : I \rightarrow (\mathbb{R} \cup \{\infty\})^2$ with $\omega(0) = (x_0, y_0)$ and $\omega(1) = (x, y)$. Furthermore, there is a path $C_s \subseteq SL(2, \mathbb{R})$ such that $C_0 = C$ and μ_{C_s} maps 0 to the first coordinate of $\omega(s)$ and maps ∞ to the second coordinate of $\omega(s)$. Let ν_t and λ_t be paths in $\mathbb{R} - \{0\}$ which end in $1 \in \mathbb{R}$ and let A'_t and B'_t be matrices analogous to A' and B' defined by ν_t and λ_t , respectively. Then the paths $A_{s,t} = C_s^{-1}A'_tC_s$ and $B_{s,t} = C_s^{-1}B'_tC_s$ consist of hyperbolic elements for all $s, t \in I$, commute pointwise and end in the identity element $e \in SL(2, \mathbb{R})$. So the subset of commuting hyperbolic pairs is connected and contains the pair of identity elements (e, e) .

Let $A, B \in SL(2, \mathbb{R})$ be parabolic elements such that $AB = BA$. Assume that μ_A and μ_B fix a point $x_0 \in \mathbb{R} \cup \{\infty\}$. There is a matrix $C \in SL(2, \mathbb{R})$ as described above such that $A = C^{-1}A'C$ and $B = C^{-1}B'C$ where

$$A' = \begin{pmatrix} 1 & \alpha \\ 0 & 1 \end{pmatrix} \quad \text{and} \quad B' = \begin{pmatrix} 1 & \beta \\ 0 & 1 \end{pmatrix}$$

for suitable elements $\alpha, \beta \in \mathbb{R}$. The argumentation works as before. For each $x \in \mathbb{R} \cup \{\infty\}$ exists a continuous path $\omega : I \rightarrow \mathbb{R} \cup \{\infty\}$ with $\omega(0) = x_0$ and $\omega(1) = x$ that induces a path $C_s \subseteq SL(2, \mathbb{R})$ with $\mu_{C_s} : \infty \mapsto \omega(s)$. On the other hand, let α_t and β_t be paths in \mathbb{R} with $\alpha_0 = \alpha$ and $\beta_0 = \beta$ and whose end point is $0 \in \mathbb{R}$. We define $A_{s,t}$ and $B_{s,t}$ as before. Then these are two paths in $SL(2, \mathbb{R})$ consisting of parabolic elements for all $s, t \in I$, commuting pointwise and ending in the identity element $e \in SL(2, \mathbb{R})$. Hence, the subset of commuting parabolic pairs is connected and contains the pair of identity elements (e, e) .

Consequently, $\mathcal{R}_{SL(2, \mathbb{R})}(T)$ and hence $\mathcal{R}_{PSL(2, \mathbb{R})}(T)$ (see Lemma 1.1.25) are connected. Since $\mathcal{M}_{1,1}(G) \rightarrow \mathcal{M}_{1,1}$ is a fiber bundle with fiber $\mathcal{R}_G(T)$ for $G = SL(2, \mathbb{R})$ and $G = PSL(2, \mathbb{R})$ by Lemma 1.2.8 we can deduce the assertion from the long exact sequence of homotopy groups.

□

After the computation of homotopy groups we next turn to homology groups of some moduli spaces of flat G -bundles.

Example 1.3.8.

$$H^p(\mathcal{M}_{1,1}(SU(2))) \cong \begin{cases} \mathbb{Z}, & \text{if } p = 0, 1 \\ \mathbb{Z}/2, & \text{if } p = 4, 5 \\ 0, & \text{else.} \end{cases}$$

Proof. The integral cohomology of $\mathcal{M}_{1,1}$ was calculated in [1]: $H^p(\mathcal{M}_{1,1}) \cong \mathbb{Z}$ for $p = 0, 1$ and it is trivial in all other degrees. The integral cohomology of

$\mathcal{R}_{SU(2)}(T)$ was determined in Theorem 1.4 of [3]:

$$H^q(\mathcal{R}_{SU(2)}(T)) \cong \begin{cases} \mathbb{Z}, & \text{if } q = 0, 2, \\ 0, & \text{if } q = 1 \text{ or } q \geq 5, \\ \mathbb{Z}^2, & \text{if } q = 3, \\ \mathbb{Z}/2, & \text{if } q = 4. \end{cases}$$

By Lemma 1.2.8 we can apply the Leray–Serre spectral sequence to the fiber bundle $\mathcal{M}_{1,1}(SU(2)) \rightarrow \mathcal{M}_{1,1}$ with fiber $\mathcal{R}_{SU(2)}(T)$. Its E_2 -term is given by $H^p(\mathcal{M}_{1,1}; H^q(\mathcal{R}_{SU(2)}(T)))$. As the moduli space $\mathcal{M}_{1,1}$ is homotopy equivalent to $B\Gamma_{1,1}$ we will calculate the group cohomology of $\Gamma_{1,1}$ with local coefficients $H^q(\mathcal{R}_{SU(2)}(T))$. For this, we first consider the cohomology of $SL(2, \mathbb{Z})$ with local coefficients since $\mathbb{Z} \rightarrow \Gamma_{1,1} \rightarrow SL(2, \mathbb{Z})$ is an extension. For the computation of the E_2 -term $E_2^{p,q} = H^p(SL(2, \mathbb{Z}); H^q(\mathcal{R}_{SU(2)}(T)))$ we apply the Hochschild–Serre spectral sequence to $\mathbb{Z}/2 \rightarrow SL(2, \mathbb{Z}) \rightarrow PSL(2, \mathbb{Z})$. For all oncoming calculations note that the action of the mapping class group on the cohomology of the representation variety is nontrivial and factors through the symplectic group $Sp(2, \mathbb{Z})$ (see Section 3 of [55]). As a consequence, $SL(2, \mathbb{Z})$ acts nontrivially on the local coefficients $H^q(\mathcal{R}_{SU(2)}(T))$. The group $SL(2, \mathbb{Z})$ admits $\mathbb{Z}/2$ as a normal subgroup where $\mathbb{Z}/2$ is considered as the multiplicative group $\{1, -1\}$. Thus, $\mathbb{Z}/2$ acts as a scalar group diagonally on \mathbb{Z}^2 by multiplication. More precisely, let $\epsilon \in \mathbb{Z}/2$ and $(z_1, z_2) \in \mathbb{Z}^2$, then the action is defined by $(\epsilon, (z_1, z_2)) \mapsto (\epsilon z_1, \epsilon z_2)$. This $\mathbb{Z}/2$ -action induces the structure of a direct sum of two nontrivial $\mathbb{Z}/2$ -modules of rank 1 on \mathbb{Z}^2 .

Moreover, $SL(2, \mathbb{Z})$ acts nontrivially on \mathbb{Z} by a unique homomorphism. To this end, note that any homomorphism $SL(2, \mathbb{Z}) \rightarrow \mathbb{Z}/2$ has to factor through

the abelianization of $SL(2, \mathbb{Z})$. The abelianization is isomorphic to $\mathbb{Z}/12$. But there exists only one nontrivial homomorphism $\mathbb{Z}/12 \rightarrow \mathbb{Z}/2$. Consequently, the nontrivial group action $SL(2, \mathbb{Z}) \rightarrow \text{Aut}(\mathbb{Z}) \cong \mathbb{Z}/2$ is uniquely defined. Having described the group actions on the local coefficients it follows that $H^0(\mathbb{Z}/2; \mathbb{Z}^2) = 0$, $H^0(\mathbb{Z}/2; \mathbb{Z}) = 0$, $H^1(\mathbb{Z}/2; \mathbb{Z}^2) = (\mathbb{Z}/2)^2$ and $H^1(\mathbb{Z}/2; \mathbb{Z}) = \mathbb{Z}/2$. The quotient group $SL(2, \mathbb{Z})/\mathbb{Z}/2$ is isomorphic to $PSL(2, \mathbb{Z})$. By means of the homomorphism $SL(2, \mathbb{Z})/\mathbb{Z}/2 \rightarrow SL(2, \mathbb{Z}/2)$, it acts on $(\mathbb{Z}/2)^2$ and $\mathbb{Z}/2$. Consequently, $H^0(PSL(2, \mathbb{Z}); H^1(\mathbb{Z}/2; \mathbb{Z}^2))$ and $H^0(PSL(2, \mathbb{Z}); H^1(\mathbb{Z}/2; \mathbb{Z}))$ are trivial. Then from the Hochschild–Serre spectral sequence we have that $H^p(SL(2, \mathbb{Z}); H^q(\mathcal{R}_{SU(2)}(T))) = 0$ for $q = 2, 3$ and $p \geq 0$. In particular, it follows that $E_2^{p,q} = 0$ for $q = 2, 3$ and $p \geq 0$. Moreover, $E_2^{p,1} = 0$ for $H^1(\mathcal{R}_{SU(2)}(T)) = 0$. Further, it was shown in Lemma 1.3.1 that $\mathcal{R}_{SU(2)}(T)$ is connected. Thus, $E_2^{p,0}$ is just the ordinary cohomology $H^p(SL(2, \mathbb{Z}); \mathbb{Z})$ for all $p \geq 0$. Finally, the action of $\mathbb{Z}/2$ on itself is trivial. Hence, $E_2^{p,4}$ is also just the ordinary cohomology $H^p(SL(2, \mathbb{Z}); \mathbb{Z}/2)$ for all $p \geq 0$.

Summarizing these consideration, the E_2 -term $E_2^{p,q}$ is shown in Figure 1.3. We see from the diagram in Figure 1.3 that this spectral sequence collapses in the E_2 -term. To finish the proof we apply the Hochschild–Serre spectral sequence to the extension $\mathbb{Z} \rightarrow \Gamma_{1,1} \rightarrow SL(2, \mathbb{Z})$. By executing the analogous computations as above (we have already computed the cohomology of $SL(2, \mathbb{Z})$ with local coefficients) the assertion follows.

□

As we do not introduce spectral sequence techniques here we refer to Chapter 5 for the Leray–Serre spectral sequence and to Section 12.1 for the Hochschild–Serre spectral sequence of [43].

4	$\mathbb{Z}/2$	$\mathbb{Z}/2$
3	0	0
2	0	0
1	0	0
0	\mathbb{Z}	\mathbb{Z}
	0	1

Figure 1.3: E_2 -term for $H^p(\mathcal{M}_{1,1}(SU(2)))$

1.4 Moduli spaces of flat G -bundles for abelian groups

As we have mentioned before, moduli spaces $\mathcal{M}_{g,1}^m(G)$ enjoy special properties if G is abelian. In particular, if G is connected, then $\mathcal{M}_{g,1}^m(G)$ is a classifying space.

Proposition 1.4.1. *The moduli space $\mathcal{M}_{g,1}^m(U(1))$ is a classifying space whose fundamental group is isomorphic to $\mathbb{Z}^{2g} \rtimes \Gamma_{g,1}^m$.*

Proof. The representation variety $\mathcal{R}_{U(1)}(S_{g,1}^m)$ is isomorphic to $U(1)^{2g}$, that is, a torus. Thus, it is a classifying space since $U(1)^{2g}$ a model for $B\mathbb{Z}^{2g}$. By Lemma 1.2.8, $\mathcal{M}_{g,1}^m(U(1))$ is homotopy equivalent to $E\Gamma_{g,1}^m \times_{\Gamma_{g,1}^m} B\mathbb{Z}^{2g}$. In general, for two groups H and K with a group action $H \rightarrow \text{Aut}(K)$ we have that $B(K \rtimes H)$ is homotopy equivalent to $EH \times_H BK$. This follows from the fact that these two bundles which are given by the two projections $B(K \rtimes H) \rightarrow BH$ and $EH \times_H BK \rightarrow BH$ are isomorphic in view of the

universality of the classifying space. Consequently, $\mathcal{M}_{g,1}^m(U(1))$ is homotopy equivalent to $B(\mathbb{Z}^{2g} \rtimes \Gamma_{g,1}^m)$. As $\mathbb{Z}^{2g} \rtimes \Gamma_{g,1}^m$ is discrete, the moduli space is an Eilenberg–Mac Lane space of type $(\mathbb{Z}^{2g} \rtimes \Gamma_{g,1}^m, 1)$.

□

Corollary 1.4.2. *Let G be a connected abelian Lie group. Then $\mathcal{M}_{g,1}^m(G)$ is a classifying space with fundamental group $\mathbb{Z}^{2gp} \rtimes \Gamma_{g,1}^m$ where p is the dimension of the maximal torus of G .*

Proof. Every connected abelian Lie group is the product of an Euclidean space and a torus, that is, $U(1)^p \times \mathbb{R}^q$. Thus, $\mathcal{R}_G(S_{g,1}^m)$ is homotopy equivalent to $U(1)^{2gp}$, that is, $B\mathbb{Z}^{2gp}$. The assertion follows as in Proposition 1.4.1.

□

Remark 1.4.3. Let X be a Riemann surface. We have seen in Example 1.1.24 that $\mathcal{R}_{U(1)}(X)$ can be identified with the Jacobi variety of X . In particular, it is a complex manifold. It was shown in Theorem 1.1 of [27] that the mapping class group preserves any volume form on $\mathcal{R}_{U(1)}(X)$. Consequently, the mapping class group acts orientation preserving on this representation variety.

Example 1.4.4.

$$H^p(\mathcal{M}_{1,1}(U(1))) \cong \begin{cases} \mathbb{Z}, & \text{if } p \leq 3 \\ 0, & \text{else} \end{cases}$$

Proof. We proceed similarly as in Example 1.3.8. The integral cohomology of $\mathcal{M}_{1,1}$ was calculated in [1] and $\mathcal{R}_{U(1)}(S_{1,1})$ is the torus $T = U(1)^2$. Because of Lemma 1.2.8 we can apply the Leray–Serre spectral sequence to the fiber bundle $\mathcal{R}_{U(1)}(S_{1,1}) \rightarrow \mathcal{M}_{1,1}(U(1)) \rightarrow \mathcal{M}_{1,1}$ with structure group $\Gamma_{1,1}$. Its

E_2 -term is given by $H^p(\mathcal{M}_{1,1}; H^q(\mathcal{R}_{U(1)}(S_{1,1})))$. So it follows immediately from the calculations in [1] that $E_2^{p,q} = 0$ for $p \geq 2$ and $q \geq 3$. Since T is connected $E_2^{p,0}$ is isomorphic to the cohomology $H^p(\mathcal{M}_{1,1}; \mathbb{Z})$ with constant coefficients. Further, we have noticed in Remark 1.4.3 that the mapping class group acts orientation preserving on $\mathcal{R}_{U(1)}(X)$ for every $[X, \mathcal{P}, \mathcal{Q}] \in \mathcal{M}_{1,1}$. Consequently, $E_2^{p,2}$ is also isomorphic to $H^p(\mathcal{M}_{1,1}; \mathbb{Z})$ with constant coefficients. It follows that $E_2^{p,q} \cong \mathbb{Z}$ for $p = 0, 1$ and $q = 0, 2$. It remains to determine the groups $E_2^{0,1}$ and $E_2^{1,1}$. The moduli space $\mathcal{M}_{1,1}$ is homotopy equivalent to $B\Gamma_{1,1}$. Hence we will calculate the group cohomology of $\Gamma_{1,1}$ with local coefficients $H^1(\mathcal{R}_{U(1)}(S_{1,1}))$. To this end, we first consider the group cohomology of $SL(2, \mathbb{Z})$ since $\mathbb{Z} \rightarrow \Gamma_{1,1} \rightarrow SL(2, \mathbb{Z})$ is an extension. For its computation we apply the Hochschild–Serre spectral sequence to $\mathbb{Z}/2 \rightarrow SL(2, \mathbb{Z}) \rightarrow PSL(2, \mathbb{Z})$ as in Example 1.3.8. Recall that $H^i(PSL(2, \mathbb{Z}); H^j(\mathbb{Z}/2; \mathbb{Z}^2)) = 0$ for $j = 0, 1$. It follows for the E_2 -term of our Leray–Serre spectral sequence that $E_2^{p,1} = 0$ for $p = 0, 1$. For all further details of the computation see Example 1.3.8. Now the E_2 -term has the form as shown in Figure 1.4.

2	\mathbb{Z}	\mathbb{Z}
1	0	0
0	\mathbb{Z}	\mathbb{Z}
	0	1

Figure 1.4: E_2 -term for $H^p(\mathcal{M}_{1,1}(U(1)))$

As a consequence, the spectral sequence collapses in the E_2 -term and the

result follows as desired.

□

Remark 1.4.5. By means of the calculations in the proof of 1.4.4, we are in a position to determine the generators of each cohomology group $H^p(\mathcal{M}_{1,1}(U(1)))$. As $\mathcal{M}_{1,1}$ (see [1]) and the torus T are orientable and the mapping class group acts orientation preserving on the representation variety (see Remark 1.4.3) the orientability of $\mathcal{M}_{1,1}(U(1))$ follows. All cohomology groups are torsion free. As a consequence of the universal coefficient theorem we may consider homology groups by duality. Let x_0 and x_1 be generators of $H_0(\mathcal{M}_{1,1})$ and $H_1(\mathcal{M}_{1,1})$, respectively. The class x_1 is the fundamental class. It was shown in [1] that it is represented by a Dehn twist along a simple closed curve. Let y_i be a generator of $H_i(T)$ for $i = 0, 2$ and y_1, y'_1 two generators of $H_1(T)$. We identify $\mathcal{R}_{U(1)}(S_{1,1})$ with the torus $U(1)^2 = T$ as the following considerations do not depend on the choice of such an identification. Then y_2 is represented by the fundamental class of the torus, while y_1 and y'_1 are represented by a pair of simple closed curves in T intersecting transversally. It follows from the E_2 -term of the Leray–Serre spectral sequence (see Example 1.4.4) that $x_0 \otimes y_0$ generates $H_0(\mathcal{M}_{1,1}(U(1)))$ and is represented by the connected component of this moduli space. Note that we have seen in Example 1.3.3 as well as Proposition 1.4.1 that $\mathcal{M}_{1,1}(U(1))$ is connected. The class $x_1 \otimes y_2$ generates $H_3(\mathcal{M}_{1,1}(U(1)))$ and determines the fundamental class of $\mathcal{M}_{1,1}(U(1))$. Furthermore, $x_0 \otimes y_2$ is a generator of $H_2(\mathcal{M}_{1,1}(U(1)))$ represented by the fiberwise orientation of the fibers in terms of Lemma 1.2.8. In the same vein, $x_1 \otimes y_0$ generates $H_1(\mathcal{M}_{1,1}(U(1)))$. Geometrically, this class can be interpreted as follows. The bundle projection $\Phi(U(1))$ admits a section by Remark 1.2.9 which is defined by means of the trivial representation ρ_0 . The mapping class group fixes ρ_0 when acting

on $\mathcal{R}_{U(1)}(S_{1,1})$. As a consequence, a Dehn twist representing x_1 can be lifted to the total space $\mathcal{M}_{1,1}(U(1))$ at the point ρ_0 . Such a Dehn twist represents $x_1 \otimes y_0$.

1.5 Moduli spaces of coverings

In this section we consider a very special class of moduli spaces of fiber bundles, namely where the fiber and structure group are discrete or even finite. These coverings are flat bundles since their structure group is discrete. As we will see in the sequel these can often be treated by means of combinatorial methods in contrast to general principal G -bundles.

Proposition 1.5.1. *Let $H \leq G$ be a subgroup of a discrete group G . Then $\mathcal{M}_{g,1}^m(H)$ consists of components of $\mathcal{M}_{g,1}^m(G)$.*

Proof. As G and H are discrete $\mathcal{R}_G(S_{g,1}^m)$ and $\mathcal{R}_H(S_{g,1}^m)$ are discrete spaces. The inclusion $\mathcal{R}_H(S_{g,1}^m) \rightarrow \mathcal{R}_G(S_{g,1}^m)$ is $\Gamma_{g,1}^m$ -equivariant. Consequently, $\mathcal{M}_{g,1}^m(H) \rightarrow \mathcal{M}_{g,1}^m(G)$ is a continuous inclusion. By Lemma 1.2.8, $\Phi(H)$ and $\Phi(G)$ are covering projections onto the moduli space $\mathcal{M}_{g,1}^m$.

Let $C \subseteq \mathcal{M}_{g,1}^m(H)$ be a connected component. Then there is a connected component C' of $\mathcal{M}_{g,1}^m(G)$ such that $C \subseteq C'$. It remains to show that $C = C'$. To this end, let $x_0, x_1 \in \mathcal{M}_{g,1}^m$ and let $\omega : I \rightarrow \mathcal{M}_{g,1}^m$ be a continuous path with $\omega(0) = x_0$ and $\omega(1) = x_1$. Consider $y_i \in \Phi(G)^{-1}(x_i) \cap C$ for $i = 0, 1$. As $\Phi(G)$ is a covering projection there exists a lift $\tilde{\omega} : I \rightarrow \mathcal{M}_{g,1}^m(G)$ of ω with $\tilde{\omega}(0) = y_0$ and $\tilde{\omega}(1) = y_1$. The image of $\tilde{\omega}$ is contained in C' . Moreover, $\tilde{\omega}$ defines a deck transformation $f : \mathcal{M}_{g,1}^m(G) \rightarrow \mathcal{M}_{g,1}^m(G)$ such that $f(y_0) = y_1$. But $f' = f|_{\mathcal{M}_{g,1}^m(H)}$ is a deck transformation of $\Phi(H)$ with $f'(y_0) = y_1$. Then each path which is homotopic to $\tilde{\omega}$ is contained in $C' \cap \mathcal{M}_{g,1}^m(H)$. Thus, there is a path component $C'' \subseteq \mathcal{M}_{g,1}^m(H)$ with $C' \subseteq C''$. Consequently,

$C \subseteq C' \subseteq C''$ and so $C = C''$. It follows that $C = C'$.

□

Notation. The moduli space $\mathcal{M}_{g,1}^m[K]^G$ is defined in the sense of 1.2.6 for $K \geq 1$: it consists of equivalence classes of K -sheeted, unramified, pointed coverings of Riemann surfaces with structure group G . We denote by $\mathcal{M}_{g,1}^m[K]_0^G$ the moduli space of connected, K -sheeted, unramified, pointed coverings with structure group G . Then $\mathcal{M}_{g,1}^m[K]_0^G \subseteq \mathcal{M}_{g,1}^m[K]^G$. Moreover, we set $\mathcal{M}_{g,1}^m[K]_*^G$ for the moduli space of K -sheeted, pointed coverings with structure group G with a finite number (unequal zero) of branch points. We drop the superscript G , that is, we write $\mathcal{M}_{g,1}^m[K]$, $\mathcal{M}_{g,1}^m[K]_0$ and $\mathcal{M}_{g,1}^m[K]_*$ in case G equals the full symmetric group \mathfrak{S}_K .

Lemma 1.5.2. *Let $G \leq \mathfrak{S}_K$ be a subgroup of the symmetric group. Then the following canonical projections are coverings of the moduli space $\mathcal{M}_{g,1}^m$.*

$$(1) \Phi(K)^G : \mathcal{M}_{g,1}^m[K]^G \rightarrow \mathcal{M}_{g,1}^m$$

$$(2) \Phi(K)_0^G : \mathcal{M}_{g,1}^m[K]_0^G \rightarrow \mathcal{M}_{g,1}^m$$

$$(3) \Phi(K)_*^G : \mathcal{M}_{g,1}^m[K]_*^G \rightarrow \mathcal{M}_{g,1}^m$$

Proof. A covering is a flat bundle since its holonomy group is discrete. Moreover, coverings of Riemann surfaces can be characterized by representations of the fundamental group in its structure group. The structure group $G \leq \mathfrak{S}_K$ acts on K points of the fiber. The number of equivalence classes of pointed coverings with structure group G then corresponds to the number of homomorphisms in $\text{Hom}(\pi_1, G)$. Because of Proposition 1.5.1 it is sufficient to prove the assertions for $G = \mathfrak{S}_K$.

The fundamental group π_1 is finitely generated and \mathfrak{S}_K is a finite group

for all $K \geq 1$. A representation is uniquely determined by its values on a fixed generating set of π_1 . Thus, there are only finitely many representations $\rho : \pi_1 \rightarrow \mathfrak{S}_K$. It follows that the number of equivalence classes of unramified, K -sheeted, pointed coverings of a Riemann surface is finite. Moreover, this number depends only on the topological type of the surface. The number of equivalence classes of connected, unramified, K -sheeted, pointed coverings of a Riemann surface is given by those representations ρ for which $\ker(\rho) \leq \pi_1$ is a subgroup of index K . Analogous to Lemma 1.2.8 $\mathcal{M}_{g,1}^m[K]^G$ is a fiber bundle over $\mathcal{M}_{g,1}^m$ with structure group $\Gamma_{g,1}^m$. More precisely, $\mathcal{M}_{g,1}^m[K]^G$ is in one-to-one correspondence with $\mathcal{T}_{g,1}^m \times_{\Gamma_{g,1}^m} \mathcal{R}_G(S_{g,1}^m)$. The topology of $\mathcal{M}_{g,1}^m[K]^G$ is defined by means of this identification. As the structure group is discrete and the fiber is finite (1) and (2) hold.

The number of equivalence classes of ramified coverings corresponds to the number of tuples $(\alpha_1, \dots, \alpha_g, \beta_1, \dots, \beta_g, \delta_1, \dots, \delta_r)$ in \mathfrak{S}_K^{2g+r} such that $\prod_{1 \leq i \leq g} [\alpha_i, \beta_i] \prod_{1 \leq j \leq r} \delta_j = 1$. Here r denotes the number of branch points on the surface. This characterization of ramified coverings arises from the theory of monodromy representations that we have considered in Section 1.1. The monodromy is not trivial at the branch points. In addition, the number of tuples $(\delta_1, \dots, \delta_r)$ parameterizing the monodromy at the branch points is finite. So it follows analogously to the unramified case that $\mathcal{M}_{g,1}^m[K]^G_* \rightarrow \mathcal{M}_{g,1}^m$ is a covering projection.

□

For the exact number of sheets for $\Phi(K)$, $\Phi(K)_0$ and $\Phi(K)_*$ we refer to the survey [37].

Remark 1.5.3. Let G be a finite group whose order we denote by $|G|$. Let us choose a labeling of the elements of G such that $G = \{g_j\}_{1 \leq j \leq |G|}$. We consider the action of G on itself by left multiplication. This induces a

permutation of the index set $\{1, \dots, |G|\}$. Thus, G acts as a permutation group on itself and can be considered as a subgroup of the symmetric group $\mathfrak{S}_{|G|}$. We obtain a homeomorphism $\mathcal{M}_{g,1}^m(G) \rightarrow \mathcal{M}_{g,1}^m[|G|]^G$. In particular, $\mathcal{M}_{g,1}^m(G)$ consists of components of $\mathcal{M}_{g,1}^m[|G|]$ by Proposition 1.5.1.

Definition 1.5.4. The *Hurwitz space* $\mathcal{H}_r(X)[K]$ of X is the moduli space of K -sheeted, ramified, pointed coverings of a Riemann surface X with $r \geq 1$ branch points $p_1, \dots, p_r \in X$. We set $\mathcal{H}_r[K] = \mathcal{H}_r(\mathbb{CP}^1)[K]$ for the Riemann sphere \mathbb{CP}^1 .

Note that since the fundamental group of \mathbb{CP}^1 is trivial there are no nontrivial unramified coverings of the Riemann sphere. It is therefore reasonable to assume $r \geq 1$ in Definition 1.5.4.

In order to state the main theorem of this section we first introduce the following notations.

Notation.

- (1) Let M be a topological space. We denote by $b_0(M)$ the number of connected components of M .
- (2) We write $\Pi(K)$ for the number of partitions of the natural number $K \in \mathbb{N}$. For further details on the partition function Π see for instance Chapter 1.2 of [4].
- (3) We set C_k for the cyclic group of order $k \in \mathbb{N}$.
- (4) Let G and H be two finite groups. Then we denote by $H \wr G$ the wreath product $H^{|G|} \rtimes G$ where G acts on itself as a permutation group from the left (compare with Remark 1.5.3).

Theorem 1.5.5. *The number of connected components $b_0(\mathcal{M}_{g,1}[K])$ is a function of $b_0(\mathcal{M}_{1,1}[K])$, $b_0(\mathcal{H}_3[K])$ and the genus g .*

- (1) The number $b_0(\mathcal{M}_{1,1}[K])$ is a function of $\Pi(K)$ and the number of all transitive subgroups $H \leq \mathfrak{S}_K$ satisfying the following property. There are $s, t \in \mathbb{N}$ so that H is a subgroup of the wreath product $\mathbb{Z}/s\mathbb{Z} \wr C_t$.
- (2) The number $b_0(\mathcal{H}_r[K])$ equals the number of orbits of the pure braid group PB_r on the set of monodromy representations for $r \geq 1$.

Corollary 1.5.6. *The moduli space $\mathcal{M}_{g,1}[K]_*$ has infinitely many connected components.*

Since the proof of Theorem 1.5.5 is very long and technical we will just sketch the main ideas. To this end, we have to explain how the moduli space of Riemann surfaces with boundary components is related to the moduli space of Riemann surfaces with dipole points. For this reason, we introduce the following notation and present a brief account on the relationship between surfaces with boundary components in contrast to surfaces with dipole points.

Notation. By $F_{g,n}$ we denote a compact, connected, oriented surface of genus $g \geq 0$ with $n \geq 0$ boundary components. We set as usual F_g for $F_{g,0}$. The surface $F_{g,n}$ is constructed from F_g by considering the complement of n open, pairwise disjoint disks.

The mapping class group $\Gamma(F_{g,n})$ of $F_{g,n}$ is given by all orientation preserving diffeomorphisms $Diff(F_{g,n})$ of $F_{g,n}$ which fix the boundary components pointwise up to isotopies fixing the boundary pointwise. The following lemma from Section 1.3 of [9] legitimizes the transfer between the Riemann surface model with boundary components and dipole points.

Lemma 1.5.7. *The mapping class group $\Gamma_{g,n}$ is isomorphic to $\Gamma(F_{g,n})$ and $Diff_{g,n}$ is homotopy equivalent to $Diff(F_{g,n})$.*

As a consequence of Lemma 1.5.7, the classifying spaces $B\Gamma_{g,n}$ and $B\Gamma(F_{g,n})$ are homotopy equivalent. Thus, we will utilize the notation $\Gamma_{g,n}$ and $Diff_{g,n}$ in both cases. Moreover, the connected components of $Diff_{g,n}$ are contractible for $g \geq 2$ (see [22]). So the classifying spaces of $\Gamma_{g,n} = \pi_0(Diff_{g,n})$ and $Diff_{g,n}$ are homotopy equivalent.

Next we sketch the proof of Theorem 1.5.5 and Corollary 1.5.6.

Proof. By means of the same arguments as in the proof of Lemma 1.5.2 it follows that $b_0(\mathcal{M}_{g,1}[K])$ equals the number of $\Gamma_{g,1}$ -orbits of the $\Gamma_{g,1}$ -action on $\mathcal{T}_{g,1} \times \mathcal{R}_{\mathfrak{S}_K}(S_{g,1})$. Thus, it remains to determine the number of $\Gamma_{g,1}$ -orbits of the $\Gamma_{g,1}$ -action on $\mathcal{R}_{\mathfrak{S}_K}(S_{g,1})$.

First we explain why $b_0(\mathcal{M}_{g,1}[K])$ is a function of $b_0(\mathcal{M}_{1,1}[K])$, $b_0(\mathcal{H}_3[K])$ and the genus g . Let $\pi : E \rightarrow X$ be a K -sheeted, unramified covering of a Riemann surface X of genus $g \geq 2$. We consider a subsurface decomposition of X as in Section 3.8 of [26]. Then X is decomposed into g subsurfaces homeomorphic to a torus with one boundary component and $g - 2$ subsurfaces homeomorphic to a pair-of-pants. As E is a Riemann surface itself there is an induced subsurface decomposition of E which is lifted from the subsurface decomposition of X . The decompositions are respected by the action of the mapping class group in the following sense. Let f be an orientation preserving diffeomorphism of X and let $X' = f(X)$. The subsurface decomposition of X defines a subsurface decomposition of X' . Moreover, there is an induced orientation preserving diffeomorphism F of E satisfying the following properties. Let $E' = F(E)$, then E' has a subsurface decomposition from E which agrees with the lifted subsurface decomposition of X' to E . In addition, we have $F \circ \pi = \pi \circ f$. Thus, we may consider the number of connected components of the moduli spaces of unramified coverings of the subsurfaces.

To (1): Let $\rho \in \mathcal{R}_{\mathfrak{S}_K}(S_{1,1})$ and let $O(\rho)$ be the orbit of the $\Gamma_{1,1}$ -action of ρ . If $\tau \in O(\rho)$ then $b_0(E_\tau) = b_0(E_\rho)$. Thus, $b_0(\mathcal{M}_{1,1}[K])$ is a function of $\Pi(K)$. As any connected component of a covering is a covering it remains to determine $b_0(\mathcal{M}_{1,1}[K]_0)$. To this end, we fix a generating set e_1, e_2 of $\pi_1(S_{1,1})$ as introduced in Section 1.1. To determine $O(\rho)$ for $\rho \in \mathcal{R}_{\mathfrak{S}_K}(S_{1,1})$ we identify ρ with its image on e_1 and e_2 . So let $\alpha_i = \rho(e_i)$ for $i = 1, 2$. Then (α_1, α_2) is a commuting pair of \mathfrak{S}_K and the monodromy group $\langle \alpha_1, \alpha_2 \rangle$ generated by α_1 and α_2 is transitive if and only if E_ρ is connected. We assume that E_ρ is connected. Note that $\langle \alpha_1, \alpha_2 \rangle$ is contained in the centralizers $C(\alpha_i)$ for $i = 1, 2$. But both centralizers are isomorphic to a wreath product $\mathbb{Z}/s\mathbb{Z} \wr C_t$ for some $s, t \in \mathbb{N}$ (see Section 14 of [39]). Let $\tau \in O(\rho)$ and $\beta_i = \tau(e_i)$ for $i = 1, 2$. Then $\langle \alpha_1, \alpha_2 \rangle$ is isomorphic to $\langle \beta_1, \beta_2 \rangle$. Since by Theorem 1.1.22 every transitive subgroup of the symmetric group is realized as the monodromy group of an unramified, K -sheeted covering the assumption follows as desired.

To (2): Ramified coverings of the sphere S^2 with $r \geq 1$ branch points are in one-to-one correspondence with unramified coverings of $F_{0,r}$, that is, the sphere S^2 with r boundary components. The ramification type of the ramified covering equals the monodromy type of the unramified covering. After fixing a generating set of $\pi_1(F_{0,r})$ we identify every representation of $\mathcal{R}_{\mathfrak{S}_K}(F_{0,r})$ with its image in \mathfrak{S}_K^r . Then the action of $\Gamma_{0,r}$ on $\mathcal{R}_{\mathfrak{S}_K}(F_{0,r})$ determines an action of the braid group B_r on the set of monodromy types. Since we have fixed a labeling of the branch points the number of orbits of the pure braid group equals $b_0(\mathcal{H}_r[K])$.

To Corollary 1.5.6: Two coverings with a different number of branch points

or ramification points are not contained in the same connected component of $\mathcal{M}_{g,1}[K]_*$. Let $\mathcal{M}_{g,1}[K, r]_*$ be the moduli space of ramified, K -sheeted coverings of Riemann surfaces of genus $g \geq 1$ with $r \geq 1$ branch points. By reducing the problem to the unramified case it follows that $b_0(\mathcal{M}_{g,1}[K, r]_*)$ is a function of $b_0(\mathcal{H}_3[K])$, $b_0(\mathcal{M}_{1,1}[K])$, $\Pi(K)$ and g as well as r by Theorem 1.5.5. But $b_0(\mathcal{M}_{g,1}[K]_*) = \sum_{r \geq 1} b_0(\mathcal{M}_{g,1}[K, r]_*)$ and so the assumption follows.

□

Of course, the previous statements are qualitative in character. The exact calculation of the number of connected components remains an interesting task. Nevertheless, we can say more in some special cases. To this end, note that a method is given on how to construct transitive subgroups of the symmetric group in [32]. The described algorithm (see Section 5 of this reference) can be changed to construct transitive subgroups we are looking for in (1) of Theorem 1.5.5. Using Table 1 of Section 12 in [32] we obtain the following results.

Corollary 1.5.8.

(1) *We have $b_0(\mathcal{M}_{1,1}[2]_0) = 1$ and $b_0(\mathcal{M}_{1,1}[2]) = 2$. By means of our considerations in the proof of Theorem 1.5.5 we are in a position to say more about the two connected components of $\mathcal{M}_{1,1}[2]$. One component is $\mathcal{M}_{1,1}[2]_0$ (see also Lemma 1.5.2). The other connected component contains equivalence classes of the trivial 2-sheeted coverings of Riemann surfaces of topological type $S_{1,1}$. Thus, this latter component is homeomorphic to $\mathcal{M}_{1,1}$. The moduli space $\mathcal{M}_{1,1}[2]_0$ will be considered in Example 2.3.9 in more detail.*

(2) *We have $b_0(\mathcal{M}_{1,1}[3]_0) = 1$ and $b_0(\mathcal{M}_{1,1}[3]) = 3$.*

(3) We have $b_0(\mathcal{M}_{1,1}[4]_0) = 4$ and the four components are characterized by the three conjugates of C_4 and the Klein four-group H . These are

$$C_4 \cong \{e, (1, 2, 3, 4), (1, 4, 2, 3), (1, 3)(2, 4)\},$$

$$C_4 \cong \{e, (1, 3, 2, 4), (1, 4, 2, 3), (1, 2)(3, 4)\},$$

$$C_4 \cong \{e, (1, 3, 4, 2), (1, 2, 4, 3), (1, 4)(2, 3)\},$$

$$H \cong \{e, (1, 2)(3, 4), (1, 3)(2, 4), (1, 4)(2, 3)\}.$$

Motivated by Theorem 1.5.5 we will calculate the action of the braid group on the set of monodromy representations explicitly. But before doing so let us review some facts on braid groups following [8] (applying a slightly different notation). For a connected topological space M , let $\tilde{\mathcal{C}}^r(M)$ denote the space $\{(x_1, \dots, x_r) \in M^r \mid \forall i \neq j : x_i \neq x_j\}$. It is called the *r*-th *ordered configuration space* of M . The symmetric group \mathfrak{S}_r acts on $\tilde{\mathcal{C}}^r(M)$ by permuting the r points. Its quotient $\tilde{\mathcal{C}}^r(M)/\mathfrak{S}_r$ is called the *r*-th *unordered configuration space* and is denoted by $\mathcal{C}^r(M)$. The fundamental group of $\tilde{\mathcal{C}}^r(M)$ is the *pure braid group* $PB_r(M)$. The fundamental group of $\mathcal{C}^r(M)$ is the *braid group* $B_r(M)$.

In the next step we study an explicit generating set of the braid group $B_r(X)$. In Section 1.4 of [8], the generators of the pure braid group were determined as follows. Let $h : Y \rightarrow X$ be a K -sheeted, ramified, pointed covering of a Riemann surface X of topological type $S_{g,1}$ for $g \geq 0$ with branch points $p_1, \dots, p_r \in X$ disjoint from the dipole point Q . Further, let $X' = X - \bigcup_{1 \leq i \leq r} D_i$ where D_i are open pairwise disjoint disks containing p_i but not the dipole Q . The dipole point is fixed as the base point. Let a_i, b_i and c_j be curves in X' representing generators A_i, B_i and C_j of $\pi_1(X', Q)$ for $1 \leq i \leq g$ and $1 \leq j \leq r$ as introduced in Section 1.1. We assume c_j negatively oriented for making future calculations more tractable. As a

consequence, $\prod_{1 \leq i \leq g} [A_i, B_i] = \prod_{1 \leq j \leq r} C_j$. Let $u_{i,j}$ be a simple closed curve through p_j cutting a_i transversally, and analogously let $v_{i,j}$ be a simple closed curve through p_j cutting b_i transversally so that $u_{i,j}$ and $v_{i,j}$ are oriented in opposite directions. The curve $u_{i,j}$ is positively oriented while $v_{i,j}$ is negatively oriented with respect to the orientation of X . Moreover, $u_{i,j}$ and $v_{i,j}$ are constructed so that they do not intersect any other branch point. Let $w_{j,k}$ be a simple closed curve which is based in p_j and encloses only the branch point p_k such that neither p_l for $l \neq k$ nor the dipole point are enclosed. The elements of $PB_r(X)$ represented by $u_{i,j}$, $v_{i,j}$ and $w_{j,k}$ are enclosed. The elements of $PB_r(X)$ represented by $u_{i,j}$, $v_{i,j}$ and $w_{j,k}$ are denoted by $U_{i,j}$, $V_{i,j}$ and $W_{j,k}$, respectively (see Figure 1.5).

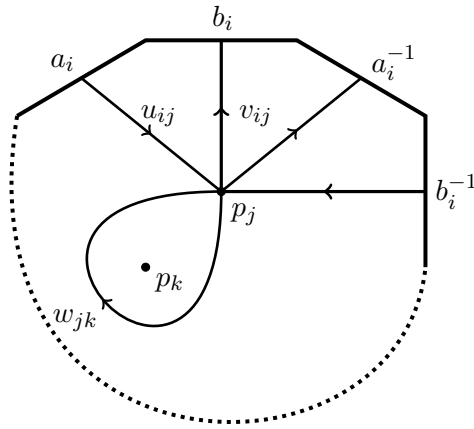

Figure 1.5: Generators of the braid group

Proposition 1.5.9 ([8]). *The elements $U_{i,j}$, $V_{i,j}$ and $W_{j,k}$ generate $PB_r(X)$ for $1 \leq j < k \leq r$ and $1 \leq i \leq g$.*

Next let us consider a deformation of the surface X as shown in Figure 1.6. Here, each path ω_i is homotopic to a loop which starts and ends in the base point Q , encloses only p_i as a branch point and does not intersect any p_j for $i \neq j$. Let $h_j : I \rightarrow X$ be the map which interchanges the branch points p_j

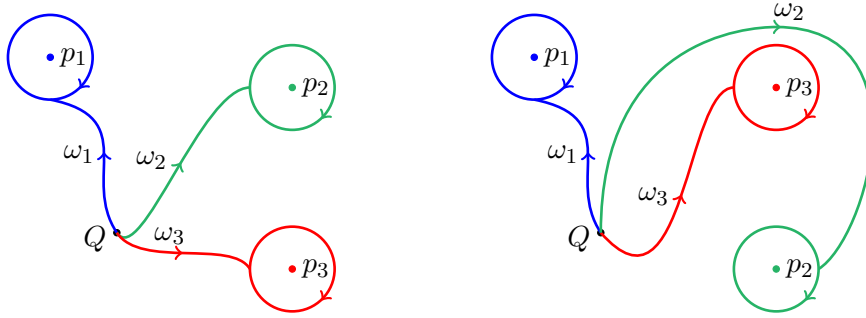

Figure 1.6: Commuting branch points

and p_{j+1} and is defined by a deformation as in Figure 1.6. Then h_j represents an element H_j of $PB_r(X)$. In Section 1.4 of [8] the identities

$$\begin{aligned}
 U_{i,j+1} &= H_j U_{i,j} H_j^{-1} \\
 V_{i,j+1} &= H_j V_{i,j} H_j^{-1} \\
 W_{j,k} &= H_k^{-1} \dots H_{j-2}^{-1} H_{j-1}^2 H_{j-2} \dots H_k
 \end{aligned}$$

were calculated. Because of Proposition 1.5.9 and the short exact sequence

$$0 \rightarrow PB_r(X) \rightarrow B_r(X) \rightarrow \mathfrak{S}_r \rightarrow 0$$

the braid group $B_r(X)$ is generated by $U_{i,j}$, $V_{i,j}$ and H_k for $1 \leq i \leq g$, $1 \leq j \leq r$ and $1 \leq k \leq r - 1$ (see Section 1.4 of [8]). Now the central idea to describe the action of the braid group on the set of monodromy representations is to determine the action of each generator of the braid group. To this end, we will prove the following proposition.

Proposition 1.5.10. *Let $h : Y \rightarrow X$ be a K -sheeted, ramified and pointed covering with branch points p_1, \dots, p_r where the dipole point $Q \in X$ is fixed as the base point. We assume that $Q \neq p_j$ for all $1 \leq j \leq r$. Moreover, let $A_i = [a_i]$, $B_i = [b_i]$ and $C_j = [c_j]$ be generators of the fundamental group of*

X' as before. We denote by d_i the product $[a_1, b_1] \dots [a_i, b_i]$ for $1 \leq i \leq g$. Then for all $1 \leq i \leq g$, $1 \leq j \leq r$ and $1 \leq k \leq r - 1$ the paths $u_{i,j}$, $v_{i,j}$ and h_k induce homotopies of X such that a_i , b_i and c_j are transformed by homotopies $a_{i,t}$, $b_{i,t}$ and $c_{j,t}$ whose end points $a_{i,1}$, $b_{i,1}$ and $c_{j,1}$ are as follows.

(1) For $1 \leq i \leq g$, $1 \leq j \leq r$ and $u_{i,j}$ the following identities are satisfied.

$$\begin{aligned} a_l &\cong a_{l,1} \text{ for all } 1 \leq l \neq i \leq g \text{ and } a_{i,1} = y_{i,j} c_j y_{i,j}^{-1} a_i, \\ b_i &\cong b_{i,1} \text{ for all } 1 \leq i \leq g, \\ c_{l'} &\cong c_{l',1} \text{ for all } 1 \leq l' \neq j \leq r \text{ and } c_{j,1} \cong \bar{y}_{i,j} c_j \bar{y}_{i,j}^{-1} \end{aligned}$$

where $y_{i,j} \cong d_{i-1}^{-1} c_1 \dots c_{j-1}$ and $\bar{y}_{i,j} \cong c_{j+1} \dots c_r d_g^{-1} d_i b_i d_{i-1}^{-1} c_1 \dots c_{j-1}$.

(2) For $1 \leq i \leq g$, $1 \leq j \leq r$ and $v_{i,j}$ the following identities are satisfied.

$$\begin{aligned} a_i &\cong a_{i,1} \text{ for all } 1 \leq i \leq g, \\ b_l &\cong b_{l,1} \text{ for all } 1 \leq l \neq i \leq g \text{ and } b_{i,1} \cong z_{i,j} c_j z_{i,j}^{-1} b_i, \\ c_{l'} &\cong c_{l',1} \text{ for all } 1 \leq l' \neq j \leq r \text{ and } c_{j,1} \cong \bar{z}_{i,j} c_j \bar{z}_{i,j}^{-1} \end{aligned}$$

where $\bar{z}_{i,j} \cong (c_1 \dots c_{j-1})^{-1} d_{i-1} a_i d_i^{-1} d_g (c_{j+1} \dots c_r)^{-1}$ and

$z_{i,j} \cong d_i^{-1} d_g (c_{j+1} \dots c_r)^{-1}$.

(3) For $1 \leq k \leq r - 1$ and h_k the following identities are satisfied.

$$\begin{aligned} a_l &\cong a_{l,1} \text{ and } b_l \cong b_{l,1} \text{ for all } 1 \leq l \leq g, \\ c_{l'} &\cong c_{l',1} \text{ for all } l' \neq k, k+1, \\ c_{k,1} &\cong c_{k+1} \text{ and } c_{k+1,1} \cong c_{k+1}^{-1} c_k c_{k+1}. \end{aligned}$$

Proof.

(1) The deformation of the loops c_j for $1 \leq j \leq r$ can be described as follows. The branch point p_j is translated along $u_{i,j}$ for $1 \leq i \leq g$.

Thus, the loop c_j is moved into the direction of a_i since it encloses only the branch point p_j . Before $c_{j,t}$ intersects a_i the path a_i has to be deformed since for every $t \in I$ there is no intersection between $c_{j,t}$ and $a_{i,t}$. But this deformation changes only c_j and a_i while all the other paths are preserved (see Figure 1.7).

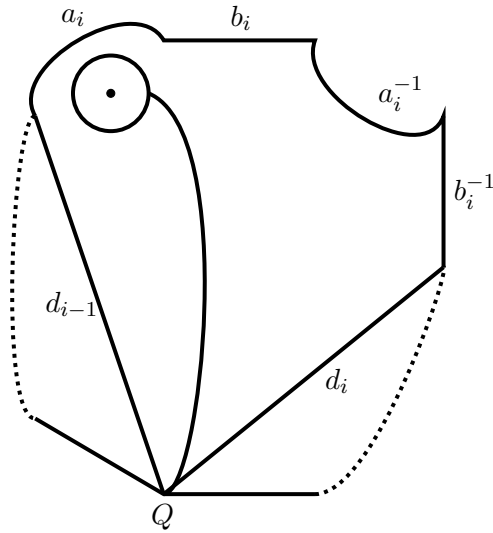

Figure 1.7: Deformation along $u_{i,j}$ in direction of a_i

The transformation for $a_{i,1}$ is now as follows. As p_j is not a point of a_i we may consider a loop $\kappa_{i,j}$ starting in a_i and enclosing p_j in positive direction (see Figure 1.8). Recall that $u_{i,j}$ was defined to be positively oriented.

The multiplication of consecutive loops c_j gives a big loop enclosing corresponding branch points in positive direction. So $\kappa_{i,j}$ can be expressed in terms of the loops c_j , that is, $d_{i-1}\kappa_{i,j}d_{i-1}^{-1}$ equals $c_1 \dots c_{j-1}c_j^{-1}(c_1 \dots c_{j-1})^{-1}$. Thus, the formula for $y_{i,j}$ is satisfied (see Figure 1.9).

For $\bar{y}_{i,j}$ the considerations are similar, that is, we have to express $\bar{y}_{i,j}$ in

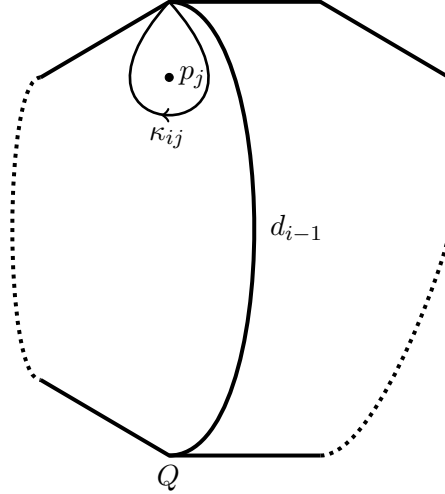

Figure 1.8: Loop $\kappa_{i,j}$

terms of the given loops. Let $l_{i,j}$ be a loop that intersects a_i transversally and does not intersect any branch points while p_j is passed in negative direction and p_{j+1} in positive direction. Then $l_{i,j}$ is given by $(c_1 \dots c_j)^{-1} d_i b_i d_{i-1}^{-1} c_1 \dots c_j$. Consequently, the identity for $\bar{y}_{i,j}$ holds when applying the equation $c_1 \dots c_r = d_g$.

- (2) The calculations for (2) work analogously by interchanging a_i with b_i and reversing the direction of the constructed loops.
- (3) Since only c_j and c_{j+1} are interchanged the formulas follow by the same considerations as in (2) of Theorem 1.5.5.

□

By means of Proposition 1.5.10, we are in a position to characterize the action of the braid group on the set of monodromy representations. For technical reasons, we identify every monodromy representation with its image $(\alpha_1, \dots, \alpha_g, \beta_1, \dots, \beta_g, \gamma_1, \dots, \gamma_r)$ on the fixed generating set of the fundamental group $\pi_1(X')$.

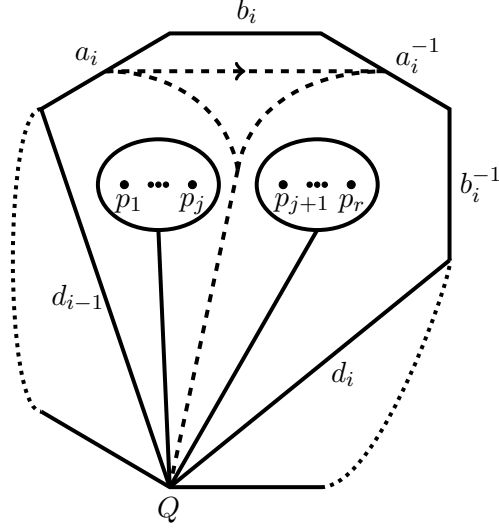

Figure 1.9: Representing $\kappa_{i,j}$

Theorem 1.5.11. *The group generated by $U_{i,j}$, $V_{i,j}$ and H_k acts on the set of all monodromy types $(\alpha_1, \dots, \alpha_g, \beta_1, \dots, \beta_g, \gamma_1, \dots, \gamma_r)$ as follows. In particular, the orbits of this action correspond to the connected components of $\mathcal{H}_r(X)[K]$. We set $\delta_i = [\alpha_1, \beta_1] \dots [\alpha_i, \beta_i]$ and we denote by $\alpha_{i,1}$, $\beta_{i,1}$ and $\gamma_{i,1}$ the transformed entries of the monodromy type.*

(1) For $1 \leq i \leq g$, $1 \leq j \leq r$ and $U_{i,j}$ the following identities are satisfied.

$$\alpha_l = \alpha_{l,1} \text{ for all } 1 \leq l \neq i \leq g \text{ and } \alpha_{i,1} = \eta \gamma_j \eta^{-1} \alpha_i,$$

$$\beta_i = \beta_{i,1} \text{ for all } 1 \leq i \leq g,$$

$$\gamma_{l'} = \gamma_{l',1} \text{ for } 1 \leq l' \neq j \leq r \text{ and } \gamma_{j,1} = \bar{\eta} \gamma_j \bar{\eta}^{-1}$$

where $\eta = \delta_{i-1}^{-1} \gamma_1 \dots \gamma_{j-1}$ and $\bar{\eta} = \gamma_{j+1} \dots \gamma_r \delta_g^{-1} \delta_i \beta_i \delta_{i-1}^{-1} \gamma_1 \dots \gamma_{j-1}$.

(2) For $1 \leq i \leq g$, $1 \leq j \leq r$ and $V_{i,j}$ the following identities are satisfied.

$$\begin{aligned}\alpha_i &= \alpha_{i,1} \text{ for all } 1 \leq i \leq g, \\ \beta_l &= \beta_{l,1} \text{ for all } 1 \leq l \neq i \leq g \text{ and } \beta_{i,1} = \xi \gamma_j \xi^{-1} \beta_i, \\ \gamma_{l'} &= \gamma_{l',1} \text{ for all } 1 \leq l' \neq j \leq r \text{ and } \gamma_{j,1} = \bar{\xi} \gamma_j \bar{\xi}^{-1}\end{aligned}$$

where $\bar{\xi} = (\gamma_1 \dots \gamma_{j-1})^{-1} \delta_{i-1} \alpha_i \delta_i^{-1} \delta_g (\gamma_{j+1} \dots \gamma_r)^{-1}$ and
 $\xi = \delta_i^{-1} \delta_g (\gamma_{j+1} \dots \gamma_r)^{-1}$.

(3) For $1 \leq k \leq r - 1$ and H_k the following identities are satisfied.

$$\begin{aligned}\alpha_{i,1} &= \alpha_i \text{ and } \beta_{i,1} = \beta_i \text{ for all } 1 \leq i \leq g, \\ \gamma_{j,1} &= \gamma_j \text{ for all } j \neq k, k+1, \\ \gamma_{k,1} &= \gamma_{k+1} \text{ and } \gamma_{k+1,1} = \gamma_{k+1}^{-1} \gamma_k \gamma_{k+1}.\end{aligned}$$

The proof of this theorem follows directly from Proposition 1.5.10.

Chapter 2

The Hilbert uniformization of flat G -bundles

2.1 Preliminaries to the Hilbert uniformization

In this section we will introduce moduli spaces of flat pointed G -bundles over Riemann surfaces with a dipole point and a finite number of punctures.

Remark 2.1.1. Surfaces with punctures arise from compact surfaces with marked points by deleting them. More precisely, let S be a compact surface with $m \geq 1$ marked points P_1, \dots, P_m . Then we call $S' = S - \{P_1, \dots, P_m\}$ a surface with punctures P_1, \dots, P_m . The mapping class groups of S and S' are isomorphic. In fact, a conformal homeomorphism $h' : S'_1 \rightarrow S'_2$ between two surfaces with $m \geq 1$ punctures has an extension to a conformal homeomorphism $h : S_1 \rightarrow S_2$ between the respective surfaces with marked points (see Theorem 17.3 of [52]). The map h fixes the set of marked points not necessarily pointwise. Since h may permute the marked points we call the punctures of the conformal equivalence class *permutable* and say that h' preserves punctures.

The reason for introducing surfaces with punctures in this chapter in contrast to the previous sections where we considered marked points is that the holonomy around a puncture is not necessarily trivial. Every arbitrarily small neighborhood of a puncture is not simply connected. On the other hand, there is always a sufficiently small open simply connected neighborhood of a marked point so that the holonomy has to be trivial there.

Finally, we should point out the difference between surfaces with punctures to surfaces with boundary components. Let S be a closed surface with marked points P_1, \dots, P_m and let $S' = S - \{P_1, \dots, P_m\}$. For each $1 \leq i \leq m$ let D_i be an open disk containing P_i such that $\bar{D}_i \cap \bar{D}_j = \emptyset$ for all $i \neq j$. Then $S'' = S - \coprod_{1 \leq i \leq m} D_i$ is a compact surface with m boundary components. The surfaces S' and S'' are neither diffeomorphic nor are their mapping class groups isomorphic. We assume representatives of mapping classes to fix boundary components pointwise but to permute punctures. In addition, representatives of mapping classes may rotate a neighborhood of a puncture while they have to fix boundary components. Without going into further details we refer to Section 17 of [52] and [7] for a discussion from an analytical viewpoint.

Definition 2.1.2. Let $S_{g,n}^{(m)}$ be a connected, oriented surface of genus $g \geq 0$ with $m \geq 0$ punctures P_1, \dots, P_m and $n \geq 1$ directed points $(Q_1, \chi_1), \dots, (Q_n, \chi_n)$. To lighten notation we set $\mathcal{P} = \{P_1, \dots, P_m\}$ and $\mathcal{Q} = ((Q_1, \chi_1), \dots, (Q_n, \chi_n))$. The moduli space $\mathcal{M}_{g,n}^{(m)}$ consists of conformal equivalence classes of 2-dimensional, oriented, connected manifolds with this data. Two such surfaces X and X' are equivalent if there exists a conformal homeomorphism $\phi : X \rightarrow X'$ such that ϕ preserves punctures, $\phi(Q_i) = Q'_i$ and $d\phi(\chi_i) = \chi'_i$ for all $1 \leq i \leq n$. Then a point in $\mathcal{M}_{g,n}^{(m)}$ is denoted by $\mathcal{F} = [X, P_1, \dots, P_m, (Q_1, \chi_1), \dots, (Q_n, \chi_n)]$ or shortly by $\mathcal{F} = [X, \mathcal{P}, \mathcal{Q}]$ as

in Definition 1.2.1.

Using the same notation in Definition 1.2.1 and Definition 2.1.2 is justified by Remark 2.1.1.

Definition 2.1.3. Let (E, π, X, A) be a flat pointed G -bundle where X is a Riemann surface of genus $g \geq 0$ with $m \geq 0$ permutable punctures P_1, \dots, P_m and a dipole (Q, χ) which is fixed as the base point. Moreover, let $p_0 \in E_Q$ be a base point. The moduli space $\mathcal{M}_{g,1}^{(m)}(G)$ consists of equivalence classes of smooth, flat, pointed G -bundles over Riemann surfaces with the above structure. Two flat pointed G -bundles $(E, \pi, X, A, \mathcal{P}, \mathcal{Q}, p_0)$ and $(E', \pi', X', A', \mathcal{P}', \mathcal{Q}', p'_0)$ are equivalent if the following conditions are satisfied. There exists a conformal homeomorphism $\phi : X \rightarrow X'$ such that ϕ preserves punctures, $\phi(Q_i) = Q'_i$ and $d\phi(\chi_i) = \chi'_i$ for all $1 \leq i \leq n$. Moreover, there is a fiber preserving pointed diffeomorphism $f : E \rightarrow E'$ such that $f_*A = A'$ and $\pi' \circ f = \phi \circ \pi$. We call $\mathcal{M}_{g,1}^{(m)}(G)$ the *moduli space of flat G -bundles over Riemann surfaces with punctures*. A point in $\mathcal{M}_{g,1}^{(m)}(G)$ is denoted by $[E, \pi, X, A, \mathcal{P}, \mathcal{Q}, p_0]$ which we usually abbreviate as $[E, \pi, X, A]$.

The topology of $\mathcal{M}_{g,1}^{(m)}(G)$ is defined analogously as the topology of $\mathcal{M}_{g,1}^m(G)$ in Section 1.2. According to Remark 2.1.1 the moduli spaces $\mathcal{M}_{g,1}^m$ and $\mathcal{M}_{g,1}^{(m)}$ are homeomorphic. Applying the same arguments as in Lemma 1.2.8 it follows that $\mathcal{M}_{g,1}^{(m)}(G)$ is as a set in one-to-one correspondence with the fiber product $\mathcal{T}_{g,1}^m \times_{\Gamma_{g,1}^m} \mathcal{R}_G(S_{g,1}^{(m)})$. Hence, we assume on $\mathcal{M}_{g,1}^{(m)}(G)$ the quotient topology of the direct product of the Teichmüller space and the representa-

tion variety. As a consequence, the diagram

$$\begin{array}{ccc}
\mathcal{R}_G(S_{g,1}^m) & \longrightarrow & \mathcal{R}_G(S_{g,1}^{(m)}) \\
\downarrow & & \downarrow \\
\mathcal{M}_{g,1}^m(G) & \longrightarrow & \mathcal{M}_{g,1}^{(m)}(G) \\
\Phi(G) \downarrow & & \downarrow \Phi(G) \\
\mathcal{M}_{g,1}^m & \longrightarrow & \mathcal{M}_{g,1}^{(m)}
\end{array}$$

commutes. The vertical sequences are fiber bundles and the horizontal arrows are inclusions so that the following Lemmas are satisfied. As no confusion is possible we call the projection to the moduli space of Riemann surfaces $\Phi(G)$ in both cases.

Lemma 2.1.4. *The inclusion $\mathcal{M}_{g,1}^m(G) \rightarrow \mathcal{M}_{g,1}^{(m)}(G)$ is an embedding of moduli spaces. This mapping is a homeomorphism for $m = 0$.*

Lemma 2.1.5. *The canonical projection $\Phi(G) : \mathcal{M}_{g,1}^{(m)}(G) \rightarrow \mathcal{M}_{g,1}^{(m)}$ is a fiber bundle with fiber G^{2g+m-1} if $m \geq 1$ and $\mathcal{R}_G(S_{g,1})$ for $m = 0$.*

Proof. For $m = 0$ the assertion follows from Lemmas 1.2.8 and 2.1.4. Therefore, let us assume that $m \geq 1$ so that $\mathcal{R}_G(S_{g,1}^{(m)})$ is isomorphic to $\{(A_1, \dots, A_g, B_1, \dots, B_g, C_1, \dots, C_m) \mid \prod_{i=1}^g [A_i, B_i] \prod_{j=1}^m C_j = 1\}$ after fixing a generating set for $\pi_1(S_{g,1}^{(m)})$. From this representation it follows that $\mathcal{R}_G(S_{g,1}^{(m)})$ is isomorphic to G^{2g+m-1} .

□

Corollary 2.1.6. *The moduli space $\mathcal{M}_{g,1}^{(m)}(G)$ is a topological manifold if $m \geq 1$ or if the conditions of Corollary 1.2.10 are satisfied.*

2.2 Construction of the Hilbert uniformization

By means of the Hilbert uniformization of Riemann surfaces, a simplicial complex was constructed in [9] which is homotopy equivalent to the moduli space $\mathcal{M}_{g,1}^m$. One of our central objectives is to generalize this method to the *Hilbert uniformization of flat G -bundles* over Riemann surfaces in order to construct a simplicial complex which is homotopy equivalent to $\mathcal{M}_{g,1}^{(m)}(G)$. Then the Hilbert uniformization of Riemann surfaces will correspond to the case of G being the trivial group. First we will repeat the most important facts about the Hilbert uniformization of Riemann surfaces. For further details see [9], or [23] for a more general approach.

Let X be a Riemann surface of genus $g \geq 0$ with $m \geq 0$ punctures P_1, \dots, P_m and a dipole $Q \in X$ with a nonzero tangent vector χ . Recall that X arises from a closed Riemann surface with a dipole point for which m marked points are deleted. A conformal equivalence class is denoted by $\mathcal{F} = [X, P_1, \dots, P_m, Q, \chi]$ as in Definition 2.1.2. For each Riemann surface with this data given and positive real constants b, c_1, \dots, c_m such that $\sum_{1 \leq j \leq m} c_j = b$ there exists a *potential function* $u : X \rightarrow \overline{\mathbb{R}}$. A potential function is characterized by the following properties. It is harmonic on $X - \{P_1, \dots, P_m, Q\}$. Let (U, z) be a chart of Q with $z(Q) = 0$ and $dz(\chi) = 1$ then u is locally of the form

$$u(z) = \Re\left(\frac{1}{z}\right) - b \Re(\log(z)) + f(z),$$

where $f : U \rightarrow \mathbb{R}$ is harmonic. Moreover, for each $1 \leq j \leq m$ let (U, z) be a chart of P_j with $z(P_j) = 0$ then u is locally the form

$$u(z) = c_j \Re(\log(z)) + f_j(z),$$

where $f_j : U \rightarrow \mathbb{R}$ is harmonic. A potential function is uniquely determined by the above data up to an additive constant (see Section 3.1 of [9]).

Definition 2.2.1. The *moduli space of potential functions* on Riemann surfaces $\mathfrak{H}_{g,1}^m$ consists of equivalence classes of Riemann surfaces X of genus $g \geq 0$ with $m \geq 0$ punctures P_1, \dots, P_m , a dipole point $Q \in X$ with a nonzero tangent vector χ , and a potential function $u : X \rightarrow \overline{\mathbb{R}}$. Two surfaces with potential function $(X, P_1, \dots, P_m, Q, \chi, u)$ and $(X', P'_1, \dots, P'_m, Q', \chi', u')$ are equivalent if the following conditions are satisfied. There is a conformal homeomorphism $\phi : X \rightarrow X'$ which preserves the set of punctures, $\phi(Q) = Q'$, $d\phi(\chi) = \chi'$ and $u' \circ \phi = u$.

The following result is the starting point for the Hilbert uniformization (see Section 5.1 of [9]).

Lemma 2.2.2. *The canonical projection $\mathfrak{H}_{g,1}^m \rightarrow \mathcal{M}_{g,1}^m$ is an affine bundle of dimension $m + 1$. In particular, $\mathfrak{H}_{g,1}^m$ is homotopy equivalent to $\mathcal{M}_{g,1}^m$.*

For a potential function u , let $\xi = -\text{grad}(u)$ be the gradient vector field of u . The punctures P_1, \dots, P_m are sinks of the gradient vector field. Moreover, trajectories leave the dipole point Q in direction of χ . By means of these considerations, we define the following notion.

Definition 2.2.3. The *critical graph* \mathcal{K} has $\{P_1, \dots, P_m, Q\}$ and the critical points of u as the set of vertices. The set of edges is given by the trajectories of the gradient vector field from a critical point into the dipole or into a puncture, or into another critical point. More precisely, an edge exists between two of these vertices if there is a trajectory between them, which is a flow line of the gradient vector field ξ of u .

The *extended critical graph* $\hat{\mathcal{K}}$ has the same set of vertices as the critical

graph \mathcal{K} . Edges are induced by the trajectories from the dipole into a critical point, between two critical points or from a critical point into the dipole or into a puncture.

The sets of edges leaving and entering the same vertex admit cyclic orderings which are induced by the orientation of the surface. The complement $X - \mathcal{K}$ is a simply connected domain where u is harmonic. By the lemma of Poincaré u is the real part of a holomorphic function $w = u + \sqrt{-1}v$ which is uniquely determined up to an additive constant. The image of w is a so-called *parallel slit domain* (PSD). It is the complex plane cut along horizontal slits (parallel to the x -axis) that come from minus infinity and end in some point z in the complex plane. An example of a parallel slit domain is shown in Figure 2.1.

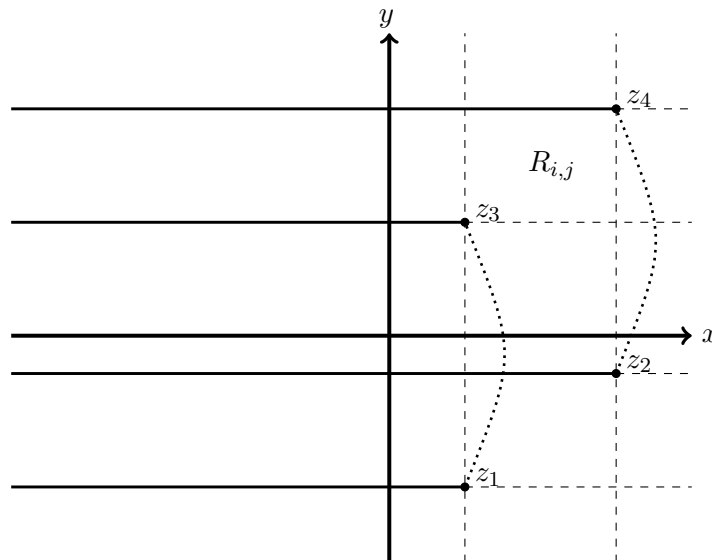

Figure 2.1: Parallel Slit Domain

Since u is the real part and v the imaginary part of w , the values of the critical points of u and v correspond to the x -values and y -values of the slit end points, respectively. Note that v is defined as a function only on $X - \mathcal{K}$. On the other hand, we may consider v as a differential form on the whole

space X so that the notion of critical points of v is also meaningful in this sense. In the generic case, we assume that all critical points are nondegenerate, lie on different critical levels and every trajectory of ξ which comes from a critical point goes directly into the dipole without passing another critical point. Hence, the slits occur in pairs and do not intersect (see Figure 2.1). In the nongeneric case, several pairs of slits may lie on the same level or slits may intersect.

We subdivide the PSD into polygons by means of a grid consisting of horizontal and vertical lines in the complex plane. For reasons which become apparent later we call these polygons *rectangles* although not all of those have this shape. The horizontal lines of the grid are defined by the slits and their prolongations to plus infinity, while the vertical lines pass through the slit ends parallel to the y -axis. We number the columns of the grid from the right hand side to the left hand side and the rows from the bottom to the top starting in both cases with zero. The rectangle lying in the i -th column and j -th row is denoted by $R_{i,j}$ for $0 \leq i \leq q$ and $0 \leq j \leq p$ while the possible ranges are $0 \leq q \leq h$ and $0 \leq p \leq 2h$ where $h = 2g + m$ (see [1] for a precise discussion of the dimensions). In the generic case we have $q = h$ and $p = 2h$ (see Figure 2.1). From the surface geometry we obtain unique permutations $\sigma_i \in \mathfrak{S}_p^0$ for each column of the grid ($0 \leq i \leq q$) which can be applied to reglue the parallel slit domain into a Riemann surface. More precisely, we consider a so-called *extended* parallel slit domain which is the disjoint union of all closed rectangles defined by the grid. Then the gluing rules are as follows.

The upper side of $R_{i,j}$ is glued to the lower side of $R_{i,\sigma_i(j)}$ and the left hand side of $R_{i,j}$ is glued to the right hand side of $R_{i+1,j}$. Finally, one point must be added at infinity which is the dipole point.

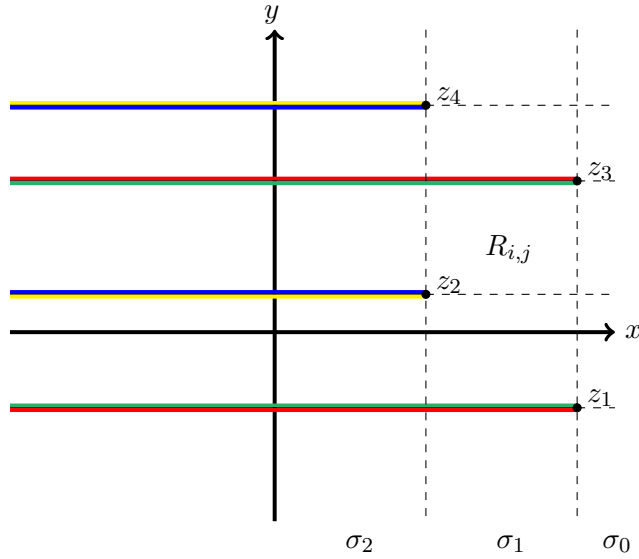

Figure 2.2: Gluing rules of a PSD

For instance, the gluing process is visualized for a generic configuration in Figure 2.2. In this example, z_1 and z_3 as well as z_2 and z_4 are identified to one nondegenerate critical point of u in each case. The permutations σ_0 , σ_1 and σ_2 represent the combinatorial data of the surface. Note that the decomposition of a PSD into $p+1$ stripes with respect to the horizontal lines of the grid is the complement of the extended critical graph $X - \hat{\mathcal{K}}$. Now, the construction can be reversed by gluing the rectangles of an extended PSD (as described above) to obtain a Riemann surface. The extended PSD and the gluing permutations cannot be chosen arbitrarily. We will discuss the precise conditions shortly.

In Chapter 4 of [9], a complex atlas for the surface X was constructed using the grid on the corresponding PSD. Since we do not go into details of this construction we discuss the main ideas by means of Figure 2.3 exemplarily. The following cases have to be distinguished. For the point z in the interior of a rectangle a chart W is established by the interior of this rectangle. It

is mapped homeomorphically into \mathbb{C} by a homeomorphism $\phi : W \rightarrow V \subseteq \mathbb{C}$ where V is an open rectangle. The set W is redly colored in Figure 2.3. Next we consider a point z' lying in the interior of a rectangle's edge (see Figure 2.3). It is identified with the point z'' to one point $x \in X$. The two blue semicircles as in Figure 2.3 may be used to construct a chart containing $x \in X$. They are mapped homeomorphically into \mathbb{C} . After possibly translating the images in the complex plane they are identified along their diameters to an open disk. The homeomorphisms on each semicircle determine a common homeomorphism from an open disk containing $x \in X$ to an open disk in \mathbb{C} . For points z_1 and z_3 which are identified to one point $x' \in X$ and lie on the corners of rectangles as in Figure 2.3 we proceed analogously. We consider the two yellow slit disks that are mapped homeomorphically into \mathbb{C} by $\zeta \mapsto \zeta^2$. The images are two semicircles which are identified along their diameters to an open disk (after possibly translating them appropriately). Such homeomorphisms on each slit disk determine a homeomorphism from an open disk containing $x' \in X$ to an open disk in \mathbb{C} . The chart of the dipole point Q is constructed similarly. To this end, we consider the green region in Figure 2.3. It is fully contained inside all rectangles having nonempty intersection with Q . It is mapped homeomorphically to \mathbb{C} where the sides of the rectangles are identified as prescribed by the permutations $\Sigma = (\sigma_q, \dots, \sigma_0)$. By adding one point at infinity we obtain the chart of Q . This point at infinity will be the dipole point. Finally, charts can be constructed analogously for each puncture by considering exactly those rectangles which contain the puncture. So in case of the punctures, the construction details are omitted. We denote such a complex atlas obtained by means of the Hilbert uniformization by $\{W_\alpha, \phi_\alpha\}$.

In the next step we will indicate how to construct a simplicial space which

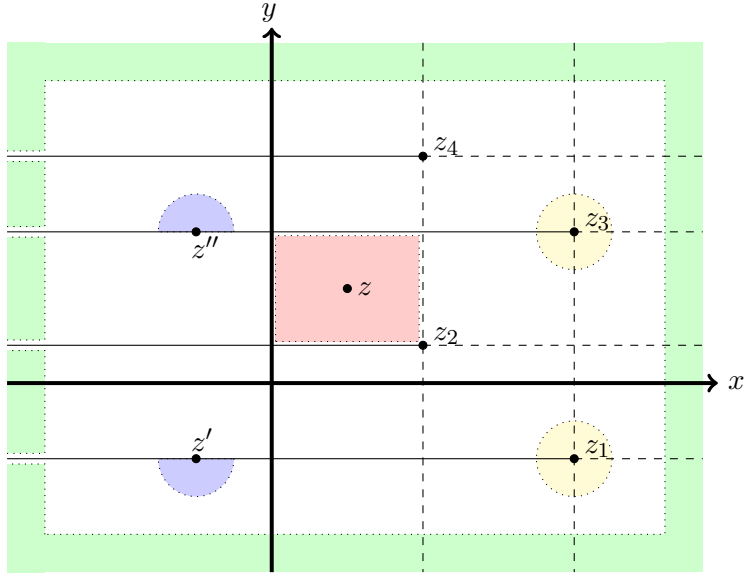

Figure 2.3: Complex atlas

is homeomorphic to $\mathfrak{H}_{g,1}^m$. For this, it will be necessary to explain how to define the simplices and to state the right conditions imposed on the gluing permutations. As motivated geometrically the identification of the simplices will be given by the gluing conditions of the extended parallel slit domains. First we will determine the simplices. We identify \mathbb{R} with the open unit interval. The extended PSD is transformed into a slit unit square whose horizontal slits start on the left hand side and end in some point in the interior of the unit square. In the generic case, the slits occur in pairs of equal lengths and do not intersect. The values of the critical points of u and v induce barycentric coordinates $(a_i, b_j)_{i,j}$ by computing their differences. They will serve as coordinates of the simplices we are looking for. The indices range as $0 \leq i \leq q$, $0 \leq j \leq p$ while $0 \leq q \leq h$ and $0 \leq p \leq 2h$. We consider the grid described above on the slit unit square (see Figure 2.4). We denote again by $R_{i,j}$ the rectangle lying in the i -th column and j -th row of the grid as depicted in Figure 2.4. The slit unit square with the

grid, barycentric coordinates and gluing permutations (as shown in Figure 2.4) is called a *parallel slit model* (PSM). It encodes the combinatorial type of a Riemann surface with potential function. So we will sometimes refer to a PSM as the *combinatorial surface type*. Let \mathfrak{S}_p^0 denote the symmetric group on $\{0, \dots, p\}$. Assume that for $0 \leq q \leq h$ and $0 \leq p \leq 2h$ barycentric coordinates $(a_i, b_j)_{i,j}$ for $0 \leq i \leq q$, $0 \leq j \leq p$ and permutations $\sigma_i \in \mathfrak{S}_p^0$ are given. Note that this data determines a PSM and thus an extended PSD uniquely.

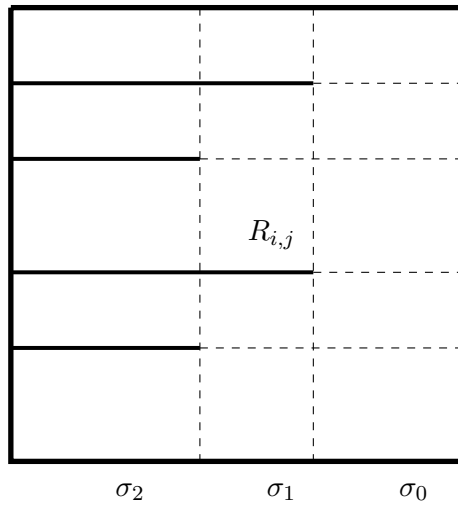

Figure 2.4: Parallel Slit Model

The gluing permutations $\Sigma = (\sigma_q : \dots : \sigma_0)$ cannot be chosen arbitrarily as we have noted before. To determine the permitted configurations we introduce the following definition.

Definition 2.2.4. A *normed group* is a pair (G, N) where G is a group and $N : G \rightarrow \mathbb{N}_0$ is a function such that the following conditions are satisfied.

- (NG1) For all $g \in G$ we have $N(g) = 0 \Rightarrow g = 1$.
- (NG2) For all $g \in G$ we have $N(g) = N(g^{-1})$.

(NG3) For all $g_1, g_2 \in G$ we have $N(g_1g_2) \leq N(g_1) + N(g_2)$.

Example 2.2.5. Let \mathfrak{S}_n be the symmetric group on $\{1, \dots, n\}$ and let \mathfrak{S}_n^0 be the symmetric group on the set $\{0, \dots, n\}$. The set of all transpositions is a generating set for both groups. The so-called *word length norm* $wl(\sigma)$ for $\sigma \in \mathfrak{S}_n$ or $\sigma \in \mathfrak{S}_n^0$ is defined as the minimal number of transpositions whose product is σ . The word length norm is a norm in the sense of Definition 2.2.4.

Using the word length norm of Example 2.2.5, we define the norm N of $\Sigma = (\sigma_q : \dots : \sigma_0)$ by $N(\Sigma) = wl(\sigma_q \circ \sigma_{q-1}^{-1}) + \dots + wl(\sigma_1 \circ \sigma_0^{-1})$. Let $ncyc(\sigma)$ be the number of cycles from the disjoint cycle decomposition of the permutation σ . The first two conditions imposed on $\Sigma = (\sigma_q : \dots : \sigma_0)$ are the following.

(NZ1) For all $\Sigma = (\sigma_q : \dots : \sigma_0)$ we have $N(\Sigma) \leq h$.

(NZ2) For all $\Sigma = (\sigma_q : \dots : \sigma_0)$ we have $ncyc(\sigma_q) \leq m + 1$.

Remark 2.2.6. Let $\Sigma = (\sigma_q : \dots : \sigma_0)$ and $\tau_i = \sigma_i \circ \sigma_{i-1}^{-1}$ for $1 \leq i \leq q$. We call $\mathcal{T} = (\tau_q | \dots | \tau_1)$ the *inhomogeneous* notation and $\Sigma = (\sigma_q : \dots : \sigma_0)$ the *homogeneous* notation. Then (NZ1) and (NZ2) are equivalent to the following conditions which will be sometimes more natural to work with.

(NIZ1) For all $\mathcal{T} = (\tau_q | \dots | \tau_1)$ we have $\sum_{i=1}^q wl(\tau_i) \leq h$.

(NIZ2) For all $\mathcal{T} = (\tau_q | \dots | \tau_1)$ we have $ncyc(\tau_q \dots \tau_1 \sigma_0) = ncyc(\sigma_q) \leq m + 1$.

Notation. Let $D_j : \mathfrak{S}_{p+1}^0 \rightarrow \mathfrak{S}_p^0$ be the map which deletes the figure j from each cycle of a permutation and re-indexes it afterwards for $0 \leq j \leq p$. To be precise, let $d_j : \{0, \dots, p\} \rightarrow \{0, \dots, p+1\}$ and $s_j : \{0, \dots, p\} \rightarrow \{0, \dots, p-1\}$ be the standard simplicial maps. Then $D_j(\alpha) = s_j \circ (\alpha(j), j) \circ \alpha \circ d_j$ for

$\alpha \in \mathfrak{S}_p^0$ and satisfy the simplicial identities for $0 \leq j \leq p$.¹ Note that the maps D_j are not group homomorphisms.

Definition 2.2.7. Let $\mathbb{P}_{p,q}$ be the free abelian group generated by elements of $(\mathfrak{S}_p^0)^{q+1}$ which satisfy (NZ1) and (NZ2). Set $\mathbb{P} = \bigoplus \mathbb{P}_{p,q}$ for $0 \leq p \leq 2h$ and $0 \leq q \leq h$ where $h = 2g + m$. Then \mathbb{P} obtains the structure of a chain complex if equipped with a boundary map $\partial = \partial' + (-1)^q \partial''$ given by

$$\partial' = \sum_{i=0}^q (-1)^i \partial'_i, \text{ where } \partial'_i(\sigma_q : \dots : \sigma_0) = (\sigma_q : \dots : \widehat{\sigma}_i : \dots : \sigma_0),$$

$$\partial'' = \sum_{j=0}^p (-1)^j \partial''_j, \text{ where } \partial''_j(\sigma_q : \dots : \sigma_0) = (D_j(\sigma_q) : \dots : D_j(\sigma_0)).$$

The maps ∂'_i and ∂''_j satisfy the simplicial identities. Hence, $(\mathbb{P}_{p,q}, \partial'_i, \partial''_j)_{p,q,i,j}$ establishes a bisimplicial set. We denote by $\text{Par}_{g,1}^m$ its geometric realization. It admits the natural topology of a simplicial space (see Section 14 of [41]).

Note that the maps ∂' and ∂'' commute so that 2.2.7 is well-defined. In the next step, we will specify a homeomorphism between a subset of $\text{Par}_{g,1}^m$ and $\mathfrak{H}_{g,1}^m$. This homeomorphism is called the *Hilbert uniformization of Riemann surfaces*. For further details we refer to Section 5 in [9]. Since there exist configurations which induce degenerated surfaces the whole space $\text{Par}_{g,1}^m$ cannot be homeomorphic to $\mathfrak{H}_{g,1}^m$. See Section 4.4 of [11] for numerous counterexamples. It remains to exclude wrong gluing permutations. For this we introduce the following conditions according to [1].

(S1) For all $0 \leq i \leq q$ we have $\sigma_i(p) = 0$.

(S2) The permutation σ_0 is the cycle $\omega_p = (0, \dots, p)$.

¹The j -th degeneracy map $\mathfrak{S}_p^0 \rightarrow \mathfrak{S}_{p+1}^0$ introduces the figure j as a fixpoint for each permutation and re-indexes it afterwards.

(S3) For all $0 \leq i \leq q$ we have $\sigma_{i+1} \neq \sigma_i$.

(S4) There is no $j \in \{0, \dots, p-1\}$ such that $\sigma_i(j) = j+1$ for all $0 \leq i \leq q$.

Definition 2.2.8. Let $\text{Par}'_{g,1}{}^m$ be the subcomplex consisting of elements of $\text{Par}_{g,1}{}^m$ which do not satisfy all of (S1)-(S4). We call $\text{Par}'_{g,1}{}^m$ the complex of *degenerated cells* and its complement $\mathfrak{P}_{g,1}{}^m$ the *nondegenerated* part of $\text{Par}_{g,1}{}^m$.

It was shown in Chapter 4 of [9] that $\text{Par}'_{g,1}{}^m$ is a subcomplex so that $\mathfrak{P}_{g,1}{}^m$ is open.

Theorem 2.2.9 ([9]). *The moduli space $\mathfrak{M}_{g,1}{}^m$ is homeomorphic to $\mathfrak{P}_{g,1}{}^m$ for all $g \geq 0$ and $m \geq 0$.*

See also [23] for an extension and [49] for further discussion of this theorem. Now we will generalize the Hilbert uniformization to investigate the moduli space $\mathcal{M}_{g,1}^{(m)}(G)$ for a fixed Lie group G . The idea is analogous to the Hilbert uniformization of Riemann surfaces except that the flat principal G -bundle structure has to be considered. More precisely, we will introduce a method to transform flat G -bundles over Riemann surfaces into the trivial G -bundle over the corresponding parallel slit domains. For the inversion of this uniformization, we introduce gluing conditions for the trivial G -bundle over an extended parallel slit domain in order to construct a flat principal G -bundle over a Riemann surface. The gluing data will determine the flat G -bundle structure and complex structure of the surface uniquely.

Let $Z \in \text{Par}_{g,1}{}^m$, that is, Z is of the form $((a_i, b_j)_{i,j}, \Sigma)$ where $(a_i, b_j)_{i,j}$ are barycentric coordinates and $\Sigma = (\sigma_q : \dots : \sigma_0)$ for $\sigma_i \in \mathfrak{S}_p^0$ where $0 \leq p \leq 2h$ and $0 \leq q \leq h$. If $Z \in \mathfrak{P}_{g,1}{}^m$ there is an extended PSD Y such that Y/\sim is a Riemann surface with m punctures and one dipole point. The identification \sim corresponds to the gluing along the upper and lower sides of the

rectangles given by Σ as described before. We consider the product $Y \times G$ and elements $\gamma_{i,j} \in G$ for $0 \leq i \leq q$ and $0 \leq j \leq p$. Let $R_{i,j}^\xi$ be the rectangle $R_{i,j} \times \{\xi\} \subseteq Y \times G$ for $\xi \in G$. The upper side of $R_{i,j}^\xi$ is identified with the lower side of $R_{i,\sigma_i(j)}^{\gamma_{i,j}^\xi}$. The left hand side of $R_{i,j}^\xi$ is identified with the right hand side of $R_{i+1,j}^\xi$. We denote this identification by \approx . Next we have to find the gluing conditions for Z and $(\gamma_{i,j})_{i,j}$ such that $Y \times G / \approx$ is a flat G -bundle over Y / \sim .

To this end, let S be an element of the wreath product $G \wr \mathfrak{S}_p^0 = G^{p+1} \rtimes \mathfrak{S}_p^0$ such that $S = (\gamma_p, \dots, \gamma_0; \sigma)$ with $\gamma_j \in G$ for $0 \leq j \leq p$ and $\sigma \in \mathfrak{S}_p^0$. The symmetric group \mathfrak{S}_p^0 acts from the left on G^{p+1} by

$$\sigma \cdot (\gamma_p, \dots, \gamma_0) = (\gamma_{\sigma(p)}, \dots, \gamma_{\sigma(0)})$$

where $\sigma \in \mathfrak{S}_p^0$ and $\gamma_j \in G$ for $0 \leq j \leq p$. In fact, for all further wreath products we shall assume actions from the left. Moreover, the group G acts on itself by left multiplication. We define an action of $G \wr \mathfrak{S}_p^0$ on $\{0, \dots, p\} \times G$ by $S \cdot (j, \xi) = (\sigma(j), \gamma_j \xi)$ for $\gamma_j, \xi \in G$, $0 \leq j \leq p$ and $\sigma \in \mathfrak{S}_p^0$. The canonical projection of groups is denoted by $\Pi : G \wr \mathfrak{S}_p^0 \rightarrow \mathfrak{S}_p^0$. Then the additional gluing conditions are as follows.

(F1) Let $\tilde{\Sigma} \in (G \wr \mathfrak{S}_p^0)^{q+1}$ with $\tilde{\Sigma} = (S_q, \dots, S_0)$ and $S_i = (\gamma_{i,p}, \dots, \gamma_{i,0}; \sigma_i)$ for $0 \leq i \leq q$. Then S_i acts on $\{0, \dots, p\} \times G$ by $S_i \cdot (j, \xi) = (\sigma_i(j), \gamma_{i,j} \xi)$ so that $\Pi(S_i)$ satisfy (S1)-(S4) for $0 \leq i \leq q$.

(F2) For all $0 \leq j \leq p$ we have $S_0 \cdot (j, \xi) = (j+1, \xi)$.

(F3) For all $0 \leq i \leq q$ we have $S_i \cdot (p, \xi) = (0, \xi)$.

(F4) For all $1 \leq i \leq q$ over each cycle of length l of τ_i from its disjoint cycle decomposition lie only orbits of length l of $T_i = S_i \circ S_{i-1}^{-1}$ with respect

to Π .

Given a trivial bundle over a PSD, Figure 2.5 visualizes the construction of a flat G -bundle over a Riemann surface from given gluing functions.

Remark 2.2.10.

- (1) Condition (F2) is equivalent to $\gamma_{0,j} = e$ for all $0 \leq j \leq p$. Here $e \in G$ denotes the identity element of G .
- (2) Condition (F3) is equivalent to $\gamma_{i,p} = e$ for all $0 \leq i \leq q$.
- (3) According to the theorem of Ambrose–Singer the holonomy group of a flat G -bundle over a compact manifold is discrete if G is a Lie group (see 9.2 of [36]). Since each principal G -bundle can be reduced to its holonomy bundle we may apply methods from combinatorial topology. Although this statement is mathematically not precise it suggests why a generalization of the Hilbert uniformization to flat G -bundles in contrast to general fiber bundles is feasible.

Remark 2.2.11. By definition of T_i for $1 \leq i \leq q$ we have $S_q = T_q \dots T_1 S_0$. Condition (F2) implies that there exist only orbits of length $wl(\sigma_0)$ of S_0 . It follows from (F4) that over each disjoint cycle of σ_q of length l lie only orbits of length l of S_q with respect to Π . We denote this property of S_q by (FC).

Notation. All gluing conditions, that is, (NZ1)-(NZ2) or (NZI1)-(NZI2), (S1)-(S4) and (F1)-(F4) are denoted by (*Hilb*).

Proposition 2.2.12. *Let (E, π, X, A) be a flat pointed G -bundle where X is a Riemann surface of genus $g \geq 0$ with $m \geq 0$ punctures P_1, \dots, P_m and a dipole (Q, χ) chosen as the base point. Moreover, let $p_0 \in E_Q$ be the base point of the total space, $u : X \rightarrow \overline{\mathbb{R}}$ a potential function with gradient vector field ξ and let $\mathcal{K}^* = \pi^{-1}(\mathcal{K})$ for the critical graph \mathcal{K} of ξ . Then there exists*

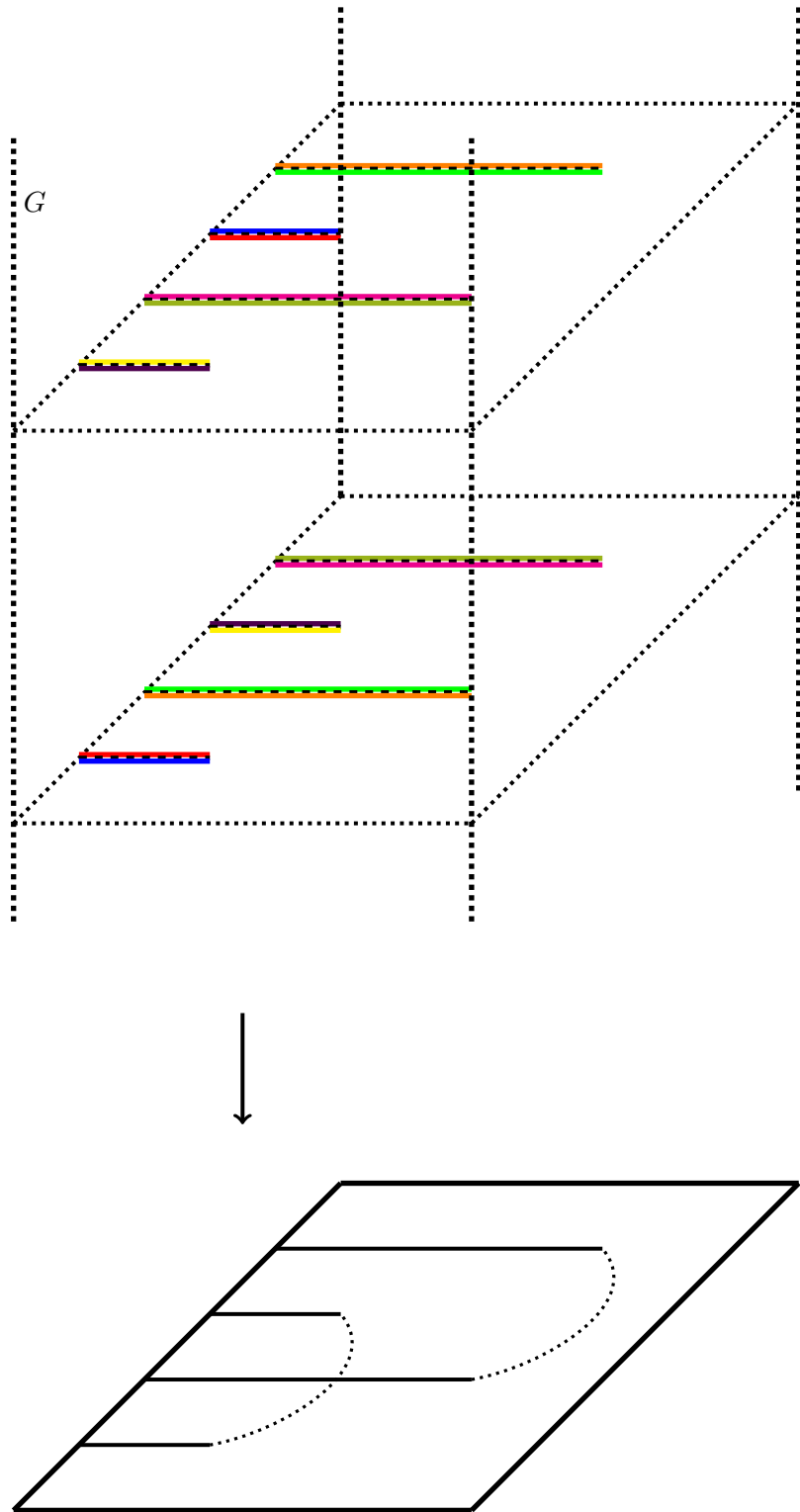

Figure 2.5: Gluing rules of the trivial bundle over a PSD

$\tilde{\Sigma} = (S_q : \dots : S_0)$ with $S_i \in G \wr \mathfrak{S}_p^0$ for $0 \leq i \leq q$ which satisfies (Hilb) such that the quotient $Y \times G / \approx$ is diffeomorphic to E . Here we denote by Y the extended PSD of X while \approx is the identification with respect to $\tilde{\Sigma}$.

Proof. By Theorem 2.2.9 we may assume that all axioms except possibly (F1)-(F4) are satisfied. Let (E, π, X, A) be a flat pointed principal G -bundle as in the assumption. Then there exists a unique $\Sigma = (\sigma_q : \dots : \sigma_0)$ with $\sigma_i \in \mathfrak{S}_p^0$ for $0 \leq i \leq q$ such that $Y / \sim = X$ with respect to Σ by 2.2.9. Since $X - \mathcal{K}$ is simply connected the complement $E - \mathcal{K}^*$ is homeomorphic to $(X - \mathcal{K}) \times G$ and the bundle $\pi|_{E - \mathcal{K}^*}$ is trivial as a flat G -bundle (see Example 1.1.11). Therefore, it remains to show that there is a continuous map $Y \times G \rightarrow E$ such that the diagram

$$\begin{array}{ccc} Y \times G & \xrightarrow{pr_1} & Y \\ \approx \downarrow \text{dotted} & & \downarrow \sim \\ E & \xrightarrow{\pi} & X \end{array} \quad (2.1)$$

commutes. The horizontal arrows correspond to the bundle projections. The vertical arrows are the quotient maps with respect to \approx (left arrow) and \sim (right arrow). The dotted arrow will be constructed by gluing the blocks $R_{i,j} \times G$ of $Y \times G$ across \mathcal{K}^* .

More precisely, for the moment let us consider a space \hat{Y} which is constructed from Y in the following way. The upper side of $R_{0,j}$ is glued to the lower side of $R_{0,j+1}$ for all $0 \leq j \leq p-1$ and the left hand side of $R_{i,j}$ is glued to the right hand side of $R_{i+1,j}$ for all $0 \leq i \leq q$ and $0 \leq j \leq p$. As a consequence, \hat{Y} is simply connected and there exists a continuous map $\hat{h} : \hat{Y} \rightarrow X$ which is defined by identifying the remaining upper and lower sides of the rectangles as described above for \sim . Namely, we glue the upper side of $R_{i,j}$ to the lower side of $R_{i,\sigma_i(j)}$ for $0 \leq i \leq q$ and $0 \leq j \leq p$ and one point is added at infinity.

The technical advantage of working with \hat{Y} instead of Y is that \hat{Y} is simply connected while Y is disconnected. We consider the pullback diagram

$$\begin{array}{ccc} \pi^*\hat{Y} & \longrightarrow & \hat{Y} \\ \hat{H} \downarrow & & \downarrow \hat{h} \\ E & \xrightarrow{\pi} & X \end{array} \quad (2.2)$$

where we denote the continuous map $\pi^*\hat{Y} \rightarrow E$ by \hat{H} .

Recall that there is a complex atlas $\{W_\alpha, \phi_\alpha\}$ of X which was constructed by means of the Hilbert uniformization (see Figure 2.3 as a reminder). We choose a pointed atlas $\{W_\alpha, \psi_\alpha\}$ of the flat bundle $\pi : E \rightarrow X$, that is, if (W_β, ψ_β) is a chart containing the dipole point $Q \in X$ then $\psi_\beta(p_0) = (Q, e)$. Here $e \in G$ is the identity of the Lie group. Since the bundle connection is flat we may assume the transition functions to be locally constant (see (3) of Definition 1.1.14). As \hat{Y} is simply connected we obtain a pointed homeomorphism $\hat{\Psi} : \hat{Y} \times G \rightarrow \pi^*\hat{Y}$. Consequently, by Diagram (2.2) there is a continuous map $\hat{Y} \times G \rightarrow E$ which is defined by gluing the blocks $R_{i,j} \times G$ of $\hat{Y} \times G$ in the following way. To obtain X from \hat{Y} we glue the upper side of each rectangle $R_{i,j}$ to the lower side of $R_{i,\sigma_i(j)}$ for $0 \leq i \leq q$ and $0 \leq j \leq p$. By construction of the atlas $\{W_\alpha, \phi_\alpha\}$, for each pair (i, j) there is an element $\gamma_{i,j} \in G$ given by the constant value of the respective transition function to the atlas $\{W_\alpha, \psi_\alpha\}$. It describes the parallel displacement from $R_{i,j}$ to $R_{i,\sigma_i(j)}$. More precisely, the gluing functions of the fiber G are determined by the action of the structure group. As the structure group can be reduced to the holonomy group of the bundle the gluing functions must be determined by the holonomy. Then the element $\gamma_{i,j}$ describes the parallel displacement of a continuous path segment from $R_{i,j}$ to $R_{i,\sigma_i(j)}$. Thus, the $\gamma_{i,j}$ are uniquely determined by the passage from $R_{i,j}$ to $R_{i,\sigma_i(j)}$ and we

have to identify the upper side of $R_{i,j}^\xi$ with the lower side of $R_{i,\sigma_i(j)}^{\gamma_{i,j}\xi}$. As a consequence, we assign the element $\gamma_{i,j} \in G$ to the upper side of $R_{i,j}$.

Next we need to show that the gluing functions S_i are elements of the wreath product $G \wr \mathfrak{S}_p^0$ for $0 \leq i \leq q$. The group G acts on itself by left multiplication and at the same time every element of Σ acts on $\{0, \dots, p\}$. These two actions define an action of $G^{p+1} \times \mathfrak{S}_p^0$ on $\{0, \dots, p\} \times G$ which has to satisfy the following property. Each element of Σ has to preserve the fiber G and the action of each element of G has to preserve the labeling $\{0, \dots, p\}$ of the grid of Y columnwise since this grid induces the atlas $\{W_\alpha, \phi_\alpha\}$ of X . This claim has to be made as π is locally trivial and G -equivariant. Consequently, the gluing function is an element of the wreath product $G \wr \mathfrak{S}_p^0$ for each column of the extended PSD. The identification \approx is therefore given by an element of $(G \wr \mathfrak{S}_p^0)^{q+1}$ and (F1) follows.

Let $\hat{Y}^0 \subseteq \hat{Y}$ be the subset defined by coordinates whose real part is larger than the maximum of the real parts of all slit end points. Then \hat{Y}^0 is a contractible domain in \mathbb{C} (see Figure 2.1). So the parallel transport restricted to \hat{Y}^0 is trivial (see (2) of Definition 1.1.14). Consequently, $\gamma_{0,j} = e$ for all $0 \leq j \leq p$, so that (F2) follows by (1) of Remark 2.2.10.

Let V_Q be a small, open, simply connected neighborhood of the dipole such that there exists β with $V_Q \subseteq W_\beta$. By construction of W_β there are neither critical points of u nor punctures in V_Q . Let $\zeta_Q = (0, n_1, \dots, n_s, p)$ be the cycle of σ_q from its disjoint cycle decomposition containing the numbers 0 and p . Then the rectangles $R_{q,0}, R_{q,n_1}, \dots, R_{q,n_s}, R_{q,p}, R_{i,p}, R_{i,0}$ for $0 \leq i \leq q$ and $R_{0,j}$ for $0 \leq j \leq p$ have nonempty intersection with V_Q (see Figure 2.3). It follows from (S1) that $S_i.(p, \xi) = (0, \gamma_{i,p}\xi)$ for all $0 \leq i \leq q$. Let us consider the base point of the bundle p_0 . The chart (W_β, ψ_β) containing Q satisfies $\psi_\beta(p_0) = (Q, e)$. Thus, the transition functions at Q are uniquely

defined by $g_{\alpha,\beta} = e$. Consequently, $\gamma_{i,p} = e$ for all $0 \leq i \leq q$ and so (F3) is satisfied.

Each disjoint cycle of τ_i represents a critical point of u for every $1 \leq i \leq q$ because the end points of the slits numbered by the entries of each disjoint cycle of some τ_i are identified to one critical point. The word length norm of each disjoint cycle of some τ_i is equal to the Morse index of the critical point. If there exists an orbit $\tilde{\zeta}$ of T_i whose length is greater than of the corresponding cycle $\Pi(\tilde{\zeta})$ of τ_i then the bundle projection is not locally trivial. To see this, let V be a small, open, simply connected neighborhood of a critical point R so that no further critical points, punctures or the dipole are in V . Let ζ be a cycle from the disjoint cycle decomposition of some τ_i representing R . The complement $V - \hat{\mathcal{K}}$ consists of $4 \text{wl}(\zeta)$ connected components. In other words, V intersects a finite number of rectangles given by the grid of Y (see Figure 2.4 for a visualization). On the other hand, $\pi^{-1}(V - \hat{\mathcal{K}})$ intersects a greater number of rectangles $R_{i,j}^\xi$ for $(j, \xi) \in \tilde{\zeta}$ where $\tilde{\zeta}$ is an orbit of T_i such that $\Pi(\tilde{\zeta}) = \zeta$. The exact number is determined by the length of $\tilde{\zeta}$. As V is simply connected but π is not injective in V it follows that π cannot be locally trivial. Note that by definition of the wreath product there is no orbit of smaller length of T_i over a cycle of τ_i with respect to Π .

□

In the next proposition we show that the inverse of 2.2.12 is satisfied.

Proposition 2.2.13. *Let $(a_i, b_j)_{i,j}$ be barycentric coordinates for $0 \leq i \leq q$, $0 \leq j \leq p$ and $(\gamma_{i,j}, \sigma_i)_{i,j} \in (G \wr \mathfrak{S}_p^0)^{q+1}$ so that $Z = ((a_i, b_j)_{i,j}, \Sigma)$ with $\Sigma = (\sigma_q : \dots : \sigma_0)$ is an element of $\text{Par}_{g,1}^m$. Assume that (Hilb) is satisfied for $(\gamma_{i,j}, \sigma_i)_{i,j}$. Let Y be the extended PSD with combinatorial type Z , $X = Y / \sim$ with respect to Σ and $E = Y \times G / \approx$ with respect to $\tilde{\Sigma} = (S_q : \dots : S_0)$ with*

$S_i = (\gamma_{i,j}; \sigma_i)$ for $0 \leq j \leq p$ and $0 \leq i \leq q$. Then the induced projection $\pi : E \rightarrow X$ is a flat pointed G -bundle with connection form A determined by $(\gamma_{i,j})_{i,j}$.

Proof. By Theorem 2.2.9 X is a Riemann surface which is homeomorphic to $S_{g,1}^{(m)}$. Thus, it remains to prove the assertion concerning the flat bundle structure. For this, we proceed in two steps. First a bundle atlas will be constructed such that the induced projection is smooth and locally trivial. Then we specify the parallel transport which determines the connection form A uniquely by Section 1.1.

Let $\{W_\alpha, \phi_\alpha\}$ be the complex atlas of X established by means of the Hilbert uniformization. We have explained in the beginning of this section how to construct charts $\{W_\alpha, \phi_\alpha\}$ (see Figure 2.3 as a reminder). We will use these open neighborhoods $\{W_\alpha\}$ to construct a smooth bundle atlas. Exemplarily, we will execute the construction for a point in the interior of a rectangle's edge. Let z' be a point on the upper side of a rectangle $R_{i,j}$ (as in Figure 2.3). As we have seen in the beginning of this section critical points, punctures and the dipole point have to be handled separately. There exists a semicircle H' around z' (see Figure 2.3) and a homeomorphism $\phi' : H' \hookrightarrow \mathbb{C}$. Let η' be the map $\phi' \times id : H' \times G \hookrightarrow \mathbb{C} \times G$. By definition of the identification \sim for Y there exists a point z'' in the interior of the lower edge of $R_{i,\sigma_i(j)}$ which is identified with z' to a point $x' \in X$. Moreover, there is a semicircle H'' around z'' of equal diameter as H' with a homeomorphism $\phi'' : H'' \hookrightarrow \mathbb{C}$ (see Figure 2.3). Let η'' be the map $\phi'' \times id : H'' \times G \hookrightarrow \mathbb{C} \times G$. Then by construction of $\{W_\alpha, \phi_\alpha\}$ we have that $\phi'(z') = 0 \in \mathbb{C}$ and points on the upper side of $R_{i,j}$ are mapped by ϕ' to \mathbb{R} . The analogous properties are satisfied for ϕ'' . We set $V' = \eta'(H' \times G)$ and $V'' = \eta''(H'' \times G)$. Moreover, let $\tilde{V}' = \{(x + \sqrt{-1}y, \xi) \in V' \mid y = 0\}$ and $\tilde{V}'' = \{(x + \sqrt{-1}y, \xi) \in V'' \mid y = 0\}$.

Then V' and V'' are reglued along \tilde{V}' and \tilde{V}'' to an open subset $W' \subseteq \mathbb{C} \times G$ the following way. The point $(\zeta, \xi) \in \tilde{V}'$ is identified with $(\zeta', \xi') \in \tilde{V}''$ if $\zeta = \zeta'$ and $\xi' = \gamma_{i,j}\xi$. We denote the quotient map $V' \sqcup V'' \rightarrow W'$ by f' . By construction of the sets $\{W_\alpha\}$ there exists a smooth diffeomorphism $\eta : W' \rightarrow W_\alpha \times G$ induced by $f' \circ (\eta' \sqcup \eta'')$ where W_α is a chart containing $x' \in X$. Consequently, pairs of the form (W_α, η) define smooth bundle charts for points in the interior of a rectangle's edge. The other cases work analogously using the explicit construction of the atlas $\{W_\alpha, \phi_\alpha\}$. We denote these smooth bundle charts by $\{W_\alpha, \psi_\alpha\}$. In particular, $\{W_\alpha, \psi_\alpha\}$ has locally constant transition functions as their values are given by $\gamma_{i,j} \in G$. To finish the first part of the proof, it remains to show that π is locally trivial with respect to $\{W_\alpha, \psi_\alpha\}$ so that the constructed charts establish a smooth bundle atlas for $\pi : E \rightarrow X$.

To this end, we need again to discuss several cases of points in Y . If $z \in Y$ is an interior point of a rectangle then there is a chart $W_\alpha \ni z$ which is the interior of a rectangle. Thus, $\pi^{-1}(W_\alpha) = W_\alpha \times G$ and π is locally trivial at every interior point of a rectangle. Let $z' \in Y$ be a point in the interior of some rectangle's edge and let $z'' \in Y$ be the corresponding point which is identified with z' to $x' \in X$ by \sim . If $z' \in Y_0$ there is a chart $W_{\alpha'} \ni x'$ with $\pi^{-1}(W_{\alpha'}) = W_{\alpha'} \times G$ by (F1) and (F2) since $\gamma_{0,j} = e$ for all $0 \leq j \leq p$. If $z' \in Y - Y_0$ then there is a chart $W_{\alpha'} \ni x'$ and a diffeomorphism $\psi_{\alpha'} : \pi^{-1}(W_{\alpha'}) \rightarrow W_{\alpha'} \times G$ as a consequence of the previous construction which we executed explicitly. Note that we applied (F1) to construct $(W_{\alpha'}, \phi_{\alpha'})$ using the Hilbert uniformization of Riemann surfaces. Let $\zeta = (t_1, \dots, t_r)$ be a cycle from the disjoint cycle decomposition of τ_i for some $1 \leq i \leq q$ and let $z_{t_j} \in Y$ be the rectangle vertices which are identified to a critical point $R \in X$ for $1 \leq j \leq r$. Then there is a chart (W_β, ψ_β)

with $R \in W_\beta$ that was constructed by gluing disk segments each of which is situated around each point z_{t_j} appropriately. Each disk segment lies within those rectangles having z_{t_j} as a vertex for $1 \leq j \leq r$ (see Figure 2.3 as a reminder). We need to show that π is injective and surjective in W_β . As was already noted in the proof of Proposition 2.2.12 there are exactly $4 \, wl(\zeta)$ rectangles having nonempty intersection with W_β so that $W_\beta - \hat{\mathcal{K}}$ consists of $4 \, wl(\zeta)$ connected components. By (F4) there are only orbits of T_i of length $wl(\zeta)$ which lie over ζ with respect to Π . Let $\tilde{\zeta}$ be an orbit of T_i such that $\Pi(\tilde{\zeta}) = \zeta$. Then there are exactly $4 \, wl(\zeta)$ rectangles $R_{i,j}^\xi$ having nonempty intersection with $\pi^{-1}(W_\beta)$ for $(j, \xi) \in \tilde{\zeta}$. As the restriction of π to each rectangle is injective it follows from the construction of W_β that $\pi|_{\pi^{-1}(W_\beta)}$ is injective. On the other hand, there is no orbit $\tilde{\zeta}$ of T_i whose length is smaller than of the cycle $\Pi(\tilde{\zeta})$ of τ_i by (F1). Thus, by the analogous argument π is surjective in W_β and its local triviality around each critical point follows.

To show local triviality of π around the dipole point we consider the cycle $\zeta_Q = (0, n_1, \dots, n_s, p)$ from the disjoint cycle decomposition of σ_q . Let (W_β, ψ_β) be the chart containing Q . Then $R_{q,0}, R_{q,n_k}, R_{q,p}, R_{i,p}, R_{i,0}, R_{0,j}$ for $1 \leq k \leq s, 0 \leq i \leq q$ and $0 \leq j \leq p$ are the only rectangles having nonempty intersection with W_β (see Figure 2.3). Every orbit $\tilde{\zeta}_Q$ of S_q with $\Pi(\tilde{\zeta}_Q) = \zeta_Q$ is of length $wl(\zeta_Q)$ by (FC). Moreover, by (F2) and (F3) we have $\gamma_{i,p} = e$ and $\gamma_{0,j} = e$. Consequently, for each such orbit $\tilde{\zeta}_Q$ there are exactly $wl(\zeta_Q) + 2q + p - 1$ rectangles $R_{i,j}^\xi$ intersecting $\pi^{-1}(W_\beta)$ nontrivially. This implies that π is injective in W_β applying the analogous argumentation as for critical points. On the other hand, by a similar argument as for critical points π is surjective in W_β since there is no orbit $\tilde{\zeta}_Q$ with $\Pi(\tilde{\zeta}_Q) = \zeta_Q$ and whose length is smaller than $wl(\zeta_Q)$ by (F1). So its local triviality around the dipole point follows.

It remains to check that π is locally trivial around the punctures. Each puncture is contained in a unique chart (W_γ, ψ_γ) . Moreover, there exists a cycle $\zeta = (m_1, \dots, m_t)$ from the disjoint cycle decomposition of σ_q such that $R_{q,m_1}, \dots, R_{q,m_t}$ are the only rectangles having nonempty intersection with W_γ . By (FC) every orbit $\tilde{\zeta}$ of S_q with $\Pi(\tilde{\zeta}) = \zeta$ is of length $wl(\zeta)$. Thus, we may apply the same argumentation as for the dipole point or the critical points to show that π is injective and surjective around each puncture. As a consequence, the local triviality of π follows.

We have verified that $\{W_\alpha, \psi_\alpha\}$ establishes a smooth bundle atlas for $\pi : E \rightarrow X$. Let (W_β, ψ_β) be the chart containing $Q \in X$. Then we choose the point $p_0 \in E_Q$ as the base point of the bundle so that $\psi_\beta(p_0) = (Q, e)$ is satisfied. As a consequence, the bundle is pointed.

In the second part of the proof we will specify the flat structure of the bundle. In fact, it is evident that the transition functions of $\{W_\alpha, \psi_\alpha\}$ are locally constant and their values are equal to the elements $\gamma_{i,j} \in G$. To make the flat connection form A more precise we will construct the parallel transport of the bundle. Then A is uniquely determined by Theorem 3.11 of [6]. After having constructed the parallel transport we will show that it depends only on the homotopy class of a path so that A is flat.

Let $\omega : I \rightarrow X$ be a continuous path with end points $\omega(0) = x_0$ and $\omega(1) = x_1$. Then there are only finitely many rectangles $R_{i_1,j_1}, \dots, R_{i_l,j_l}$ which are intersected by ω . We choose the numbering of the rectangles in the order how ω passes them. For simplification, we set R_λ for R_{i_λ,j_λ} , \overline{O}_λ for the upper side of R_λ and \underline{O}_λ for the lower side of R_λ where $1 \leq \lambda \leq l$. Any such path ω is homotopy equivalent to a piecewise continuous path $|\omega|$ which is defined as follows. The starting point $|\omega|(0)$ is the middle point of R_1 and the end point $|\omega|(1)$ is the middle point of R_l . Moreover, $|\omega|$ consists

only of path segments which are either parallel to the x -axis or to the y -axis. Further, $|\omega|$ is minimal in the sense that the number of its horizontal and vertical path segments within a rectangle should be minimal. In fact, $|\omega|$ can be considered a simplicial approximation of ω with respect to the rectangles. Note that $|\omega|$ may intersect more rectangles than ω and it is not unique. Two simplicial approximations of the same path are clearly homotopy equivalent. Let R'_1, \dots, R'_k be the rectangles which are cut by a simplicial approximation $|\omega|$ of ω and let $\overline{O}'_\kappa, \underline{O}'_\kappa$ be the upper and lower sides of R'_κ for $1 \leq \kappa \leq k$, respectively. Again we choose the numbering of the rectangles in the order how $|\omega|$ passes them.

In the next step we will calculate the parallel transport $P_{|\omega|}$. Afterwards we will show that $P_{|\omega|_1} = P_{|\omega|_2}$ for two simplicial approximations $|\omega|_1$ and $|\omega|_2$ of ω . It follows from the construction of the bundle atlas that $P_\omega = P_{|\omega|}$. As a consequence, the parallel transport depends only on the homotopy class of a path. Let us consider ω with some $|\omega|$ as introduced previously. If \overline{O}'_1 is identified with \underline{O}'_2 then the parallel displacement of the first path segment of $|\omega|$ equals γ_{i_1, j_1} . On the other hand, if \underline{O}'_1 is identified with \overline{O}'_2 then the parallel displacement of the first path segment of $|\omega|$ equals γ_{i_1, j_1}^{-1} . Inductively, we may deduce that there exist sequences $\gamma_\kappa = \gamma_{i_\kappa, j_\kappa}$ and $\epsilon_\kappa \in \{1, -1\}$ for $1 \leq \kappa \leq k$ such that $P_{|\omega|} = \gamma_k^{\epsilon_k} \dots \gamma_1^{\epsilon_1}$.

To finish the proof of the proposition it remains to show that this equation does not depend on the choice of a simplicial approximation for ω . To this end, we will distinguish the following path types of ω . As any path is the composition of these path types the proposition will follow.

- (1) Let $x_0, x_1 \in R_1$ and assume that ω does not intersect any edge of R_1 . Then ω is either homotopy equivalent to the middle point of R_1 or to a loop which does not cut any edge of R_1 . In the first case, $|\omega|$ is defined

as the middle point of R_1 . In the second case, $|\omega|$ bounds a rectangle inside the interior of R_1 . In both cases, the parallel transport is trivial (see Example 1.1.11) and depends only on the homotopy class of the path.

- (2) Let $x_0 \in R_1$, $x_1 \in R_2$ and assume that ω intersects R_1 and R_2 in the interior of a common edge. In particular, we assume that the intersection point is neither a corner of R_1 nor of R_2 . The path $|\omega|$ is a path segment from the middle point of R_1 to the middle point of R_2 which is either parallel to the x -axis or to the y -axis. If the common edge of R_1 and R_2 is vertical then the parallel transport $P_{|\omega|}$ is trivial. If the common edge is horizontal then $P_{|\omega|} = \gamma_1^\epsilon$ for some $\epsilon \in \{1, -1\}$. In both cases we have $P_\omega = P_{|\omega|}$.
- (3) Let $x_0 \in R_1$, $x_1 \in R_2$ and assume that ω intersects R_1 and R_2 in a common vertex which is not part of a critical point. Then there are two ways how to construct a simplicial approximation of ω . These paths $|\omega|_1$ and $|\omega|_2$ are depicted in Figure 2.6.

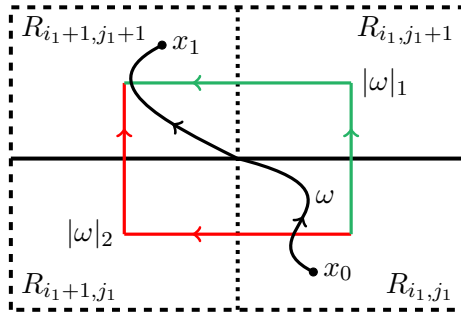

Figure 2.6: Path through a vertex

We apply the notation from Figure 2.6 in the ongoing argumentation. As the vertex point is not part of a critical point $(j_1 + 1)$ is a trivial cycle of τ_{i_1+1} . Consequently, we have that $\gamma_{i_1+1, j_1} \gamma_{i_1, j_1}^{-1} = e$ by (F4).

It follows for the parallel displacement $P_{|\omega|_1} = \gamma_{i_1, j_1} = \gamma_{i_1+1, j_1} = P_{|\omega|_2}$. Thus, the parallel transport P_ω does not depend on the choice of the simplicial approximation for ω .

- (4) Let $x_0 \in R_1$, $x_1 \in R_2$ and assume that ω intersects R_1 and R_2 in a common vertex which is part of a nondegenerate critical point. The argumentation for critical points of higher Morse index works analogously and will be mentioned shortly in the end. There are two ways how to construct simplicial approximations $|\omega|_1$ and $|\omega|_2$ for ω (see Figure 2.7).

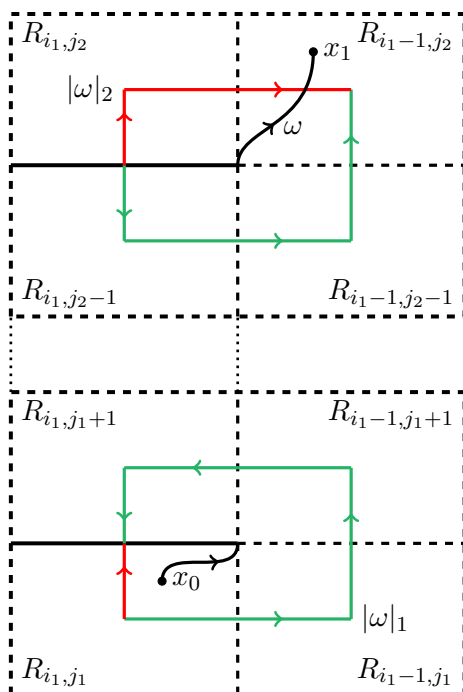

Figure 2.7: Path through a critical point

We apply the notation from Figure 2.7 in the ongoing argumentation. By (F2) and (F4) we have $\gamma_{i, j_1} = e$ and $\gamma_{i, j_2-1} = e$ for all $i < i_1$ since either these values equal $\gamma_{0, j}$ for $j \in \{j_1, j_2 - 1\}$ or $(j_1 + 1)$ and (j_2) are trivial cycles of τ_i for all $i < i_1$. The second claim holds as

$\sigma_i(j_1) = j_1 + 1$ and $\sigma_i(j_2 - 1) = j_2$ for all $i < i_1$. As we have seen in (2) the parallel displacement of all horizontal path segments of $|\omega|_1$ and $|\omega|_2$ is trivial. Consequently, $P_{|\omega|_1} = \gamma_{i_1, j_2-1}^{-1}$ and $P_{|\omega|_2} = \gamma_{i_1, j_1}$. By (F4) we have $\gamma_{i_1, j_1} \gamma_{i_1, j_2-1} = e$ because $(j_1 + 1, j_2)$ is a disjoint cycle of τ_{i_1} . It follows that $P_{|\omega|_1} = P_{|\omega|_2}$.

For critical points of higher Morse index the considerations are analogous. We just have to consider disjoint cycles ζ of each τ_i whose length is greater than two. Then the simplicial approximations intersect $4 \text{wl}(\zeta)$ rectangles and we apply the formula for $P_{|\omega|}$ as calculated above.

- (5) It remains to consider the cases where the path ω goes through the dipole point or into a puncture. The idea of proof is in both cases very similar. So let ω be a continuous path in X as before for which we assume that it passes $Q \in X$. If ω is not a loop then it is sufficient to consider a composition of path segments as described in (2). Thus, it remains to discuss the case where ω is a loop through Q . Moreover, we may assume that ω neither intersects a vertex point of a rectangle as this case was discussed in (3) and (4) nor ω goes into a puncture (see below for the puncture case). Let $\zeta_Q = (0, n_1, \dots, n_s, p)$ be the cycle from the disjoint cycle decomposition of σ_q which contains 0 and p . We need to distinguish simplicial approximations $|\omega|_1$ and $|\omega|_2$ of ω as shown in Figure 2.8.

On the one hand, $|\omega|_1$ intersects all rectangles R_{q, n_j} for $1 \leq j \leq s$. On the other hand, $|\omega|_2$ intersects none of these rectangles. Then $P_{|\omega|_1} = \gamma_{q, p} \gamma_{q, n_s} \cdots \gamma_{q, n_1} \gamma_{q, 0} = e$ by (FC) and $P_{|\omega|_2} = e$ by (F2). It is clear that $P_{|\omega|} = e$ for every simplicial approximation $|\omega|$. As a consequence, P_ω depends only on the homotopy class of ω .

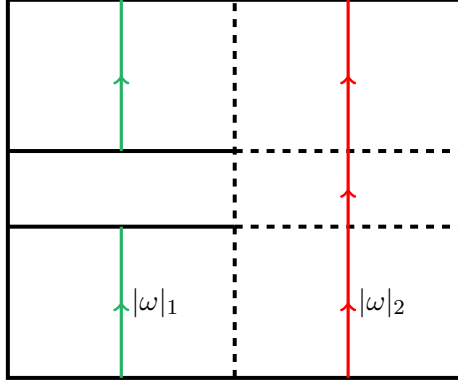

Figure 2.8: Path through the dipole point

The argumentation for punctures is analogous so that we abstain from all details. Let ω be a path in X that goes into a puncture $P \in \mathcal{P}$ but neither passes the dipole point nor a critical point of u . Moreover, we may assume as in the dipole case that ω is a closed path up to P . Let $\zeta = (m_1, \dots, m_r)$ be a cycle from the disjoint cycle decomposition of σ_q such that the rectangles $R_{q,m_1}, \dots, R_{q,m_r}$ have nonempty intersection with P . Then the path $|\omega|$ has to intersect all of these rectangles so that $P_{|\omega|} = \gamma_{q,m_r} \dots \gamma_{q,m_1}$. This equals to $e \in G$ by (FC). It is clear that for any path that is homotopic to $|\omega|$ the parallel transport is trivial.

Since an arbitrary continuous path ω in X is the composition of paths as described in (1)-(5) it follows that the parallel transport P_ω depends only on the homotopy class of ω .

□

Definition 2.2.14. Let $\mathfrak{H}_{g,1}^m(G)$ be the moduli space of flat, pointed G -bundles over Riemann surfaces of topological type $S_{g,1}^{(m)}$ with a potential function. It consists of equivalence classes of flat pointed G -bundles $(E, \pi, X, A, u, \mathcal{P}, \mathcal{Q}, p_0)$ where X is a Riemann surface of genus $g \geq 0$ with

$m \geq 0$ punctures $\mathcal{P} = \{P_1, \dots, P_m\}$ and a dipole point $\mathcal{Q} = (Q, \chi)$ fixed as a base point, and a potential function $u : X \rightarrow \overline{\mathbb{R}}$. Moreover, let $p_0 \in E_{\mathcal{Q}}$ be the base point of the bundle. Two flat pointed G -bundles with potential functions $(E, \pi, X, A, u, \mathcal{P}, \mathcal{Q}, p_0)$ and $(E', \pi', X', A', u', \mathcal{P}', \mathcal{Q}', p'_0)$ are equivalent if the following conditions are satisfied. There exists a conformal homeomorphism $\phi : X \rightarrow X'$ such that ϕ fixes the set of punctures, $\phi(Q) = Q'$, $d\phi(\chi) = \chi'$ and $u' \circ \phi = u$. Moreover, there is a fiber preserving diffeomorphism $f : E \rightarrow E'$ such that $\pi' \circ f = \phi \circ \pi$, $f(p_0) = p'_0$ and $f_*A = A'$. We call $\mathfrak{H}_{g,1}^m(G)$ the *moduli space of flat G -bundles over Riemann surfaces with potential function*. A point in $\mathfrak{H}_{g,1}^m(G)$ is denoted by $[E, \pi, X, A, u, \mathcal{P}, \mathcal{Q}, p_0]$ which we usually abbreviate as $[E, \pi, X, A, u]$.

In view of Lemma 1.2.8, the moduli space $\mathfrak{H}_{g,1}^m(G)$ can be identified with the product of the space of potential functions $\text{Pot}_{g,1}^m$ on $S_{g,1}^{(m)}$, $\mathcal{S}(S_{g,1}^{(m)})$ and $\mathcal{R}_G(S_{g,1}^{(m)})$ divided by the action of the diffeomorphism group, that is, $\text{Pot}_{g,1}^m \times \mathcal{S}(S_{g,1}^{(m)}) \times \mathcal{R}_G(S_{g,1}^{(m)}) / \text{Diff}_{g,1}^m$. We shall make use of the topology of $\text{Pot}_{g,1}^m$ which was introduced in [23] without further comments. Moreover, note that the forgetful map $\mathfrak{H}_{g,1}^m(G) \rightarrow \mathcal{M}_{g,1}^{(m)}(G)$ is continuous. Since we have previously seen that $\mathfrak{H}_{g,1}^m(G)$ can be represented as a fiber product the following assertion is a consequence of Lemmas 1.2.8 and 2.2.2. In particular, $\mathfrak{H}_{g,1}^m(G)$ and $\mathcal{M}_{g,1}^{(m)}(G)$ are homotopy equivalent.

Lemma 2.2.15. *The following square is a commutative diagram of four fiber bundles. The fiber of the horizontal projections is the representation variety $\mathcal{R}_G(S_{g,1}^{(m)})$. The vertical maps are affine bundles of dimension $m + 1$.*

$$\begin{array}{ccc}
\mathfrak{H}_{g,1}^m(G) & \longrightarrow & \mathfrak{H}_{g,1}^m \\
\mathfrak{p}(G) \downarrow & & \downarrow \mathfrak{p} \\
\mathcal{M}_{g,1}^{(m)}(G) & \xrightarrow{\Phi(G)} & \mathcal{M}_{g,1}^{(m)}
\end{array}$$

Definition 2.2.16. Let $\mathbb{P}_{p,q}(G)$ be the space of all elements from the Lie group $(G \wr \mathfrak{S}_p^0)^{q+1}$ which satisfy (NZ1) and (NZ2). We denote $\coprod_{p,q} \mathbb{P}_{p,q}(G)$ by $\mathbb{P}(G)$ for $0 \leq p \leq 2h$ and $0 \leq q \leq h$ where $h = 2g + m$. There are face and degeneracy maps of $\mathbb{P}(G)$ as follows. Let $S \in G \wr \mathfrak{S}_p^0$, that is, $S = (\gamma_p, \dots, \gamma_0; \sigma)$ and let

$$D_j''(S) = \begin{cases} (\gamma_p, \dots, \gamma_{\sigma^{-1}(j)}\gamma_j, \dots, \widehat{\gamma_{\sigma^{-1}(j)}}, \dots, \gamma_0; D_j(\sigma)), & \text{if } j \geq \sigma^{-1}(j) \\ (\gamma_p, \dots, \widehat{\gamma_{\sigma^{-1}(j)}}, \dots, \gamma_{\sigma^{-1}(j)}\gamma_j, \dots, \gamma_0; D_j(\sigma)), & \text{if } j \leq \sigma^{-1}(j). \end{cases}$$

The maps D_j'' satisfy the simplicial identities.² The horizontal face maps $d'_i : \mathbb{P}_{p,q}(G) \rightarrow \mathbb{P}_{p,q-1}(G)$ are given by

$$d'_i(S_q, \dots, S_0) = (S_q, \dots, \widehat{S}_i, \dots, S_0),$$

for $0 \leq i \leq q$ and the vertical face maps $d''_j : \mathbb{P}_{p,q}(G) \rightarrow \mathbb{P}_{p-1,q}(G)$ are

$$d''_j(S_q, \dots, S_0) = (D_j''(S_q), \dots, D_j''(S_0))$$

for $0 \leq j \leq q$. All face and degeneracy maps are continuous with respect to the topology of G so that $(\mathbb{P}_{p,q}(G), d'_i, d''_j)_{p,q,i,j}$ defines a bisimplicial space. Its geometric realization is denoted by $\text{Par}_{g,1}^m(G)$. Note that by definition of the geometric realization the topology of G is taken here into account (see for instance Section 14 of [41]). Moreover, let $\text{Par}_{g,1}^m(G)$ consist of those cells which do not satisfy (Hilb) and let $\mathfrak{P}_{g,1}^m(G)$ be the complement of $\text{Par}_{g,1}^m(G)$ in $\text{Par}_{g,1}^m(G)$. We call $\mathfrak{P}_{g,1}^m(G)$ the *nondegenerated* part of $\text{Par}_{g,1}^m(G)$.

Let G be a finite group which we think of as a subgroup of a symmetric

²The j -th degeneracy map is defined by introducing j as a fixpoint of each permutation from \mathfrak{S}_{p-1}^0 and then setting e on the j -th entry of the $(p-1)$ -tuple of elements from G .

group \mathfrak{S}_K for some sufficiently large $K \in \mathbb{N}$. We define $\mathbb{P}_{p,q}(G)$ as the free abelian group generated by all elements from $(G \wr \mathfrak{S}_p^0)^{q+1}$ which satisfy (NZ1) and (NZ2). We set $\mathbb{P}(G) = \bigoplus_{p,q} \mathbb{P}_{p,q}(G)$ for $0 \leq p \leq 2h$ and $0 \leq q \leq h$ where $h = 2g + m$.

If G equals the full symmetric group \mathfrak{S}_K we denote $\mathbb{P}_{p,q}(G)$ by $\mathbb{P}_{p,q}[K]$ and $\mathbb{P}(G)$ by $\mathbb{P}[K]$. Now $\mathbb{P}[K]$ establishes a chain complex when equipped with the boundary operator $d = d' + (-1)^q d''$ which is defined as follows. We have $d' = \sum_{i=0}^q (-1)^i d'_i$ and $d'' = \sum_{j=0}^p (-1)^j d''_j$. The geometric realization of the bisimplicial space $(\mathbb{P}_{p,q}[K], d'_i, d''_j)_{p,q,i,j}$ is denoted by $\text{Par}_{g,1}^m[K]$. Moreover, let $\mathbb{P}'[K]$ consist of those elements which do not satisfy (Hilb) and let $\text{Par}'_{g,1}{}^m[K]$ be the appropriate subspace of $\text{Par}_{g,1}^m[K]$. We denote by $\mathfrak{P}_{g,1}^m[K]$ the complement of $\text{Par}'_{g,1}{}^m[K]$ in $\text{Par}_{g,1}^m[K]$. It is called the *nondegenerated* part of $\text{Par}_{g,1}^m[K]$.

Note that $\text{Par}_{g,1}^m[K]$ equals $\text{Par}_{g,1}^m(\mathfrak{S}_K)$ so that both definitions of 2.2.16 agree for symmetric groups. Since $\text{Par}_{g,1}^m(G)$ is the geometric realization of a bisimplicial space its topology is defined (see Section 14 of [41]). The face maps d'_i and d''_j commute with the canonical projection to $\text{Par}_{g,1}^m$ (see Definition 2.2.7). More precisely, for the projections $\Pi_{p,q} : \mathbb{P}_{p,q}(G) \rightarrow \mathbb{P}_{p,q}$ we have $\Pi_{p,q} \circ d'_i = \partial'_i \circ \Pi_{p,q}$ and $\Pi_{p,q} \circ d''_j = \partial''_j \circ \Pi_{p,q}$.

For the Hilbert uniformization of flat G -bundles over Riemann surfaces we will focus on $\mathfrak{P}_{g,1}^m(G)$ for which the central assertion of Theorem 2.2.19 is satisfied.

Remark 2.2.17. The construction of Proposition 2.2.12 leads to a map

$$\begin{aligned} \mathcal{H}(G) : \mathfrak{H}_{g,1}^m(G) &\rightarrow \mathfrak{P}_{g,1}^m(G), \\ \mathcal{H}(G)([E, \pi, X, A, u]) &= ((a_i, b_j)_{i,j}, \tilde{\Sigma}) \end{aligned}$$

where $(a_i, b_j)_{i,j}$ are barycentric coordinates and $\tilde{\Sigma} = (S_q : \dots : S_0)$ with

$S_i = (\gamma_{i,j}; \sigma_i) \in G \wr \mathfrak{S}_p^0$. We call $\mathcal{H}(G)$ the *Hilbert uniformization of flat G -bundles*.

Proof. As this was already proven in 2.2.12 we just repeat the most important ideas briefly. Let $[E, \pi, X, A, u]$ be an equivalence class from $\mathfrak{H}_{g,1}^m(G)$ so that $X - \mathcal{K}$ is a PSD which defines uniquely a PSM with barycentric coordinates $(a_i, b_j)_{i,j} \in \Delta^q \times \Delta^p$. By means of the decomposition, we obtain gluing permutations $(\sigma_i)_i \in (\mathfrak{S}_p^0)^{q+1}$ for the extended PSD to $X - \mathcal{K}$. Since the connection A is flat it determines a parallel transport depending only on the homotopy class of a path and locally constant transition functions, thus elements $\gamma_{i,j} \in G$ with $S_i \in (G \wr \mathfrak{S}_p^0)^{q+1}$. Then by 2.2.12 $((a_i, b_j)_{i,j}, \tilde{\Sigma})$ satisfies *(Hilb)*. All construction details can be found in 2.2.12.

□

Remark 2.2.18. The construction of Proposition 2.2.13 leads to a map

$$\begin{aligned} \mathcal{G}(G) : \mathfrak{P}_{g,1}^m(G) &\rightarrow \mathfrak{H}_{g,1}^m(G), \\ \mathcal{G}(G)((a_i, b_j)_{i,j}, \tilde{\Sigma}) &= [E, \pi, X, A, u] \end{aligned}$$

where $(a_i, b_j)_{i,j}$ are barycentric coordinates and $\tilde{\Sigma} = (S_q : \dots : S_0)$ with $S_i = (\gamma_{i,j}; \sigma_i) \in G \wr \mathfrak{S}_p^0$. We call $\mathcal{G}(G)$ the *inverse of the Hilbert uniformization of flat G -bundles*.

Proof. As this was already proven in 2.2.13 we just repeat the most important ideas briefly. Let $((a_i, b_j)_{i,j}, \tilde{\Sigma})$ be a point in $\mathfrak{P}_{g,1}^m(G)$. Then there exists a unique PSM with barycentric coordinates $(a_i, b_j)_{i,j}$ and gluing data Σ such that gluing the corresponding extended PSD Y by \sim leads to a Riemann surface X with potential function u . The identification of $Y \times G$ by \approx with respect to $\tilde{\Sigma}$ determines a pointed principal G -bundle $\pi : E \rightarrow X$. Moreover, $(\gamma_{i,j})_{i,j}$ defines a unique parallel transport which depends only on

the homotopy class of a path and induces a flat connection form A . This is shown in detail in Proposition 2.2.13.

□

In the next theorem we will verify that the maps $\mathcal{H}(G)$ and $\mathcal{G}(G)$ are inverses as indicated by their namings. We will show that both maps are continuous in Section 2.3. A consequence is that the Hilbert uniformization is a homeomorphism.

Theorem 2.2.19. *The maps $\mathcal{H}(G)$ and $\mathcal{G}(G)$ are inverses.*

Proof. In Chapter 5 of [9] and later in Chapter 3 of [23] it was verified that $\mathcal{H} = \mathcal{H}(\langle e \rangle)$ and $\mathcal{G} = \mathcal{G}(\langle e \rangle)$ are inverses for the trivial group $G = \langle e \rangle$. We will now generalize this claim to arbitrary Lie groups G .

First we show that $\mathcal{H}(G) \circ \mathcal{G}(G)$ is the identity. Let $((a_i, b_j)_{i,j}, \tilde{\Sigma}) \in \mathfrak{P}_{g,1}^m(G)$ then $\mathcal{H}(G) \circ \mathcal{G}(G)((a_i, b_j)_{i,j}, \tilde{\Sigma}) = \mathcal{H}(G)([E, \pi, X, A, u])$. The parallel transport P^A to A is representable solely by means of the elements $\gamma_{i,j} \in G$ as we have seen in Proposition 2.2.13. In fact, these $\gamma_{i,j} \in G$ define locally constant transition functions of the flat G -bundle structure (see Proposition 2.2.13). Since $\mathcal{H}([X, u]) = ((a_i, b_j)_{i,j}, \Sigma)$ and the locally constant transition functions $\gamma_{i,j} \in G$ define gluing maps for the fiber by Proposition 2.2.12 it follows that $\mathcal{H}(G)([E, \pi, X, A, u]) = ((a_i, b_j)_{i,j}, \tilde{\Sigma})$. As a consequence, $\mathcal{H}(G) \circ \mathcal{G}(G) = id$. For the opposite direction let $[E, \pi, X, A, u] \in \mathfrak{H}_{g,1}^m(G)$ and let

$$\mathcal{G}(G) \circ \mathcal{H}(G)([E, \pi, X, A, u]) = \mathcal{G}(G)((a_i, b_j)_{i,j}, \tilde{\Sigma}) = [E', \pi', X', A', u'].$$

By Theorem 2.2.9 it follows that $[X, u] = [X', u']$ and there exists a conformal homeomorphism $f : X \rightarrow X'$. It remains to show on the one hand that E and E' are diffeomorphic and on the other hand that $\pi : E \rightarrow X$ and

$\pi' : E' \rightarrow X'$ are isomorphic flat G -bundles. From the combinatorial data $((a_i, b_j)_{i,j}, \tilde{\Sigma})$ we obtain the trivial bundle E'' over the PSD $X - \mathcal{K}$ by means of the Hilbert uniformization \mathcal{H} . As described in Proposition 2.2.12 we may construct the trivial bundle $\hat{E} \rightarrow \hat{Y}$ from E'' with an inclusion $\nu : E'' \rightarrow \hat{E}$. Moreover, we have seen in this proposition that we obtain a homeomorphism $h : E'' \rightarrow E - \mathcal{K}^*$. Hence, there are continuous maps $\psi' : E - \mathcal{K}^* \rightarrow E'$ and $\hat{\psi} : \hat{E} \rightarrow E'$ by definition of $\mathcal{G}(G)$ such that $\psi' \circ h = \hat{\psi} \circ \nu$. Let $\{V_\lambda, \chi_\lambda\}$ be a fixed atlas of the Lie group G and let $\{W'_\alpha, \psi'_\alpha\}$ be the bundle atlas of E' as constructed in Proposition 2.2.13. We set $W_\alpha = f^{-1}(W'_\alpha)$. There exists an extension of $\hat{\psi}$ onto each chart having nonempty intersection with an upper or lower edge of a rectangle. Thus, ψ' is extendable to \mathcal{K}^* . More precisely, for any $y \in \mathcal{K}^*$ there exists α with $\pi(y) \in W_\alpha$. We denote the atlas given by the Hilbert uniformization by $\{W_\alpha, \phi_\alpha\}$ as before. Then we define the desired extension $\psi : E \rightarrow E'$ for $y \in \mathcal{K}^*$ by $\pi'^{-1} \circ f \circ \pi(y)$. As a consequence, we obtain a diffeomorphism $\psi : E \rightarrow E'$ with respect to the charts $\{W_\alpha \times V_\lambda, \phi_\alpha \times \chi_\lambda\}$ for E and $\{W'_\alpha \times V_\lambda, (\phi_\alpha \circ f^{-1}) \times \chi_\lambda\}$ for E' . It remains to show that ψ is a flat bundle isomorphism, that is, the diagram

$$\begin{array}{ccc}
 E & \xrightarrow{\psi} & E' \\
 \pi \downarrow & & \downarrow \pi' \\
 X & \xrightarrow{f} & X'
 \end{array}$$

should commute and $\psi_* A = A'$. By construction of $\{W'_\alpha, \psi'_\alpha\}$ it follows that $\{W_\alpha, \psi'_\alpha \circ f\}$ defines a bundle atlas for $\pi : E \rightarrow X$. We write ψ_α for $\psi'_\alpha \circ f$. Since $\pi' \circ \psi \circ \pi^{-1}(W_\alpha) = W'_\alpha$ it follows that ψ is fiber preserving and in particular $f \circ \pi = \pi' \circ \psi$. As a consequence, ψ preserves the locally constant

transition functions. More precisely,

$$\begin{aligned} (f^{-1} \times id) \circ \psi'_\beta \circ \psi \circ \psi_\alpha^{-1}((W_\alpha \cap W_\beta) \times G) &= \psi_\beta \circ \psi_\alpha^{-1}((W_\alpha \cap W_\beta) \times G) \\ \psi'_\beta \circ \psi \circ \psi_\alpha^{-1} \circ (f^{-1} \times id)((W'_\alpha \cap W'_\beta) \times G) &= \psi'_\beta \circ \psi_\alpha'^{-1}((W'_\alpha \cap W'_\beta) \times G) \end{aligned}$$

on every nonempty intersection $W_\alpha \cap W_\beta$. Thus, $\psi'_\beta \circ \psi_\alpha'^{-1}(x') = (x', g_{\alpha,\beta})$ and $\psi_\beta \circ \psi_\alpha^{-1}(x) = (x, g_{\alpha,\beta})$ for every $x \in X$ and $x' = f(x)$. As a consequence, we have $\psi_* A = A'$ for the flat connection forms and finally $\mathcal{G}(G) \circ \mathcal{H}(G) = id$.

□

2.3 Topology of the Hilbert uniformization

In this section our main objective is to prove that the Hilbert uniformization $\mathcal{H}(G)$ as well as its inverse $\mathcal{G}(G)$ are continuous for all Lie groups G . To this end, we first introduce simplicial fiber bundles in order to show that the projection $P_{\mathfrak{P}} : \mathfrak{P}_{g,1}^m(G) \rightarrow \mathfrak{P}_{g,1}^m$ is a topological fiber bundle with fiber $\mathcal{R}_G(S_{g,1}^m)$. The continuity proofs for $\mathcal{H}(G)$ and $\mathcal{G}(G)$ will rely on this fact. An introduction to simplicial sets can be found in Section 1 of [41].

Notation. Let T be a topological space and let $S_*(T)$ be the simplicial set of singular simplices $\sigma : \Delta^n \rightarrow T$ with the standard simplicial maps. We denote by $\Delta[n] \subseteq S_*(\Delta^n)$ the subsimplicial set which is defined as follows. Let e_0, \dots, e_n be the vertices of Δ^n . Then the k -th face $\Delta[n]_k$ of $\Delta[n]$ consists of k -simplices $\sigma = \langle e_{i_0} \dots e_{i_k} \rangle$ for $0 \leq i_0 \leq \dots \leq i_k \leq n$. Here we denote by $\langle e_{i_0} \dots e_{i_k} \rangle$ the k -simplex spanned by e_{i_0}, \dots, e_{i_k} .

Note that for every simplicial set A and any simplex $\sigma \in A_n$ where $n \geq 0$ there exists a simplicial map $f_\sigma : \Delta[n] \rightarrow A$ with $f_\sigma(id_{\Delta^n}) = \sigma$ (see Section 5 of [41]).

Let $\psi : A \rightarrow B$ be a simplicial map of two simplicial sets and let $\sigma \in B$ be a

simplex. Then we may define the fiber product $A \times_B \Delta[n]$ as follows. It is the universal simplicial set which makes the following diagram commute.

$$\begin{array}{ccc} A \times_B \Delta[n] & \longrightarrow & \Delta[n] \\ \downarrow & & \downarrow f_\sigma \\ A & \xrightarrow{\psi} & B \end{array}$$

Definition 2.3.1. A simplicial map $\psi : A \rightarrow B$ of two simplicial sets is a *simplicial fiber bundle* with fiber C if for all $n \geq 0$ and all $\sigma \in B_n$ there exists a commutative diagram

$$\begin{array}{ccc} C \times \Delta[n] & \xrightarrow{\cong} & A \times_B \Delta[n] \\ \searrow p_1 & & \swarrow p_2 \\ & \Delta[n] & \end{array}$$

where p_1 and p_2 are the projections on the first and second factor, respectively. The horizontal map is an equivalence of simplicial sets. Note that the fiber C is a simplicial set.

Lemma 2.3.2. *Let $\psi : A \rightarrow B$ be a simplicial fiber bundle with fiber C . Then the geometric realization $|\psi| : |A| \rightarrow |B|$ is a topological fiber bundle with fiber $|C|$.*

Proof. By Section 17 of [41] we have $|A \times_B \Delta[n]| = |A| \times_{|B|} |\Delta[n]|$ for the geometric realizations. Thus, there is the pullback diagram

$$\begin{array}{ccc} |A \times_B \Delta[n]| & \longrightarrow & |\Delta[n]| \\ \downarrow & & \downarrow |f_\sigma| \\ |A| & \xrightarrow{|\psi|} & |B| \end{array}$$

of topological spaces. Moreover, for all $n \geq 0$ and simplices $\sigma \in B_n$

$$\begin{array}{ccc}
 |\Delta[n] \times C| & \xrightarrow{\cong} & |A \times_B \Delta[n]| \\
 \searrow |p_1| & & \swarrow |p_2| \\
 & |\Delta[n]| &
 \end{array}$$

is a commutative diagram of continuous maps. Consequently, by universality of the pullback, $|\psi|$ is a fiber bundle with fiber $|C|$ over each cell of $|B|$. Finally, it follows from Lemma 2.3.3 that $|\psi| : |A| \rightarrow |B|$ is a fiber bundle with fiber $|C|$.

□

Lemma 2.3.3. *Let $f : E \rightarrow B$ be a continuous map of CW-complexes and let $\chi_\alpha : e_\alpha^n \rightarrow B$ be the characteristic maps of B . Assume that for all $n \geq 0$ and all α the pullbacks $e_\alpha^n \times_B E \rightarrow e_\alpha^n$ are fiber bundles with fiber F . Then $f : E \rightarrow B$ is a fiber bundle with fiber F .*

□

Lemma 2.3.3 can be proven by an induction argument on the k -skeleton of B . We will omit the details.

Corollary 2.3.4. *The projection $P_{\mathfrak{P}}(G) : \mathfrak{P}_{g,1}^m(G) \rightarrow \mathfrak{P}_{g,1}^m$ is a fiber bundle with fiber $\mathcal{R}_G(S_{g,1}^{(m)})$.*

Proof. By definition, $\mathfrak{P}_{g,1}^m(G)$ and $\mathfrak{P}_{g,1}^m$ are open subsets of $\text{Par}_{g,1}^m(G)$ and $\text{Par}_{g,1}^m$, respectively. To apply Lemma 2.3.2 we set $A_n = \coprod_{p+q=n} \mathbb{P}_{p,q}(G)$ and $B_n = \coprod_{p+q=n} \mathbb{P}_{p,q}$. The forgetful maps $\psi_n : A_n \rightarrow B_n$ define a simplicial fiber bundle with fiber C given by $C_n = \coprod_{p+q=n} G^{(p+1)(q+1)}$. Hence, the forgetful map of the G -structure $\text{Par}_{g,1}^m(G) \rightarrow \text{Par}_{g,1}^m$ is a fiber bundle by Lemma 2.3.2. Let $\tilde{\mathfrak{P}} \subseteq \text{Par}_{g,1}^m(G)$ consist only of those elements which satisfy (F1)-(F4).

By the same argument, it follows that the forgetful map of the G -structure $\bar{P} : \bar{\mathfrak{P}} \rightarrow \text{Par}_{g,1}^m$ is a fiber bundle. The fiber is a subspace of $|C|$. Then by definition of the degenerated cells of $\text{Par}_{g,1}^m(G)$ and $\text{Par}_{g,1}^m$ we have $\bar{P}^{-1}(\mathfrak{P}_{g,1}^m) = \mathfrak{P}_{g,1}^m(G)$. Consequently, $P_{\mathfrak{P}}(G) : \mathfrak{P}_{g,1}^m(G) \rightarrow \mathfrak{P}_{g,1}^m$ is a fiber bundle. On the other hand, it follows from Propositions 2.2.12 and 2.2.13 that the fiber of $P_{\mathfrak{P}}(G)$ is in one-to-one correspondence with $\mathcal{R}_G(S_{g,1}^{(m)})$. Hence, $P_{\mathfrak{P}}(G) : \mathfrak{P}_{g,1}^m(G) \rightarrow \mathfrak{P}_{g,1}^m$ is a topological fiber bundle with fiber $\mathcal{R}_G(S_{g,1}^{(m)})$.

□

Now we will use Corollary 2.3.4 in order to prove that $\mathcal{H}(G)$ and $\mathcal{G}(G)$ are continuous maps. To this end, let us first remind of the notation which was introduced during the last sections. An element of $\mathfrak{H}_{g,1}^m(G)$ is given by the equivalence class $[E, \pi, X, A, u, \mathcal{P}, \mathcal{Q}, p_0]$. Here $\pi : E \rightarrow X$ is a flat pointed G -bundle with connection form A over a Riemann surface X of genus $g \geq 0$ with $m \geq 0$ punctures $\mathcal{P} = \{P_1, \dots, P_m\}$ and a dipole point $\mathcal{Q} = (Q, \chi)$. The dipole $Q \in X$ is fixed as the base point and $p_0 \in E_Q$ is the base point of the fiber bundle. We abbreviate such an element by $[E, \pi, X, A, u]$. A point in $\mathfrak{P}_{g,1}^m(G)$ is denoted by $((a_i, b_j)_{i,j}, \tilde{\Sigma})$. Here $(a_i, b_j)_{i,j}$ are the barycentric coordinates of the point and $\tilde{\Sigma} = (S_q : \dots : S_0)$ denotes the cell where it is contained in. We have $S_i = (\gamma_{i,j}; \sigma_i) \in G \wr \mathfrak{S}_p^0$ for $0 \leq i \leq q$ and $0 \leq j \leq p$. Recall that $((a_i, b_j)_{i,j}, \Sigma)$ is an element of $\mathfrak{P}_{g,1}^m$ where $\Sigma = (\sigma_q : \dots : \sigma_0)$. Moreover, we write $P_{\mathfrak{P}}(G) : \mathfrak{P}_{g,1}^m(G) \rightarrow \mathfrak{P}_{g,1}^m$ and $P_{\mathfrak{H}}(G) : \mathfrak{H}_{g,1}^m(G) \rightarrow \mathfrak{H}_{g,1}^m$ for the forgetful maps of the G -structure.

Proposition 2.3.5. *The Hilbert uniformization $\mathcal{H}(G) : \mathfrak{H}_{g,1}^m(G) \rightarrow \mathfrak{P}_{g,1}^m(G)$ is continuous.*

Proof. First we show that the diagram

$$\begin{array}{ccc}
\mathfrak{H}_{g,1}^m(G) & \xrightarrow{\mathcal{H}(G)} & \mathfrak{P}_{g,1}^m(G) \\
P_{\mathfrak{H}}(G) \downarrow & & \downarrow P_{\mathfrak{P}}(G) \\
\mathfrak{H}_{g,1}^m & \xrightarrow{\mathcal{H}} & \mathfrak{P}_{g,1}^m
\end{array} \tag{2.3}$$

of bundles with fiber $\mathcal{R}_G(S_{g,1}^{(m)})$ given by the projections $P_{\mathfrak{H}}(G)$ and $P_{\mathfrak{P}}(G)$ is commutative. By means of this result and Theorem 2.2.9, that is, \mathcal{H} is a homeomorphism, we will be in a position to show the continuity of $\mathcal{H}(G)$. Let $[E, \pi, X, A, u] \in \mathfrak{H}_{g,1}^m(G)$, then

$$\begin{aligned}
\mathcal{H} \circ P_{\mathfrak{H}}(G)([E, \pi, X, A, u]) &= \mathcal{H}([X, u]) = ((a_i, b_j)_{i,j}, \Sigma) \\
&= P_{\mathfrak{P}}(G)((a_i, b_j)_{i,j}, \tilde{\Sigma}) = P_{\mathfrak{P}}(G) \circ \mathcal{H}(G)([E, \pi, X, A, u]).
\end{aligned}$$

Consequently, Diagram (2.3) commutes. Moreover, $\mathcal{H}(G)$ is fiber preserving since $P_{\mathfrak{P}}(G)$ and $P_{\mathfrak{H}}(G)$ are just the forgetful maps of the G -structure. Next, we show that $\mathcal{H}(G)$ is continuous.

Let $\{U_\alpha, \phi_\alpha\}$ be a bundle atlas of $P_{\mathfrak{H}}(G) : \mathfrak{H}_{g,1}^m(G) \rightarrow \mathfrak{H}_{g,1}^m$ and let $\{U'_\lambda, \phi'_\lambda\}$ be a bundle atlas of $P_{\mathfrak{P}}(G) : \mathfrak{P}_{g,1}^m(G) \rightarrow \mathfrak{P}_{g,1}^m$. Here we choose the neighborhoods $\{U_\alpha\}$ and $\{U'_\lambda\}$ sufficiently small so that there are charts $\{U_\alpha, \chi_\alpha\}$ and $\{U'_\lambda, \chi'_\lambda\}$ which establish atlases for the topological manifolds $\mathfrak{H}_{g,1}^m$ and $\mathfrak{P}_{g,1}^m$, respectively. Then there are neighborhood bases $\{V_r\}$ and $\{V'_s\}$ of $\mathfrak{H}_{g,1}^m$ and $\mathfrak{P}_{g,1}^m$ respectively satisfying the following properties. For every r there exists α such that $\bar{V}_r \subseteq U_\alpha$ and for every s there exists λ such that $\bar{V}'_s \subseteq U'_\lambda$. In addition, for every s there exists r with $\mathcal{H}^{-1}(V'_s) = V_r$. For the first part we may choose $\{V_r\}$ and $\{V'_s\}$ sufficiently small while the second part is a consequence of Theorem 2.2.9. After fixing such neighborhood bases $\phi'_\lambda \circ \mathcal{H}(G) \circ \phi_\alpha^{-1}|_{V_r \times \mathcal{R}_G(S_{g,1}^{(m)})}$ is of the form (h_1, h_2) where $h_1 : V_r \rightarrow V'_s$ is a homeomorphism and $h_2 : \mathcal{R}_G(S_{g,1}^{(m)}) \rightarrow \mathcal{R}_G(S_{g,1}^{(m)})$. It remains to show that

h_2 is continuous. Let $y \in \mathcal{R}_G(S_{g,1}^{(m)})$ and set $y' = h_2(y)$. By commutativity of Diagram (2.3), we have

$$\phi'_\lambda \circ \mathcal{H}(G) \circ \phi_\alpha^{-1}|_{V_r \times \mathcal{R}_G(S_{g,1}^{(m)})} = \phi'_\lambda \circ P_{\mathfrak{P}}(G)^{-1} \circ \mathcal{H} \circ P_{\mathfrak{H}}(G) \circ \phi_\alpha^{-1}|_{V_r \times \mathcal{R}_G(S_{g,1}^{(m)})}.$$

The maps ϕ_α , ϕ'_λ and \mathcal{H} are homeomorphisms while $P_{\mathfrak{P}}(G)$ and $P_{\mathfrak{H}}(G)$ are continuous. Moreover, $P_{\mathfrak{H}}(G)$ is the forgetful map

$$\text{Pot}_{g,1}^m \times \mathcal{S}(S_{g,1}^{(m)}) \times \mathcal{R}_G(S_{g,1}^{(m)}) / \text{Diff}_{g,1}^m \rightarrow \text{Pot}_{g,1}^m \times \mathcal{S}(S_{g,1}^{(m)}) / \text{Diff}_{g,1}^m.$$

So by definition of the quotient topology on these direct products and since any canonical projection is an open map it follows for every small open neighborhood $N \subseteq \mathcal{R}_G(S_{g,1}^{(m)})$ of y' that $P_{\mathfrak{P}}(G)^{-1} \circ \mathcal{H} \circ P_{\mathfrak{H}}(G) \circ \phi_\alpha^{-1}(V_r \times N)$ is open.

Consequently, $\phi'_\lambda \circ \mathcal{H}(G) \circ \phi_\alpha^{-1}(V_r \times N)$ is open and so $h_2^{-1}(N)$ is an open set of $\mathcal{R}_G(S_{g,1}^{(m)})$. This implies the continuity of h_2 . Then the restriction of $\mathcal{H}(G)$ to all sets of the form $P_{\mathfrak{H}}(G)^{-1}(V_r)$ is continuous. But since $\{V_r\}$ is a neighborhood basis of $\mathfrak{H}_{g,1}^m$ such that for every r there exists α with $\bar{V}_r \subseteq U_\alpha$ the Hilbert uniformization $\mathcal{H}(G)$ is continuous on the whole space $\mathfrak{H}_{g,1}^m(G)$.

□

Proposition 2.3.6. *The inverse mapping of the Hilbert uniformization $\mathcal{G}(G) : \mathfrak{P}_{g,1}^m(G) \rightarrow \mathfrak{H}_{g,1}^m(G)$ is continuous.*

Proof. The proof works analogously as for Proposition 2.3.5. First we show that the diagram

$$\begin{array}{ccc}
\mathfrak{P}_{g,1}^m(G) & \xrightarrow{\mathcal{G}(G)} & \mathfrak{H}_{g,1}^m(G) \\
P_{\mathfrak{P}}(G) \downarrow & & \downarrow P_{\mathfrak{H}}(G) \\
\mathfrak{P}_{g,1}^m & \xrightarrow{\mathcal{G}} & \mathfrak{H}_{g,1}^m
\end{array} \tag{2.4}$$

of bundles with fiber $\mathcal{R}_G(S_{g,1}^{(m)})$ given by the projections $P_{\mathfrak{P}}(G)$ and $P_{\mathfrak{H}}(G)$ is commutative. Using this fact and that \mathcal{G} is a homeomorphism (see Theorem 2.2.9) the proposition will follow. Let $((a_i, b_j)_{i,j}, \tilde{\Sigma}) \in \mathfrak{P}_{g,1}^m(G)$, then

$$\begin{aligned}
P_{\mathfrak{H}}(G) \circ \mathcal{G}(G)((a_i, b_j)_{i,j}, \tilde{\Sigma}) &= P_{\mathfrak{H}}(G)([E, \pi, X, A, u]) = [X, u] \\
&= \mathcal{G}((a_i, b_j)_{i,j}, \Sigma) = \mathcal{G} \circ P_{\mathfrak{P}}(G)((a_i, b_j)_{i,j}, \tilde{\Sigma}).
\end{aligned}$$

Consequently, Diagram (2.4) is commutative. Moreover, $\mathcal{G}(G)$ is fiber preserving as $P_{\mathfrak{H}}(G)$ and $P_{\mathfrak{P}}(G)$ are the forgetful maps of the G -structure. Now we are in a position to show that $\mathcal{G}(G)$ is continuous.

Let $\{U_\alpha, \phi_\alpha\}$ be a bundle atlas of $P_{\mathfrak{H}}(G) : \mathfrak{H}_{g,1}^m(G) \rightarrow \mathfrak{H}_{g,1}^m$ and let $\{U'_\lambda, \phi'_\lambda\}$ be a bundle atlas of $P_{\mathfrak{P}}(G) : \mathfrak{P}_{g,1}^m(G) \rightarrow \mathfrak{P}_{g,1}^m$. As in the proof of the previous proposition we choose the neighborhoods $\{U_\alpha\}$ and $\{U'_\lambda\}$ sufficiently small so that there are charts $\{U_\alpha, \chi_\alpha\}$ and $\{U'_\lambda, \chi'_\lambda\}$ which establish atlases for the topological manifolds $\mathfrak{H}_{g,1}^m$ and $\mathfrak{P}_{g,1}^m$, respectively. Then there are neighborhood bases $\{V_r\}$ and $\{V'_s\}$ of $\mathfrak{H}_{g,1}^m$ and $\mathfrak{P}_{g,1}^m$ respectively satisfying the same properties as in Proposition 2.3.5. In particular, for every r there exists s such that $\mathcal{G}^{-1}(V_r) = V'_s$. After fixing such neighborhood bases $\phi_\alpha \circ \mathcal{G}(G) \circ \phi'_\lambda{}^{-1}|_{V'_s \times \mathcal{R}_G(S_{g,1}^{(m)})}$ is of the form (g_1, g_2) . Here $g_1 : V'_s \rightarrow V_r$ is a homeomorphism and $g_2 : \mathcal{R}_G(S_{g,1}^{(m)}) \rightarrow \mathcal{R}_G(S_{g,1}^{(m)})$ is a map for which we need to show its continuity. Let $y \in \mathcal{R}_G(S_{g,1}^{(m)})$ and set $y' = g_2(y)$. By

commutativity of Diagram (2.4), we have

$$\phi_\alpha \circ \mathcal{G}(G) \circ \phi'_\lambda{}^{-1}|_{V'_s \times \mathcal{R}_G(S_{g,1}^{(m)})} = \phi_\alpha \circ P_{\mathfrak{H}}(G)^{-1} \circ \mathcal{G} \circ P_{\mathfrak{P}}(G) \circ \phi'_\lambda{}^{-1}|_{V'_s \times \mathcal{R}_G(S_{g,1}^{(m)})}.$$

The maps ϕ_α , ϕ'_λ and \mathcal{G} are homeomorphisms while $P_{\mathfrak{H}}(G)$ and $P_{\mathfrak{P}}(G)$ are continuous. Moreover, $P_{\mathfrak{P}}(G)$ is the forgetful map of the G -structure which is defined by means of the projection maps $\Pi_{p,q} : \mathbb{P}_{p,q}(G) \rightarrow \mathbb{P}_{p,q}$ for all $0 \leq p \leq 2h$ and $0 \leq q \leq h$ (see Section 2.2). The maps $\Pi_{p,q}$ are just canonical projections. So by definition of the topology given by the geometric realization and since any canonical projection is an open map it follows for every small neighborhood $N \subseteq \mathcal{R}_G(S_{g,1}^{(m)})$ containing y' that $P_{\mathfrak{H}}(G)^{-1} \circ \mathcal{G} \circ P_{\mathfrak{P}}(G) \circ \phi'_\lambda{}^{-1}(V'_s \times N)$ is open. Hence, $\phi_\alpha \circ \mathcal{G}(G) \circ \phi'_\lambda{}^{-1}(V'_s \times N)$ is open and so $g_2^{-1}(N)$ is an open set of $\mathcal{R}_G(S_{g,1}^{(m)})$. This implies the continuity of g_2 . Then the restriction of $\mathcal{G}(G)$ to sets of the form $P_{\mathfrak{P}}(G)^{-1}(V'_s)$ is continuous. But since $\{V'_s\}$ is a neighborhood basis of $\mathfrak{P}_{g,1}^m$ such that for all s there is λ with $\bar{V}'_s \subseteq U'_\lambda$ the inverse of the Hilbert uniformization $\mathcal{G}(G)$ is continuous on the whole space $\mathfrak{P}_{g,1}^m(G)$.

□

According to Lemma 2.2.15, $\mathfrak{H}_{g,1}^m(G)$ is homotopy equivalent to $\mathcal{M}_{g,1}^{(m)}(G)$. For this reason, we obtain the following result for the moduli spaces of flat G -bundles over Riemann surfaces. It summarizes our key conclusions for the Hilbert uniformization of flat G -bundles and is at the heart of our combinatorial considerations.

Theorem 2.3.7.

- (1) *The Hilbert uniformization $\mathcal{H}(G) : \mathfrak{H}_{g,1}^m(G) \rightarrow \mathfrak{P}_{g,1}^m(G)$ is a homeomorphism.*

(2) The moduli space $\mathcal{M}_{g,1}^{(m)}(G)$ is homotopy equivalent to $\mathfrak{P}_{g,1}^m(G)$ for a fixed Lie group G , $m \geq 0$ and $g \geq 0$.

Proof.

(1) follows from Theorem 2.2.19, Propositions 2.3.5 and 2.3.6.

(2) follows from Lemma 2.2.15 and (1).

□

Remark 2.3.8. If $m \geq 1$ or G is either an abelian or countable and discrete Lie group then $\mathfrak{P}_{g,1}^m(G)$ is a topological manifold.

Proof. The remark follows from Corollary 2.1.6 and (2) of Theorem 2.3.7.

□

Example 2.3.9. We will apply (2) of Theorem 2.3.7 for the computation of the homology of the moduli space of 2-sheeted, unramified, pointed, connected coverings of the torus which has neither marked points nor punctures but one dipole point $\mathcal{M}_{1,1}[2]_0$. Notice that we can follow from Lemma 1.5.2 and Corollary 1.5.8 that $\mathcal{M}_{1,1}[2]_0$ is a 3-sheeted connected covering of $\mathcal{M}_{1,1}$. In analogy to Figure 6 of [1] all cells of $\mathfrak{P}_{1,1}[2]_0$ are depicted in Figure 2.9. We adapt our notation to [1].

By definition, $\text{Par}_{1,1}[2]$ is the geometric realization of the bisimplicial space $(\mathbb{P}_{p,q}[2], d'_i, d''_j)_{p,q,i,j}$ for $0 \leq p \leq 2$ and $q \in \{0, 1\}$ as introduced in Definition 2.2.16. Hence, we may use the cellular chain complex given by $(\mathbb{P}[2], \mathbb{P}'[2])$ in order to calculate the cohomology of the nondegenerated part $\mathfrak{P}_{1,1}[2]_0$. The moduli space $\mathcal{M}_{1,1}[2]_0$ is oriented since $\mathcal{M}_{1,1}$ is oriented and the action of the mapping class group on the fiber is orientation preserving. As $\mathcal{M}_{1,1}[2]_0$ is homotopy equivalent to $\mathfrak{P}_{1,1}[2]_0$ by Theorem 2.3.7 we may deduce the cohomology of $\mathcal{M}_{1,1}[2]_0$ from the cohomology of $\mathfrak{P}_{1,1}[2]_0$.

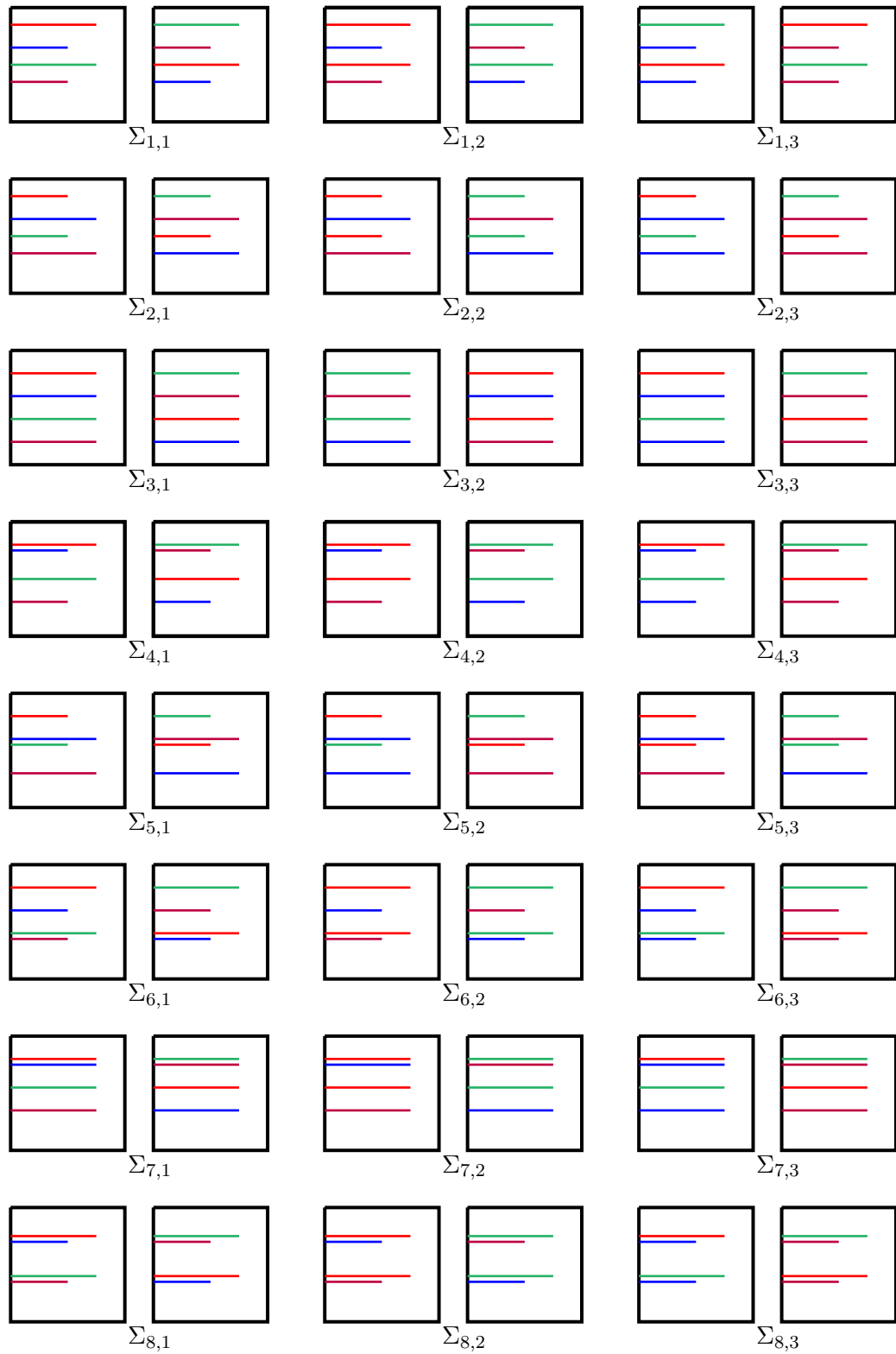

Figure 2.9: Cells of $\mathcal{M}_{1,1}[2]_0$
137

The dimension of the cell $\Sigma_{j,i}$ in Figure 2.9 equals the dimension of the cell Σ_i in Figure 6 of [1] for all $1 \leq i \leq 3$ and $1 \leq j \leq 8$. For $i = 1, 2, 3$ we have

$$\begin{aligned}
d'(\Sigma_{1,i}) &= -\Sigma_{3,i}, & d'(\Sigma_{2,i}) &= -\Sigma_{3,i}, \\
d'(\Sigma_{3,i}) &= 0, & d'(\Sigma_{4,i}) &= -\Sigma_{7,i}, \\
d'(\Sigma_{5,1}) &= -\Sigma_{7,3}, & d'(\Sigma_{6,1}) &= -\Sigma_{7,2}, \\
d'(\Sigma_{5,2}) &= -\Sigma_{7,1}, & d'(\Sigma_{6,2}) &= -\Sigma_{7,3}, \\
d'(\Sigma_{5,3}) &= -\Sigma_{7,2}, & d'(\Sigma_{6,3}) &= -\Sigma_{7,1}, \\
d'(\Sigma_{7,i}) &= 0, & d'(\Sigma_{8,i}) &= 0.
\end{aligned} \tag{2.5}$$

The results for d'' are given by

$$\begin{aligned}
d''(\Sigma_{1,1}) &= -\Sigma_{6,1} + \Sigma_{4,3} - \Sigma_{4,1}, & d''(\Sigma_{2,1}) &= \Sigma_{5,1} - \Sigma_{5,3} - \Sigma_{6,3}, \\
d''(\Sigma_{1,2}) &= -\Sigma_{6,2}, & d''(\Sigma_{2,2}) &= \Sigma_{5,3} - \Sigma_{5,1} - \Sigma_{6,1}, \\
d''(\Sigma_{1,3}) &= -\Sigma_{6,3} + \Sigma_{4,1} - \Sigma_{4,3}, & d''(\Sigma_{2,3}) &= -\Sigma_{6,2}, \\
d''(\Sigma_{3,1}) &= -\Sigma_{7,3} + \Sigma_{7,2} + \Sigma_{7,1}, & d''(\Sigma_{4,1}) &= -\Sigma_{8,1}, \\
d''(\Sigma_{3,2}) &= \Sigma_{7,3}, & d''(\Sigma_{4,2}) &= -\Sigma_{8,2}, \\
d''(\Sigma_{3,3}) &= \Sigma_{7,3}, & d''(\Sigma_{4,3}) &= -\Sigma_{8,3}, \\
d''(\Sigma_{5,1}) &= \Sigma_{8,3}, & d''(\Sigma_{6,1}) &= \Sigma_{8,1} - \Sigma_{8,3}, \\
d''(\Sigma_{5,2}) &= \Sigma_{8,2}, & d''(\Sigma_{6,2}) &= 0, \\
d''(\Sigma_{5,3}) &= \Sigma_{8,1}, & d''(\Sigma_{6,3}) &= \Sigma_{8,3} - \Sigma_{8,1}, \\
d''(\Sigma_{7,i}) &= 0, & d''(\Sigma_{8,i}) &= 0.
\end{aligned} \tag{2.6}$$

for $i = 1, 2, 3$ and we obtain the cellular chain complex

$$0 \longrightarrow \mathbb{Z}^6 \longrightarrow \mathbb{Z}^{12} \longrightarrow \mathbb{Z}^6 \longrightarrow 0 \tag{2.7}$$

with differential $d = d' + (-1)^q d''$ (see Definition 2.2.16). Note that by (2.5) and (2.6) there are only nonzero entries in degrees four, five and six. Thus,

we abstain in (2.7) from writing chains in all degrees. Further, we set

$$\begin{aligned} A_1 &= \Sigma_{1,1} - \Sigma_{2,1}, & B_1 &= \Sigma_{4,1} - \Sigma_{5,2}, & C_1 &= \Sigma_{4,1} - \Sigma_{6,3}, \\ A_2 &= \Sigma_{1,2} - \Sigma_{2,2}, & B_2 &= \Sigma_{4,2} - \Sigma_{5,3}, & C_2 &= \Sigma_{4,2} - \Sigma_{6,1}, \\ A_3 &= \Sigma_{1,3} - \Sigma_{2,3}, & B_3 &= \Sigma_{4,3} - \Sigma_{5,1}, & C_3 &= \Sigma_{4,3} - \Sigma_{6,2}. \end{aligned}$$

Then $d'(A_i) = 0$, $d'(B_i) = 0$ and $d'(C_i) = 0$ for all $i = 1, 2, 3$. So the remaining cycles of the d' -complex are A_i in degree 6, B_i and C_i in degree 5 and $\Sigma_{8,i}$ in degree 4 for $i = 1, 2, 3$. Hence, we may consider the cellular chain complex

$$0 \longrightarrow \mathbb{Z}^3 \xrightarrow{f} \mathbb{Z}^6 \xrightarrow{g} \mathbb{Z}^3 \xrightarrow{h} 0.$$

Since $d''(A_1 + A_2 + A_3) = 0$ it follows that the kernel of f is isomorphic to \mathbb{Z} and generated by $A_1 + A_2 + A_3$. The kernel of h is generated by $\Sigma_{8,i}$ for $i = 1, 2, 3$. On the other hand, the image of g is isomorphic to \mathbb{Z}^2 while it is generated by $-\Sigma_{8,1} - \Sigma_{8,2}$ and $\Sigma_{8,3}$. As a consequence, the quotient of the kernel of h and the image of g is isomorphic to \mathbb{Z} .

It remains to calculate the quotient of the kernel of g and the image of f . To this end, note that it follows from our previous calculations that the kernel of g is generated by $B_1 - B_2$, $C_1 - C_3$, $C_2 - B_2 + C_1$ and $B_3 - C_3 - C_1$ while the image of f is generated by $C_1 - C_3$, $C_2 - C_1 + B_3 - B_2$ and $C_3 - C_2 + B_2 - B_3$. Consequently, their quotient is isomorphic to \mathbb{Z}^2 and generated by $B_1 - B_2$ and $C_1 + C_2 - B_2$. Then all these results imply that the homology H_j of $(\mathbb{P}[2]_0, \mathbb{P}'[2]_0)^3$ is \mathbb{Z} if $j = 0, 2$, \mathbb{Z}^2 if $j = 1$ and trivial in all other cases. Thus, the cohomology of $\mathfrak{P}_{1,1}[2]_0$ and consequently the cohomology of $\mathcal{M}_{1,1}[2]_0$ is equal to these results. Since the cohomology groups of the moduli space are

³The subscript 0 denotes the part whose geometric realization is $\text{Par}_{1,1}[2]_0$.

torsion-free we may follow by means of the universal coefficient theorem that

$$H_i(\mathcal{M}_{1,1}[2]_0; \mathbb{Z}) \cong \begin{cases} \mathbb{Z}, & i = 0, 2 \\ \mathbb{Z}^2, & i = 1, \\ 0, & \text{else.} \end{cases}$$

We have already seen in Corollary 1.5.8 by means of purely combinatorial considerations that $\mathcal{M}_{1,1}[2]_0$ is connected, that is, $H_0(\mathcal{M}_{1,1}[2]_0) = \mathbb{Z}$. Moreover, from the multiplicativity of the Euler characteristic χ and from Lemma 1.2.8 it follows without any further computations that $\chi(\mathcal{M}_{1,1}[2]_0) = 0$ since $\chi(\mathcal{M}_{1,1}) = 0$ (see [1]). On the other hand, we obtain the same result from this homology computation.

Summarizing, we see that the Hilbert uniformization provides a constructive method to compute homology groups of the moduli spaces of flat G -bundles. However, due to the numerical complexity which arises from the huge number of cells of $\mathfrak{P}_{g,1}^m[K]$ the computation becomes difficult for large K and g . In [1] the cells were counted for $K = 1$ in some cases and there are examples of a dramatic increase in the number of cells. Furthermore, according to [37] the complexity of the cell complex grows exponentially with the number of sheets K . Nevertheless, it would be an interesting task to compute the homology groups for further moduli spaces by means of computer algebra programs.

2.4 Stratification of moduli spaces of flat G -bundles

In the previous section a cell decomposition was constructed by means of the Hilbert uniformization. Bearing this cell decomposition in mind, we specify a stratum of filtered classifying spaces which we can identify with a disjoint

union of moduli spaces of flat G -bundles. A strong motivation for studying such a filtration is that it provides a method to calculate the cohomology of a large class of certain groups. We will explain this later in more detail. First let us recall the bar construction to realize the classifying space of a group G .

Definition 2.4.1. Let G be a topological group and let Y and Z be a left and right G -space, respectively. We define a simplicial space $B(Y, G, Z)$ by taking $Y \times G^n \times Z$ as the n -simplices $B_n(Y, G, Z)$. We write n -simplices in the form $(y|g_n|\dots|g_1|z)$ for $y \in Y$, $z \in Z$ and $g_i \in G$ for $1 \leq i \leq n$. The reason for the reversed numbering will become apparent in the sequel. The face maps d_i are defined on $B_n(Y, G, Z)$ as

$$d_i(y|g_n|\dots|g_1|z) = \begin{cases} (y|g_n|\dots|g_1|z), & i = 0 \\ (y|g_n|\dots|g_{i+1}g_i|\dots|g_1|z), & 1 \leq i \leq n-1 \\ (yg_n|\dots|g_1|z), & i = n. \end{cases}$$

Moreover, the degeneracy maps are given by

$$s_i(y|g_n|\dots|g_1|z) = (y|g_n|\dots|g_{i+1}|e|g_i|\dots|g_1|z)$$

for $0 \leq i \leq n$. We set $E_n(G)$ for the space of n -simplices $B_n(*, G, G)$ and $E(G) = B(*, G, G)$ where $*$ denotes the one-point space. The geometric realization EG of $E(G)$ is defined as the quotient $\coprod_{n \geq 0} E_n(G) \times \Delta^n / \sim$, where the identification \sim is given by $(d_i x_n, t_{n+1}) \sim (x_n, \delta_i t_{n+1})$ and $(s_i x_n, t_{n-1}) \sim (x_n, \sigma_i t_{n-1})$ for all $x_n \in E_n(G)$, $t_{n+1} \in \Delta^{n+1}$, $t_{n-1} \in \Delta^{n-1}$.

The maps δ_i and σ_i are the standard face and degeneracy maps on the standard n -simplex Δ^n , that is, $\delta_i(t_n, \dots, t_0) = (t_n, \dots, t_{i+1} + t_i, \dots, t_0)$ and $\sigma_i(t_n, \dots, t_0) = (t_n, \dots, t_i, 0, t_{i-1}, \dots, t_0)$.

The quotient $BG = EG/G$ is the *classifying space* of G . Here we divide by the G -action from the right on itself by multiplication. The space BG is the geometric realization of $B(*, G, *)$ where we denote by $B_n(G)$ the space of n -simplices $B_n(*, G, *)$. For a cell of EG and BG we write $(g_k : \dots : g_0)$ and $[g_k : \dots : g_0]$, respectively. In the inhomogeneous notation a cell is denoted by $(g_k | \dots | g_0)$ for EG and $[g_k | \dots | g_0]$ for BG .

Definition 2.4.2. Let G be a finite group which we think of as a subgroup of a symmetric group \mathfrak{S}_K for an appropriate $K \in \mathbb{N}$. Then $G \wr \mathfrak{S}_p^0$ is considered as a subgroup of $\mathfrak{S}_{K(p+1)}$. Using the word length norm wl on the symmetric group with respect to all transpositions (see Example 2.2.5) we define

$$N((a_q : \dots : a_0)) = N((a_q a_{q-1}^{-1} | \dots | a_1 a_0^{-1})) = wl(a_q a_{q-1}^{-1}) + \dots + wl(a_1 a_0^{-1})$$

for every cell $(a_q : \dots : a_0)$ of $E(G \wr \mathfrak{S}_p^0)$ and

$$N([a_q : \dots : a_0]) = N([a_q a_{q-1}^{-1} | \dots | a_1 a_0^{-1}]) = wl(a_q a_{q-1}^{-1}) + \dots + wl(a_1 a_0^{-1})$$

for every cell $[a_q : \dots : a_0]$ of $B(G \wr \mathfrak{S}_p^0)$ where $p \geq 0$ and $q \geq 0$. Moreover, we define the following filtrations and strata, respectively:

$$\mathcal{F}_h E(G \wr \mathfrak{S}_p) = \bigcup_{q \geq 0} \{(a_q : \dots : a_0) | a_i \in G \wr \mathfrak{S}_p, N((a_q : \dots : a_0)) \leq h\},$$

$$\mathcal{F}_h B(G \wr \mathfrak{S}_p) = \bigcup_{q \geq 0} \{[a_q : \dots : a_0] | a_i \in G \wr \mathfrak{S}_p, N([a_q : \dots : a_0]) \leq h\},$$

$$\mathcal{F}_{(h)} B(G \wr \mathfrak{S}_p) = \mathcal{F}_h B(G \wr \mathfrak{S}_p) - \mathcal{F}_{h-1} B(G \wr \mathfrak{S}_p).$$

Lemma 2.4.3. *The projection $p_{(h)} : \mathcal{F}_{(h)} E(G \wr \mathfrak{S}_p) \rightarrow \mathcal{F}_{(h)} B(G \wr \mathfrak{S}_p)$ is a trivial bundle.*

Proof. To show the assertion it is sufficient to find a global section of $p_{(h)}$. For every cell $[a_q : \dots : a_0]$ of $B(G \wr \mathfrak{S}_p^0)$ where $p \geq 0$ and $q \geq 0$ and every

$g \in G$ the norm N satisfies

$$N([a_q g : \dots : a_0 g]) = wl(a_q g g^{-1} a_{q-1}^{-1}) + \dots + wl(a_1 g g^{-1} a_0^{-1}) = N([a_q : \dots : a_0]).$$

Thus, a global section $s_{(h)} : \mathcal{F}_{(h)}B(G \wr \mathfrak{S}_p) \rightarrow \mathcal{F}_{(h)}E(G \wr \mathfrak{S}_p)$ can be defined as follows. Let $x \in \mathcal{F}_{(h)}B(G \wr \mathfrak{S}_p)$ that we denote by $((t_k)_{k \geq 0}, [a_q : \dots : a_0])$ where $(t_k)_{k \geq 0}$ are the barycentric coordinates of x . Then a global section of $p_{(h)}$ is given by $s_{(h)}(x) = ((t_k)_{k \geq 0}, (a_q : \dots : a_0) a_0^{-1})$.

□

Notation. We consider the geometric realization $\coprod_{p,q} (G \wr \mathfrak{S}_p^0)^{q+1} \times \Delta^p \times \Delta^q / \sim$ where \sim is the identification with respect to the face maps d'_i and d''_j of Definition 2.2.16 and $0 \leq q \leq h$, $0 \leq p \leq 2h$ for $h = 2g + m$.

Let $\mathcal{F}_{(h)}B(G \wr \mathfrak{S}_*)$ be the space of those cells whose norm N equals h . Note that in contrast to the stratum of Definition 2.4.2 the index of the symmetric group is not fixed. More precisely, we consider here a whole family of wreath products of symmetric groups.

Theorem 2.4.4. *The Hilbert uniformization $\mathcal{H}(G)$ induces the homotopy equivalence*

$$\coprod_{h=|G|(2g+m)} \mathcal{M}_{g,1}^{(m)}(G) \longrightarrow \mathcal{F}_{(h)}B(G \wr \mathfrak{S}_*)$$

for a finite group G of order $|G|$.

Proof. The theorem holds in the case of the trivial group $G = \langle e \rangle$ by [12]. Hence, there is a homotopy equivalence between the stratum $\mathcal{F}_{(h)}B\mathfrak{S}_*$ of symmetric groups and a disjoint union of moduli spaces of Riemann surfaces. The centerpiece of the proof for general finite groups G is the homeomorphism given by the Hilbert uniformization. More precisely, we will show that

$\coprod_{h=|G|(2g+m)} \mathfrak{P}_{g,1}^m(G)$ is in bijection with $\mathcal{F}_{(h)}B(G \wr \mathfrak{S}_*)$ so that the assertion

will follow from Theorem 2.3.7.

Let $C \in \mathfrak{P}_{g,1}^m(G)$ with $C = ((a_i, b_j)_{i,j}, \tilde{\Sigma})$ where $\tilde{\Sigma} = (S_q : \dots : S_0)$ and $S_i = (\gamma_{i,p}, \dots, \gamma_{i,0}; \sigma_i)$ for $0 \leq i \leq q$ as before. We use the inhomogeneous notation for $\tilde{\Sigma}$ in order to define a map $F : \coprod_{h=|G|(2g+m)} \mathfrak{P}_{g,1}^m(G) \rightarrow \mathcal{F}_{(h)}B(G \wr \mathfrak{S}_*)$. So we set $T_i = S_i \circ S_{i-1}^{-1}$. Then $[T_q | \dots | T_1]$ defines a cell in $\mathcal{F}_{(h)}B(G \wr \mathfrak{S}_*)$ by (F1) and (F4) so that $((a_i, b_j)_{i,j}, [T_q | \dots | T_1])$ is an element of $\mathcal{F}_{(h)}B(G \wr \mathfrak{S}_*)$. This defines F for which we have to show injectivity and surjectivity.

First we show that F is injective. Using the same notation as above let $((a_i, b_j)_{i,j}, [T_q | \dots | T_1]) = ((a'_i, b'_j)_{i,j}, [T'_q | \dots | T'_1])$. Then $(a_i, b_j)_{i,j} = (a'_i, b'_j)_{i,j}$ and $[T_q | \dots | T_1] = [T'_q | \dots | T'_1]$. Thus, $T_i = T'_i$ and so $S_i \circ S_{i-1}^{-1} = S'_i \circ S'_{i-1}^{-1}$ for all $1 \leq i \leq q$. Because of (F2) $S_0 = (e, \dots, e; \omega_p) = S'_0$ so that it follows inductively that $S_i = S'_i$ for all $1 \leq i \leq q$. Consequently, F is injective for $((a_i, b_j)_{i,j}, \tilde{\Sigma}) = ((a'_i, b'_j)_{i,j}, \tilde{\Sigma}')$.

To show the surjectivity of F let $[V_q | \dots | V_1] \in \mathcal{F}_{(h)}B(G \wr \mathfrak{S}_*)$. Then there is $p \geq 0$ with $[V_q | \dots | V_1] \in \mathcal{F}_{(h)}B(G \wr \mathfrak{S}_p)$. As the theorem holds in case of the trivial group (F1) is satisfied. Because of (F2) we choose $S_0 = (e, \dots, e; \omega_p)$ where $e \in G$ is the identity element. Then the formula $S_i = V_i \circ S_{i-1}$ defines $S_i \in G \wr \mathfrak{S}_p^0$ for all $1 \leq i \leq q$. Since $V_i \in G \wr \mathfrak{S}_p$ it can be considered as an element of $G \wr \mathfrak{S}_p^0$ fixing every element of the form $(0, \xi)$ for $\xi \in G$. Moreover, $S_0(p, \xi) = (0, \xi)$ for every $\xi \in G$ and it follows inductively that $S_i(p, \xi) = (0, \sigma_i(\xi))$ for all $1 \leq i \leq q$. It remains to show (F4). Each V_i is of the form $(h_{i,p}, \dots, h_{i,1}; \nu_i)$ where $h_{i,j} \in G$ and $\nu_i \in \mathfrak{S}_p$ for $1 \leq i \leq q$ and $1 \leq j \leq p$. As G is a finite group of order $|G|$ we think of G as a subgroup of $\mathfrak{S}_{|G|}$. Hence, we may identify V_i with an element of $\mathfrak{S}_{|G|p}$ for all $1 \leq i \leq q$. Let $\nu_i = \mu_1^{(i)} \dots \mu_{r_i}^{(i)}$ be the disjoint cycle decomposition of ν_i . We write $(m_{\alpha,1}^{(i)}, \dots, m_{\alpha,s_\alpha}^{(i)})$ for the cycle $\mu_\alpha^{(i)}$ for $1 \leq \alpha \leq r_i$ and $1 \leq i \leq q$. Analogously, let $V_i = \tilde{\mu}_1^{(i)} \dots \tilde{\mu}_{\tilde{r}_i}^{(i)}$ be the disjoint cycle decomposition of V_i as

an element of $\mathfrak{S}_{|G|p}$. Then $\tilde{\mu}_j^{(i)}$ is of the form

$$(m_{\alpha,1}^{(i),\beta_1}, \dots, m_{\alpha,s_\alpha}^{(i),\beta_1}, \dots, m_{\alpha,1}^{(i),\beta_j}, \dots, m_{\alpha,s_\alpha}^{(i),\beta_j}) \quad (2.8)$$

if $\Pi(\tilde{\mu}_j^{(i)}) = \mu_\alpha^{(i)}$ for $1 \leq j \leq t_i$. It follows that $wl(\tilde{\mu}_j^{(i)}) \geq wl(\mu_\alpha^{(i)})$. Note that for each cycle $\mu_\alpha^{(i)}$ there is a maximal number of $|G|$ cycles $\tilde{\mu}_j^{(i)}$ with $\Pi(\tilde{\mu}_j^{(i)}) = \mu_\alpha^{(i)}$. Hence,

$$\sum_{1 \leq i \leq q} wl(V_i) = \sum_{i,j} wl(\tilde{\mu}_j^{(i)}) \geq |G| \sum_{i,\alpha} wl(\mu_\alpha^{(i)}) = |G|(2g+m). \quad (2.9)$$

By assumption, we have $wl(V_1) + \dots + wl(V_q) = |G|(2g+m)$ and it follows $\sum_j wl(\tilde{\mu}_j^{(i)}) = |G| \sum_\alpha wl(\mu_\alpha^{(i)})$. Thus, each $\tilde{\mu}_j^{(i)}$ has the same length as $\mu_\alpha^{(i)}$ if $\Pi(\tilde{\mu}_j^{(i)}) = \mu_\alpha^{(i)}$. Otherwise, Equation (2.9) would be a strict inequality because of the cycle form of $\tilde{\mu}_j^{(i)}$ given in (2.8). Consequently, over each disjoint cycle of ν_i of length l lie only cycles of length l of V_i .

□

Corollary 2.4.5. *The following statements hold for any finite group G .*

- (1) *The stratum $\mathcal{F}_{(h)}B(G \wr \mathfrak{S}_*)$ is homeomorphic to a topological manifold.*
- (2) *The stratum $\mathcal{F}_{(h)}B(G \wr \mathfrak{S}_*)$ is homotopy equivalent to the coproduct*

$$\coprod_{h=2g|G|} \mathcal{M}_{g,1}[|G|]^G.$$

Proof.

- (1) follows from Theorem 2.3.7 and Theorem 2.4.4.
- (2) follows from Theorem 2.4.4 and Lemma 2.1.4 as $\mathcal{M}_{g,1}[|G|]^G$ is homeomorphic to $\mathcal{M}_{g,1}(G)$.

□

Remark 2.4.6. Let $[T_q] \dots [T_1]$ be a cell of $\text{Par}_{g,1}^m(G)$ in the inhomogeneous notation and let G be a finite group of order $|G|$. For $T_i = (\delta_{i,j}; \tau_i)$ which we consider as an element of $\mathfrak{S}_{|G|p}$ the condition $wl(T_i) \geq |G| wl(\tau_i)$ is satisfied. It follows from Theorem 2.4.4 that the induced coverings are ramified if $N([T_q] \dots [T_1])$ is greater than $|G|N([\tau_q] \dots [\tau_1])$. On the other hand, by definition of the wreath product $N([T_q] \dots [T_1]) < |G|N([\tau_q] \dots [\tau_1])$ can never hold. Consequently, elements of the filtration which correspond to degenerated cells of $\text{Par}_{g,1}^m(G)$ can be identified with ramified coverings or coverings of surfaces with a finite number of singularities. See Section 4.4 of [11] for various examples how such singularities can arise in the context of the Hilbert uniformization.

Initiated by the work [1], the filtration $\mathcal{F}_{(h)}BG$ (as in Definition 2.4.2) was studied for so-called factorable groups G in [53] in order to construct complexes for the calculation of the group cohomology of G . To this end, by means of the norm filtration, a spectral sequence was constructed which converges to the cohomology of the group. One outstanding property of factorable groups is that the spectral sequence collapses in the E_2 -term. The groups of Theorem 2.4.4 are factorable with respect to the norm of the semidirect product induced by the trivial norm on G and the word length norm on the symmetric group with respect to the generating set of all transpositions (see Section 3.2 and 3.3 of [53]). Consequently, this theorem establishes an interesting connection between the moduli spaces of flat G -bundles and the group cohomology of certain wreath products.

As a further consequence we obtain a large class of groups for which the norm filtration is a topological manifold. See also Section 5 of [1] for similar considerations.

2.5 H-space structure of the moduli space of flat G -bundles

In this section we will show that the disjoint union of moduli spaces $\coprod_{g \geq 0} \mathcal{M}_{g,1}(G)$ inherits an H-space structure. Further, we will consider its homology ring which is a Pontryagin ring. To this end, we will construct a multiplication on $\coprod_{g \geq 0} \mathfrak{P}_{g,1}(G)$. For reasons of simplification we assume $m = 0$ for the rest of this section, that is, there are neither marked points nor punctures on the surfaces. Many of the methods we apply in the following were developed in [10].

Lemma 2.5.1. *For every Lie group G there exists a continuous product*

$$\mathfrak{m} : \mathcal{R}_G(S_{g_1,1}) \times \mathcal{R}_G(S_{g_2,1}) \rightarrow \mathcal{R}_G(S_{g_1+g_2,1}).$$

Proof. The fundamental group of $S_{g,1}$ equals the fundamental group of a closed, oriented surface S_g of genus g . It can be represented as the free group F_{2g} on $2g$ generators $\{a_i, b_i\}_{1 \leq i \leq g}$ divided by the relation $\prod_{1 \leq i \leq g} [a_i, b_i] = 1$. To define \mathfrak{m} we proceed as follows. Let $S_{g_1,1} \# S_{g_2,1}$ denote the connected sum of $S_{g_1,1}$ and $S_{g_2,1}$ along small disks around the dipole points. The explicit construction of the connected sum of $S_{g_1,1}$ and $S_{g_2,1}$ is given below in this section. Let $\{A_i, B_i\}_{1 \leq i \leq g_1}$ and $\{A'_j, B'_j\}_{1 \leq j \leq g_2}$ be fixed free generating sets of $\pi_1(S_{g_1,1})$ and $\pi_1(S_{g_2,1})$ as introduced in see Section 1.1, respectively. Then there is an induced generating set of $\pi_1(S_{g_1,1} \# S_{g_2,1})$. For this, let $h_\nu : S_{g_\nu,1} \rightarrow S_{g_1,1} \# S_{g_2,1}$ be the natural maps from the gluing construction for $\nu = 1, 2$. We consider simple closed curves α_i and β_i in $S_{g_1,1}$ whose homotopy class equals A_i and B_i for all $1 \leq i \leq g_1$, respectively. Analogously, we denote by α'_j and β'_j simple closed curves in $S_{g_2,1}$ representing A'_j and B'_j

in the fundamental group for all $1 \leq j \leq g_2$. The set of homotopy classes $\{[h_1(\alpha_i)], [h_1(\beta_i)], [h_2(\alpha'_j)], [h_2(\beta'_j)]\}$ for $1 \leq i \leq g_1$ and $1 \leq j \leq g_2$ defines a generating set of $\pi_1(S_{g_1,1} \# S_{g_2,1})$. We set

$$A''_k = \begin{cases} [h_1(\alpha_i)], & k = i \\ [h_1(\alpha'_j)], & k = j + g_1 \end{cases} \quad \text{and} \quad B''_k = \begin{cases} [h_1(\beta_i)], & k = i \\ [h_1(\beta'_j)], & k = j + g_1. \end{cases}$$

By the theorem of Seifert–van Kampen there exists a homomorphism

$$\varphi : \pi_1(S_{g_1,1}) * \pi_1(S_{g_2,1}) \rightarrow \pi_1(S_{g_1,1} \# S_{g_2,1})$$

given by

$$\varphi(C) = \begin{cases} A''_k, & C = A_i \text{ and } k = i \\ B''_k, & C = B_i \text{ and } k = i \\ A''_k, & C = A'_j \text{ and } k = j + g_1 \\ B''_k, & C = B'_j \text{ and } k = j + g_1. \end{cases} \quad (2.10)$$

For every pair (ρ_1, ρ_2) in $\mathcal{R}_G(S_{g_1,1}) \times \mathcal{R}_G(S_{g_2,1})$ we define $\mathbf{m}(\rho_1, \rho_2)$ by

$$\mathbf{m}(\rho_1, \rho_2)(A''_k) = \begin{cases} \rho_1(A_i), & k = i \\ \rho_2(A'_j), & k = j + g_1, \end{cases}$$

$$\mathbf{m}(\rho_1, \rho_2)(B''_k) = \begin{cases} \rho_1(B_i), & k = i \\ \rho_2(B'_j), & k = j + g_1. \end{cases}$$

In particular, the equation

$$\prod_k [\mathbf{m}(\rho_1, \rho_2)(A'_k), \mathbf{m}(\rho_1, \rho_2)(B'_k)] = \prod_i [\rho_1(A_i), \rho_1(B_i)] \prod_j [\rho_2(A'_j), \rho_2(B'_j)] = 1 \quad (2.11)$$

is satisfied as desired. Moreover, \mathbf{m} is continuous. For this note that $\mathcal{R}_G(S_{g,1})$ is equipped with the quotient topology of G^{2g} after having chosen a generating set of $\pi_1(S_{g,1})$. On the one hand, we divide by the relation given on the left hand side of (2.11). On the other hand, we divide out the relation given on the right hand side of (2.11). Since the set

$$\{(A_\lambda, B_\lambda)_{1 \leq \lambda \leq g} \in G^{2g} \mid \prod_{1 \leq \lambda \leq g_1} [A_\lambda, B_\lambda] = 1, \quad \prod_{g_1+1 \leq \lambda \leq g_1+g_2=g} [A_\lambda, B_\lambda] = 1\}$$

is contained in the set $\{(A_\lambda, B_\lambda)_{1 \leq \lambda \leq g} \in G^{2g} \mid \prod_{1 \leq \lambda \leq g} [A_\lambda, B_\lambda] = 1\}$ the assumption on the continuity follows.

□

Lemma 2.5.2. *The operation \mathbf{m} is associative.*

Proof. By construction of \mathbf{m} in Lemma 2.5.1 and after choosing appropriate generating sets as described in the proof of Lemma 2.5.1, the associativity of \mathbf{m} is a consequence of the commutativity of the diagram

$$\begin{array}{ccc} \pi_1(S_{a,1}) * \pi_1(S_{b,1}) * \pi_1(S_{c,1}) & \xrightarrow{\varphi * id} & \pi_1(S_{a,1} \# S_{b,1}) * \pi_1(S_{c,1}) \\ id * \varphi \downarrow & & \downarrow \varphi \\ \pi_1(S_{a,1}) * \pi_1(S_{b,1} \# S_{c,1}) & \xrightarrow{\varphi} & \pi_1(S_{a,1} \# S_{b,1} \# S_{c,1}) \end{array}$$

where a , b and c are natural numbers.

□

Then the next evident lemma describes the neutral element.

Lemma 2.5.3. *The neutral element for \mathfrak{m} is defined by the single point $\mathcal{R}_G(S_{0,1})$.*

□

Notation. We set \mathcal{R}_G for $\coprod_{g \geq 0} \mathcal{R}_G(S_{g,1})$ and $\mathfrak{P}(G)$ for $\coprod_{g \geq 0} \mathfrak{P}_{g,1}(G)$.

Bearing the construction idea for \mathfrak{m} in mind we will specify a product for $\mathfrak{P}(G)$ which is compatible with \mathfrak{m} . To simplify the notation we introduce the following conventions where we partially follow [10]. For every $C \in \mathfrak{P}_{g,1}(G)$, there exists an extended PSD $Y(C)$ with gluing functions determined by C . On the other hand, every extended PSD Y with appropriate gluing functions induces an element $C(Y) \in \mathfrak{P}_{g,1}(G)$. In the sequel, we will assume without further remarks that $Y(C)$ is equipped with all gluing functions $(\gamma_{i,j}, \sigma_i)_{i,j}$. Let $\{x_i\}_{0 \leq i \leq q}$ and $\{y_j\}_{0 \leq j \leq p}$ be the values of the critical points of u and v , respectively and let $\{z_{i,j}\}_{0 \leq i \leq q, 0 \leq j \leq p}$ be the induced grid points of Y . The numbers $y_+(Y) = \max_j \{y_j\}$ and $y_-(Y) = \min_j \{y_j\}$ denote the y -coordinate of the highest and lowest slit end point in the plane, respectively. Analogously, we define $x_+(Y) = \max_i \{x_i\}$ and $x_-(Y) = \min_i \{x_i\}$. For $z \in \mathbb{C}$ denote by $Y + z$ the translated PSD such that the coordinates of the grid points are given by $z_{i,j} + z$ while rY is the PSD whose grid points have coordinates $rz_{i,j}$ for a positive real number r .

Let Y and Y' be two PSDs such that $C = C(Y)$ and $C' = C(Y')$ are contained in $\mathfrak{P}_{g,1}(G)$ and $\mathfrak{P}_{g',1}(G)$, respectively. Then $C = ((a_i, b_j), (\gamma_{i,j}, \sigma_i))$ for $0 \leq i \leq q$, $0 \leq j \leq p$ and $C' = ((a'_k, b'_l), (\gamma'_{k,l}, \sigma'_k))$ for $0 \leq k \leq q'$, $0 \leq l \leq p'$. We define a new PSD by transforming Y into $Y - \sqrt{-1}(y_-(Y) - \frac{1}{2})$ and Y' into $Y' - \sqrt{-1}(y_+(Y') + \frac{1}{2})$. Then all slits of Y lie in the upper half plane while all slits of Y' are contained in the lower half plane. Finally, Y' is moved to the right so that no slit end points of Y and Y' lie on the same

levels. We obtain a new assembled extended PSD $Y + Y'$. The forthcoming figure illustrates the geometric idea of this description (see Figure 2.10).

More precisely, the barycentric coordinates (a''_α, b''_β) for $0 \leq \alpha \leq p + p'$ and $0 \leq \beta \leq q + q'$ of $C(Y + Y')$ are given by

$$a''_\alpha = \begin{cases} \frac{a'_\alpha}{3}, & 0 \leq \alpha \leq q' - 1 \\ \frac{a'_q + a_0 + 1}{3}, & \alpha = q' \\ \frac{a_{\alpha - q'}}{3}, & q' + 1 \leq \alpha \leq q + q', \end{cases}$$

$$b''_\beta = \begin{cases} \frac{b'_\beta}{3}, & 0 \leq \beta \leq p' - 1 \\ \frac{b'_{p'} + b_0 + 1}{3}, & \beta = p' \\ \frac{b'_{\beta - p'}}{3}, & p' + 1 \leq \beta \leq p + p'. \end{cases}$$

This PSD is well-defined since y_+ , y_- and x_+ are continuous and it determines an element $C(Y + Y')$ in $\text{Par}_{g+g',1}(G)$. We will show that $C(Y + Y')$ is nondegenerate because it is defined by two nondegenerate elements. To this end, the new gluing functions $(\gamma''_{\alpha,\beta}, \sigma''_\alpha)$ need to be made precise.

$$\sigma''_\alpha(\beta) = \begin{cases} \sigma'_\alpha(\beta), & 0 \leq \beta < p', 0 \leq \alpha' \leq q' \\ \sigma_0(\beta - p'), & p' \leq \beta \leq p + p', 0 \leq \alpha' \leq q' \\ \sigma'_{q'}(\beta), & 0 \leq \beta < p', q' \leq \alpha \leq q' + q \\ \sigma_{\alpha - q'}(\beta - p'), & p' \leq \beta \leq p + p', q' \leq \alpha \leq q' + q, \end{cases} \quad (2.12)$$

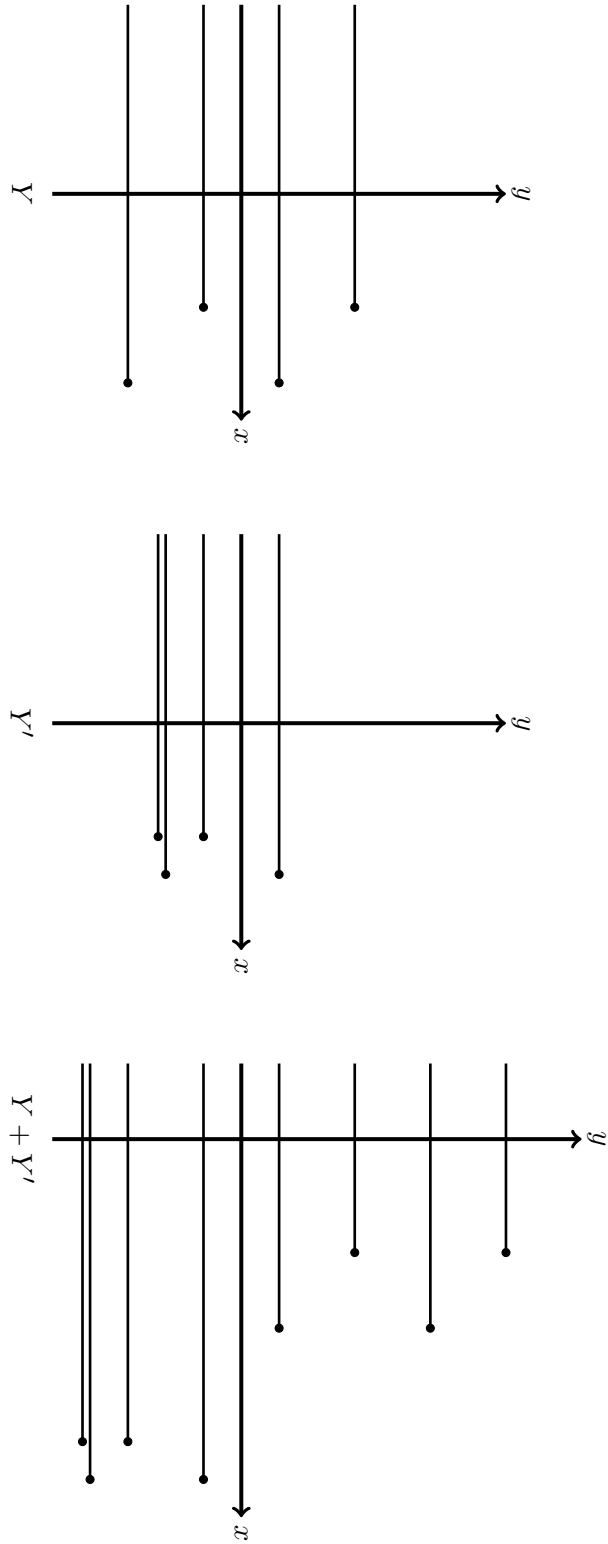

Figure 2.10: Assembling two PSDs

$$\gamma''_{\alpha,\beta} = \begin{cases} \gamma'_{\alpha,\beta}, & 0 \leq \alpha < q', 0 \leq \beta < p' \\ \gamma'_{q',\beta}, & q' \leq \alpha \leq q' + q, 0 \leq \beta < p' \\ \gamma_{0,\beta-p'}, & 0 \leq \alpha < q', p' \leq \beta \leq p' + p \\ \gamma_{\alpha-q',\beta-p'}, & q' \leq \alpha \leq q' + q, p' \leq \beta \leq p' + p. \end{cases} \quad (2.13)$$

Since σ''_{α} acts on $\underline{p+p'}_0$ by σ_i and σ'_k it follows that $(\gamma''_{\alpha,\beta}, \sigma''_{\alpha})$ is an element of $(G \wr \mathfrak{S}_{p+p'}^0)^{q+q'+1}$. Condition (F4) is satisfied because the norm of T'' equals the sum of the norms of T and T' where we use T, T' and T'' for the inhomogeneous notation of S, S' and S'' , respectively. Moreover, (F2) holds by Remark 2.2.10 since

$$\gamma''_{0,\beta} = \begin{cases} \gamma'_{0,\beta}, & 0 \leq \beta < p' \\ \gamma_{0,\beta}, & p' \leq \beta \leq p' + p \end{cases} = e,$$

$$\sigma''_0(\beta) = \begin{cases} \sigma'_0(\beta), & 0 \leq \beta < p' \\ \sigma_0(\beta - p'), & p' \leq \beta \leq p' + p. \end{cases}$$

Finally, (F3) is satisfied as

$$\gamma''_{\alpha,p+p'} = \begin{cases} \gamma_{0,p}, & 0 \leq \alpha < q' \\ \gamma'_{\alpha-q',p}, & q' \leq \alpha \leq q' + q \end{cases} = e,$$

$$\sigma''_{\alpha}(p+p') = \begin{cases} \sigma_0(p), & 0 \leq \alpha < q' \\ \sigma'_{\alpha-q'}(p'), & q' \leq \alpha \leq q' + q. \end{cases}$$

Consequently, $C(Y + Y') \in \mathfrak{P}_{g+g',1}(G)$ and we write $C(Y) + C(Y')$ for $C(Y + Y')$. Thus, $+$ is well-defined for any two elements of $\mathfrak{P}(G)$. For a

geometric illustration of the construction of the gluing functions consider Figure 2.11.

Motivated by the previous construction we introduce the following definition.

Definition 2.5.4. For every Lie group G and $g, g' \geq 0$ define

$$\begin{aligned}\mu : \mathfrak{P}_{g,1}(G) \times \mathfrak{P}_{g',1}(G) &\rightarrow \mathfrak{P}_{g+g',1}(G), \\ \mu : (C, C') &\mapsto C + C'.\end{aligned}$$

In view of the homeomorphism given by the Hilbert uniformization we may interpret the operation of 2.5.4 geometrically in terms of flat G -bundles over Riemann surfaces. As this was carried out for the trivial group $G = \langle e \rangle$ in Chapter 1 of [10] we will focus on the flat G -bundle structure. To simplify technical details we assume that G is connected.

Let $C \in \mathfrak{P}_{g,1}(G)$ and $C' \in \mathfrak{P}_{g',1}(G)$ such that $\mathcal{G}(G)(C) = [E, \pi, X, A, u]$ and $\mathcal{G}(G)(C') = [E', \pi', X', A', u']$ are elements of $\mathfrak{H}_{g,1}(G)$ and $\mathfrak{H}_{g',1}(G)$, respectively. As was discussed in Section 2.2, there are holomorphic functions $w = u + \sqrt{-1}v$ and $w' = u' + \sqrt{-1}v'$ whose images are the parallel slit domains associated with X and X' , respectively. The surfaces X and X' are glued together along two disks D and D' which are defined by $v < y_-(Y) - \frac{1}{2}$ and $v' > y_+(Y') + \frac{1}{2}$ where $Y = Y(C)$ and $Y' = Y(C')$. The resulting surface X'' is of genus $g + g'$ with a dipole (Q'', χ'') which is determined by (Q, χ) and (Q', χ') . See Chapter 1 of [10] for all details. Figure 2.12 visualizes this construction.

Since D and D' are simply connected it follows that the restrictions of the bundles E and E' to D and D' are trivial. There exists an isomorphism $E|_D \rightarrow E'|_{D'}$ by means of which the bundles can be glued together. The equivalence class of the resulting bundle does not depend on the isomorphism since we have fixed base points for E and E' . More precisely, the trivializations of $E|_D$ and $E'|_{D'}$ are determined by the choice of base points. To

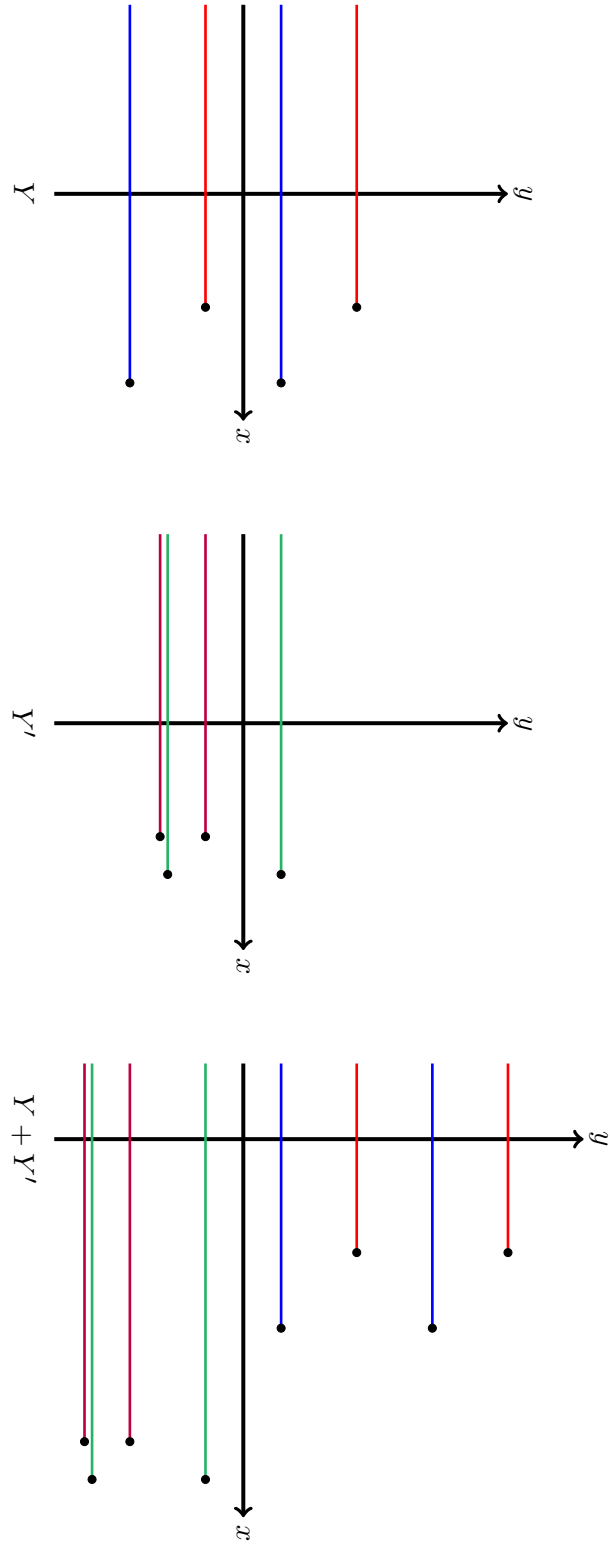

Figure 2.11: Assembling two PSDs with gluing functions

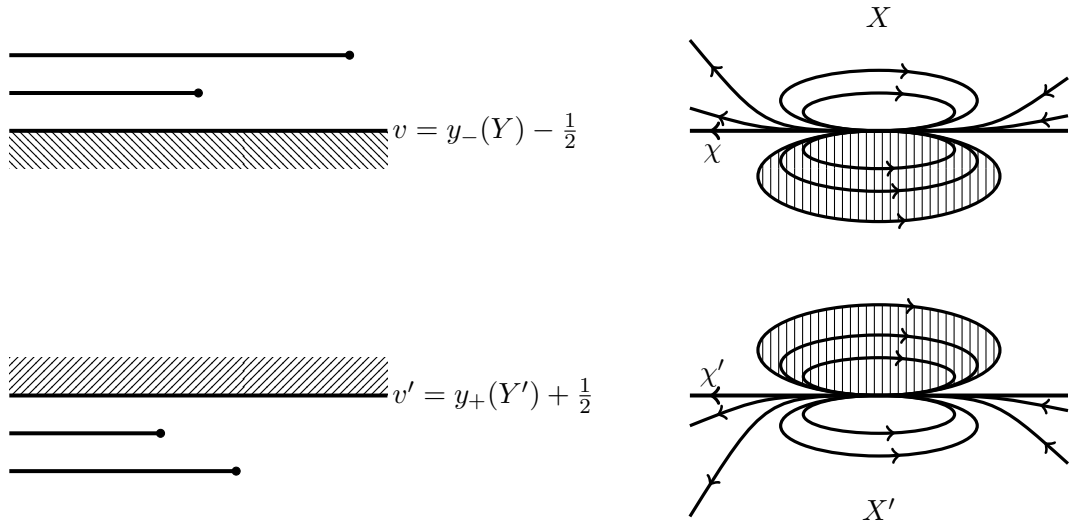

Figure 2.12: Identification along two boundary disks

see this, we describe the construction only for the bundle E since it works for E' by analogy. Denote by X_0 the complement $X - \{Q\}$ and let D_0 be $D - \{Q\}$. The restricted bundle $E|_{X_0}$ is trivial. This follows from the CW-structure of X and that G is a connected Lie group. Thus, there are no obstructions against the triviality of the bundle (see Section 1.2). Any fixed trivializations of $E|_D$ and $E|_{X_0}$ define a transition function $\eta : D_0 \rightarrow G$. Let ς be a generator of $\pi_1(D_0)$ and let η_* be the map induced by η on homotopy groups. Then $\eta_*(\varsigma) \in \pi_1(G)$ is independent of the trivialization of $E|_D$ and $E|_{X_0}$ for the following reason. Changing the trivializations we have maps $h_1 : D \rightarrow G$ and $h_2 : X_0 \rightarrow G$ so that η transforms into the transition function $\eta' = h_2^{-1}\eta h_1$, that is, $\eta'(x) = h_2^{-1}(x)\eta(x)h_1(x)$ in G for all $x \in D_0$. The map $h_1|_{D_0}$ is homotopic to the constant map equal to the identity element $e \in G$ since it extends to a simply connected space. Moreover, the same holds for $h'_2 = h_2|_{D_0}$ since $\pi_1(D_0)$ is in the commutator subgroup of $\pi_1(X_0)$ and $\pi_1(G)$ is abelian. Consequently, $h'_{2*}(\varsigma)$ is trivial. Hence, η' is homotopic to η . Finally, the extension of every such transition function η to Q is defined

by the choice of p_0 . As a consequence, we have induced trivializations which determine the equivalence class of the common glued bundle. In order to prescribe an atlas and a flat connection on this resulting bundle we apply the following more general construction.

Let T_1 and T_2 be two compact manifolds with intersection $T' = T_1 \cap T_2$ and principal G -bundles $p_i : P_i \rightarrow T_i$ for $i = 1, 2$ such that there is an isomorphism $\psi : P_1|_{T'} \rightarrow P_2|_{T'}$. Let $P_1 \dot{\cup} P_2 / \sim =: P_1 \cup_\psi P_2$ be defined so that \sim is the identification of every $y_1 \in P_1|_{T'}$ with $\psi(y_1) \in P_2|_{T'}$. Then $p : P_1 \cup_\psi P_2 \rightarrow T_1 \cup_{T'} T_2 =: T$ is a principal G -bundle. For this we have to show that p is locally trivial. First note, that p is locally trivial for the bundle restricted to $T - T'$ as

$$P_1 \cup_\psi P_2|_{T-T'} \longleftarrow P_1|_{T_1-T'} \dot{\cup} P_2|_{T_2-T'} \xrightarrow{p_1 \dot{\cup} p_2} T - T'.$$

Let $x \in T'$ and Z_1 be a closed, simply connected neighborhood of x in T_1 . Then $p_1|_{Z_1}$ is trivial and so there exists an isomorphism $\theta_1 : P_1|_{Z_1} \rightarrow Z_1 \times G$. We set $\theta'_1 = \theta_1|_{Z_1 \cap T'}$ and $\theta'_2 = \psi \circ \theta'_1$. Since ψ is an isomorphism there is a closed, simply connected neighborhood Z_2 of x in T_2 with an isomorphism $\theta_2 : P_2|_{Z_2} \rightarrow Z_2 \times G$ such that $\theta_2|_{Z_2 \cap T'} = \theta'_2$. Consequently, $\theta_1 \cup_\psi \theta_2$ defines a local isomorphism on $Z_1 \cup Z_2$ so that p is locally trivial. The isomorphism class of $P_1 \cup_\psi P_2$ depends only on the homotopy class of ψ .

As we have seen above there is an isomorphism $E|_D \rightarrow E'_{D'}$ by means of the trivializations at the base points. We obtain a principal G -bundle E'' over X'' from this construction. Moreover, the restricted connections A and A' are trivial on $E|_D$ and $E'_{D'}$ by 1.1.14 and so they agree locally. According to the characterization given by Theorem 1.1.8 the connection forms A and A' fit to a global connection A'' on E'' . The corresponding holonomy representation

$\text{Hol}(A'')$ is exactly the sum of $\text{Hol}(A)$ and $\text{Hol}(A')$ in the sense of Definition 2.5.1.

Lemma 2.5.5. *The operation μ is homotopy associative.*

Proof. Let $C_i \in \mathfrak{P}_{g_i,1}(G)$ and let $Y_i = Y(C_i)$ for $i = 1, 2, 3$. Then the extended PSD $Y_1 + (Y_2 + Y_3)$ is homotopic to $(Y_1 + Y_2) + Y_3$ since it follows from Equations (2.12) and (2.13) that the gluing functions of $(Y_1 + Y_2) + Y_3$ depend only on the order of implantation of each PSD into the complex plane. The same holds for the barycentric coordinates of the associated PSM. Hence, the gluing functions and coordinates of the grid of $(Y_1 + Y_2) + Y_3$ and of $Y_1 + (Y_2 + Y_3)$ are equal to the gluing functions and coordinates of the grid of $Y_1 + Y_2 + Y_3$.

□

Remark 2.5.6. A neutral element for μ is given by the single element of $\mathfrak{P}_{0,1}(G)$ which consists of the empty configuration with no gluing functions for the fiber (see also 2.5.3). We denote this element by $[\emptyset]$ in analogy with Section 1.1 of [10].

The next corollary is implied by Lemma 2.5.5 and Remark 2.5.6.

Corollary 2.5.7. *The space $\mathfrak{P}(G)$ is a homotopy associative disconnected H -space with a homotopy neutral element.*

Corollary 2.5.8. *Let R be a commutative ring with unit. Then μ induces on the homology $H_*(\mathfrak{P}(G); R)$ of $\mathfrak{P}(G)$ with R -coefficients a multiplication which is defined by the composition*

$$H_*(\mathfrak{P}(G)) \otimes H_*(\mathfrak{P}(G)) \xrightarrow{\times} H_*(\mathfrak{P}(G) \times \mathfrak{P}(G)) \xrightarrow{\mu_*} H_*(\mathfrak{P}(G)) \quad (2.14)$$

where $H_*(-; R) = H_*(-)$, \times denotes the exterior homology product and μ_* the map induced by μ on homology.

In view of Corollary 2.5.7, $H_*(\mathfrak{P}(G); R)$ is an associative algebra over R with neutral element. The multiplication defined in (2.14) is called the *Pontryagin product*. In the next step, we will consider a stabilization operation for the spaces $\mathfrak{P}_{g,1}(G)$.

Notation. Let Y^* be the extended PSD given by the following data. The coordinates of the slit ends are $z_s^* = \sqrt{-1}s$ for $1 \leq s \leq 4$, $\tau_1^* = (1, 3)(2, 4)$ and $\gamma_{r,s} = e$ for all $0 \leq r \leq 1$ and $0 \leq s \leq 4$. So Y^* represents the trivial flat G -bundle over the Euclidean torus and we set $C^* = C(Y^*)$.

Definition 2.5.9. Let $\sigma : \mathfrak{P}_{g,1}(G) \rightarrow \mathfrak{P}_{g+1,1}(G)$ be the map defined by $\sigma(C) = \mu(C, C^*)$. Then we define $\mathfrak{P}_\infty(G) = \lim_{\sigma} \mathfrak{P}_{g,1}(G)$.

Proposition 2.5.10. *The following maps are homotopic.*

- (1) $\mu \circ (\sigma \times id) \simeq \sigma \circ \mu$.
- (2) $\mu \circ (id \times \sigma) \simeq \sigma \circ \mu$.
- (3) $\mu \circ (\sigma \times \sigma) \simeq \sigma^2 \circ \mu$.

Proof. First we introduce a meaningful notion of moving some $C \in \mathfrak{P}_{g,1}(G)$ around C^* by moving the respective extended PSDs. We will make this notion precise shortly. Using then the homotopy associativity of μ shown in Lemma 2.5.2 we will obtain homotopies as stated in (1)-(3). We write as usually $C = ((a_i, b_j)_{i,j}, \tilde{\Sigma})$ with $\tilde{\Sigma} = (S_q : \dots : S_0)$ and $S_i = (\gamma_{i,p}, \dots, \gamma_{i,0}; \sigma_i)$ for $S_i \in G \wr \mathfrak{S}_p^0$ where $0 \leq i \leq q$ and $0 \leq j \leq p$. The barycentric coordinates $(a_i, b_j)_{i,j}$ uniquely determine the slit end points z_j for $1 \leq j \leq p$ of $\hat{Y}(C)$. Here $\hat{Y}(C)$ is the region which was constructed in Proposition 2.2.12 from $Y(C)$. By definition of C^* , we have $\sigma_1^* = (0, 3, 2, 1, 4)$ for $\sigma_1^* = \tau_1^* \sigma_0$ where

$\sigma_0 = \omega_4$.

Figuratively speaking, we would like to move the PSD $\hat{Y} = \hat{Y}(C)$ around $\hat{Y}^* = \hat{Y}(C^*)$. To this end, let us introduce the *center* of \hat{Y} by

$$c(\hat{Y}) = \frac{1}{2}(x_+(\hat{Y}) - x_-(\hat{Y})) + \frac{i}{2}(y_+(\hat{Y}) - y_-(\hat{Y})).$$

Then we say that \hat{Y} is *moved* along a path $\omega : I \rightarrow \mathbb{C}$ if $\omega(0) = c(\hat{Y})$ and there is a family of extended PSDs $(\hat{Y}_t)_{t \in I}$ with $\hat{Y}_0 = \hat{Y}$ and $c(\hat{Y}_t) = \omega_t$. By moving the center of \hat{Y} in the plane the end points of the slits are moved appropriately. More precisely, each slit end point z_j of \hat{Y} is moved along $\theta_j \circ \omega$ for an appropriate translation $\theta_j : \mathbb{C} \rightarrow \mathbb{C}$ with $1 \leq j \leq p$. Since the gluing functions stay fixed the notion of moving a PSD is meaningful.

Let $\omega : I \rightarrow \mathbb{C}$ be a continuous closed simple curve through $c(\hat{Y})$ that encloses $c(\hat{Y}^*)$ (see Figure 2.13). We will study the reparameterization of the gluing functions of \hat{Y} when it is moved around \hat{Y}^* along the path ω . For an illustration of the reparameterization of the gluing functions σ_i for $0 \leq i \leq q$ consider Figure 3.3.4 of [10]. Exact calculations were already executed in Sections 3.4 and 3.5 of [10] for G being the trivial group. For this reason, we will focus on the reparameterization of the gluing functions of the fiber $\gamma_{i,j} \in G$ for $0 \leq i \leq q$ and $0 \leq j \leq p$. For the geometric idea see Figure 2.13.

The parallel slit domains are indicated as rectangles of infinite length. Each such rectangle marks the region where all slits are contained. We denote by $R_{i,j}$ the rectangles of $Y(C)$ for $0 \leq i \leq q$ and $0 \leq j \leq p$ and we set $R_{r,s}^*$ for the rectangles of Y^* where $0 \leq r \leq 1$ and $0 \leq s \leq 4$. Now let us move \hat{Y} along ω as depicted in Figure 2.13. We assume that the highest slit of \hat{Y} lies below the highest slit of \hat{Y}^* as shown in the figure. This assumption is

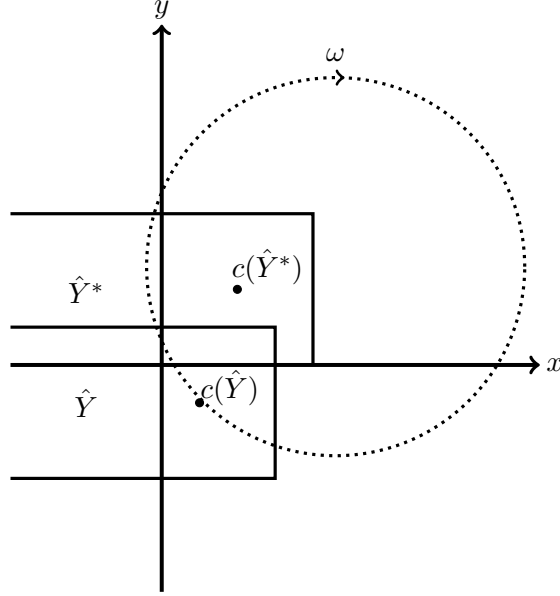

Figure 2.13: Moving \hat{Y} around \hat{Y}^*

just made to simplify the technicalities of the proof. In fact, it will become evident how to change the calculations if the highest slit of \hat{Y} lies above the highest slit of \hat{Y}^* . In this case, we have to describe how \hat{Y} moves along a path around \hat{Y}^* having the opposite orientation as ω .

By assumption, there is a family $(\hat{Y}_t)_{t \in I}$ with $\hat{Y} = \hat{Y}_0$ and $c(\hat{Y}_t) = \omega(t)$. Let $s' \leq 4$ be the smallest number such that there is some $t \in I$ so that \hat{Y}_t intersects rectangles $R_{r,s}^*$ for all $s \leq s'$ and some $r \leq 1$. If \hat{Y}^* and \hat{Y} intersect nontrivially then $t = 0$. When \hat{Y} moves along ω then the upper sides of $R_{i,p}$ pass the upper sides of $R_{r,s'}^*$ for some $i \leq q$ and $r \leq 1$. Then all gluing functions $\gamma_{i,j}$ do not change except possibly $\gamma_{i,\sigma_i(p)}$. More precisely, $\gamma_{i,\sigma_i(p)}$ is transformed to $(\gamma_{r,s'}^*)^{-1} \gamma_{i,\sigma_i(p)}$ if the upper side of $R_{i,p}$ intersects the upper side of $R_{r,s'}^*$. But $\gamma_{r,s'}^* = e$ by definition so that $(\gamma_{r,s'}^*)^{-1} \gamma_{i,\sigma_i(p)} = \gamma_{i,\sigma_i(p)}$. Now we apply this argument inductively to all other rectangles $R_{i,j}$ and gluing functions $\gamma_{i,j}$ of \hat{Y} for $0 \leq i \leq q$ and $0 \leq j \leq p - 1$. Hence, we may deduce that the gluing functions of the fiber for \hat{Y}_t are independent of $t \in I$.

More precisely, they are equal to $(\gamma_{i,j})_{i,j}$. We see that there is a homotopy $F : \mathfrak{P}_{g,1}(G) \times I \rightarrow \mathfrak{P}_{g+1,1}(G)$ such that $F_0 = \mu(C^*, \cdot)$ and $F_1 = \mu(\cdot, C^*)$. This gives the desired homotopies of the proposition as follows. Let $C \in \mathfrak{P}_{g,1}(G)$ and let $C' \in \mathfrak{P}_{g',1}(G)$ then we have

$$\begin{aligned}
(1) \quad & \mu \circ (\sigma \times id)(C, C') = \mu(\sigma(C), C') = \mu(\mu(C, C^*), C') \\
& \stackrel{(ASS)}{\mapsto} \mu(C, \mu(C^*, C')) \mapsto \mu(C, \mu(C', C^*)) \\
& \stackrel{(ASS)}{\mapsto} \mu(\mu(C, C'), C^*) = \sigma \circ \mu(C, C'). \\
(2) \quad & \mu \circ (id \times \sigma)(C, C') = \mu(C, \sigma(C')) = \mu(C, \mu(C', C^*)) \\
& \stackrel{(ASS)}{\mapsto} \mu(\mu(C, C'), C^*) = \sigma \circ \mu(C, C'). \\
(3) \quad & \mu \circ (\sigma \times \sigma)(C, C') = \mu(\mu(C, C^*), \mu(C', C^*)) \stackrel{(ASS)}{\mapsto} \mu(\mu(\mu(C, C^*), C'), C^*) \\
& = \sigma \circ \mu(\mu(C, C^*), C') \stackrel{(ASS)}{\mapsto} \sigma \circ \mu(C, \mu(C^*, C')) \\
& \mapsto \sigma \circ \mu(C, \mu(C', C^*)) \stackrel{(ASS)}{\mapsto} \sigma \circ \mu(\mu(C, C'), C^*) \\
& = \sigma^2 \circ \mu(C, C').
\end{aligned}$$

Here (ASS) means that we apply the associativity of Lemma 2.5.2 while \mapsto without any caption is given by the homotopy F which was constructed above.

□

Corollary 2.5.11. *The space $\mathfrak{P}_\infty(G)$ is an H -space.*

Proof. Using the multiplication μ and Proposition 2.5.10 it follows that there exists a product $\mu_\infty : \mathfrak{P}_\infty(G) \times \mathfrak{P}_\infty(G) \rightarrow \mathfrak{P}_\infty(G)$. The homotopy associativity of μ_∞ is a consequence of Lemma 2.5.2 and Proposition 2.5.10. The neutral element is the infinite limit of the single element in $\mathfrak{P}_{0,1}(G)$.

□

Corollary 2.5.12. *Let R be a commutative ring with unit. Then μ_∞ induces on the homology $H_*(\mathfrak{P}_\infty(G); R)$ of $\mathfrak{P}_\infty(G)$ with R -coefficients a multiplication which is defined by the composition*

$$H_*(\mathfrak{P}_\infty(G)) \otimes H_*(\mathfrak{P}_\infty(G)) \xrightarrow{\times} H_*(\mathfrak{P}_\infty(G) \times \mathfrak{P}_\infty(G)) \xrightarrow{\mu_{\infty,*}} H_*(\mathfrak{P}_\infty(G))$$

where $H_*(-; R) = H_*(-)$, \times denotes the exterior homology product and $\mu_{\infty,*}$ the map induced by μ_∞ on homology.

Chapter 3

Stable moduli spaces of flat G -bundles

3.1 Stabilization of the moduli space of flat G -bundles

In this section we will analyze the homology of $\mathfrak{P}_\infty(G)$ which serves as a model for the stable moduli space of flat G -bundles. To this end, we consider the spaces $\mathcal{S}_{g,n,\partial}(BG)$ which were introduced in [18]. These are defined by continuous maps from surfaces with certain boundary conditions to BG , the so-called *background space*. The homology of $\mathcal{S}_{g,n,\partial}(BG)$ stabilizes for $g \gg 0$ in the same vein as Harer stability, see [18] and [19]. For this reason, these spaces are more convenient for the questions we address in this section than the space of parallel slit domains which we considered in the previous chapter. The spaces $\mathcal{S}_{g,n,\partial}(BG)$ are defined for oriented, connected, compact surfaces of genus $g \geq 0$ with $n \geq 0$ boundary components. The relationship between surfaces with boundary components in contrast to surfaces with dipole points was made precise in Section 1.5. In fact, we will see that the

moduli space of flat, pointed G -bundles over a Riemann surface of genus g with one boundary component and certain fixed boundary conditions is homotopy equivalent to the moduli space of flat, pointed G -bundles over a Riemann surface of genus g with one dipole point. In the first part of this section we will relate our work to other developments on the parameterization question of flat G -bundles over Riemann surfaces. The second part is devoted to an explicit construction of the Dyer–Lashof operations of $\mathfrak{P}_\infty(G)$.

We assume for the rest of this section that G is a connected and compact Lie group if not specified otherwise.

Definition 3.1.1 ([18]). Let G be a connected and compact Lie group and let $\lambda : \coprod_n S^1 \rightarrow BG$ be a continuous map. The space $\mathcal{S}_{g,n,\lambda}(BG)$ consists of orientation preserving diffeomorphism classes of quadruples $(F, (a, b), \varphi, f)$ where $(a, b) \in \mathbb{R}^2$ with $a \leq b$ and F is a smooth, oriented surface of topological type $F_{g,n}$ embedded neatly in $\mathbb{R}^\infty \times [a, b]$ such that its boundary $\partial F \subseteq \mathbb{R}^\infty \times \{a\} \cup \mathbb{R}^\infty \times \{b\}$. Further, $\varphi : \coprod_n S^1 \rightarrow \partial F$ is a parameterization (an orientation preserving diffeomorphism) of the boundary and $f : F \rightarrow BG$ is a continuous map with $f|_{\partial F} \circ \varphi = \lambda$. We denote an element of $\mathcal{S}_{g,n,\lambda}(BG)$ by $[F, (a, b), \varphi, f]$.

For the definition of a *neat* embedding we suggest Section 1.4 of [31]. If the boundary of the surface F is not empty then we set $\partial_{in}F$ for $\partial F \cap (\mathbb{R}^\infty \times \{a\})$ and $\partial_{out}F$ for the boundary components $\partial F \cap (\mathbb{R}^\infty \times \{b\})$. Further, the connected components of ∂F are labeled by $\partial_0F, \dots, \partial_{n-1}F$ such that ∂_0F is contained in $\partial_{in}F$. In Definition 3.1.1 the boundary components admit two orientations. Indeed, one is induced by the orientation of the surface while the second is given by the parameterization φ . These two orientations agree on $\partial_{out}F$ and disagree on $\partial_{in}F$.

The topology of $\mathcal{S}_{g,n,\lambda}(BG)$ is given by the following description. Let X be a

fixed surface of genus g with n boundary components and let $\eta : \coprod_n S^1 \rightarrow \partial X$ be a fixed parameterization of the boundary of X . The space $\mathcal{E}(X, \mathbb{R}^\infty)$ of embeddings of X into $\mathbb{R}^\infty \times [a, b]$ (cf. Definition 3.1.1) equipped with the compact-open topology is contractible (see e.g. Section 15 of [45] for a proof). Moreover, $\mathcal{E}(X, \mathbb{R}^\infty)$ possesses a free action of $Diff_\partial(X)$ by composition. Here we denote by $Diff_\partial(X)$ the group of orientation preserving diffeomorphisms of X fixing the boundary components pointwise. Let $\mathfrak{Map}_\lambda(X, BG)$ be the space of continuous maps $h : X \rightarrow BG$ satisfying $h|_{\partial X} \circ \eta = \lambda$ equipped with the compact-open topology. The group $Diff_\partial(X)$ acts by composition on $\mathfrak{Map}_\lambda(X, BG)$. We see that $\mathcal{S}_{g,n,\lambda}(BG)$ is as a set in one-to-one correspondence with $\mathbb{R} \times \mathbb{R}_0^+ \times \mathcal{E}(F_{g,n}, \mathbb{R}^\infty) \times_{Diff_{g,n}} \mathfrak{Map}_\lambda(F_{g,n}, BG)$ by mapping a class $[X, (a, b), \eta, h]$ to $((a, b - a), [X, \eta, h])$. So $\mathcal{S}_{g,n,\lambda}(BG)$ will be topologized by means of this bijection. Since the action of $Diff_{g,n}$ on $\mathcal{E}(F_{g,n}, \mathbb{R}^\infty)$ is free the fiber product $EDiff_{g,n} \times_{Diff_{g,n}} \mathfrak{Map}_\lambda(F_{g,n}, BG)$ is homotopy equivalent to $\mathcal{S}_{g,n,\lambda}(BG)$.

We are interested in studying the homotopy type of $\mathcal{S}_{g,n,\lambda}(BG)$. To this end, let $\mathcal{S}_{g,n}(BG)$ be the moduli space which is analogously defined as $\mathcal{S}_{g,n,\lambda}(BG)$ but where the boundary conditions are omitted. Let LM be the *free loop space* of a space M , that is, $LM = \mathfrak{Map}(S^1, M)$. The fiber of the evaluation map (restriction to the boundary) $\mathcal{S}_{g,n}(BG) \rightarrow (LBG)^n$ over $\lambda = (\lambda_0, \dots, \lambda_{n-1})$ is $\mathcal{S}_{g,n,\lambda}(BG)$ for every $\lambda \in (LBG)^n$. As G is connected by assumption, its classifying space is simply connected and LBG is connected. Consequently, the homotopy type of $\mathcal{S}_{g,n,\lambda}(BG)$ does not depend on $\lambda \in (LBG)^n$. We denote by $\mathcal{S}_{g,n,\partial}(BG)$ the space $\mathcal{S}_{g,n,\lambda}(BG)$ for λ the constant loops equal to the base point $p_0 \in BG$. Then $\mathcal{S}_{g,n,\partial}(BG)$ is homotopy equivalent to $EDiff_{g,n} \times_{Diff_{g,n}} \mathfrak{Map}_\partial(F_{g,n}, BG)$ where $\mathfrak{Map}_\partial(F_{g,n}, BG)$ is the space of all continuous maps $f : F_{g,n} \rightarrow BG$ such that $f|_{\partial F_{g,n}} = p_0$. It

is equipped with the compact-open topology.

Definition 3.1.2. For a compact surface X let $\mathfrak{Map}_*(X, BG)$ denote the mapping space of pointed maps from X to BG . Then the *classifying map* $B : \mathcal{R}_G(X) \rightarrow \mathfrak{Map}_*(B\pi_1(X), BG)$ is defined as the adjoint of the quotient map of $\mathcal{R}_G(X) \times \coprod_{\alpha \geq 0} \pi_1(X)^\alpha \times \Delta^\alpha \rightarrow \coprod_{\alpha \geq 0} G^\alpha \times \Delta^\alpha$.

Note that the classifying map is continuous by definition of the compact-open topology on $\mathcal{R}_G(X)$. For further details on adjoint maps and the geometric realization see Section 16 of [41].

Let G be a compact, connected and semisimple Lie group and $g \geq 2$. Then there exists a map $\mathcal{V}(G) : \mathcal{M}_{g,1}(G) \rightarrow \mathcal{S}_{g,1}(BG)$ which is k -connected for some $k = k(g, G)$. It is defined by the classifying map B from Definition 3.1.2 in conjunction with Lemma 1.2.8:

$$\begin{array}{ccc}
\mathcal{M}_{g,1}(G) & \xrightarrow{\mathcal{V}(G)} & \mathcal{S}_{g,1}(BG) \\
\cong \downarrow & & \downarrow \cong \\
EDiff_{g,1} \times_{Diff_{g,1}} \mathcal{R}_G(S_{g,1}) & \longrightarrow & EDiff_{g,1} \times_{Diff_{g,1}} \mathfrak{Map}_*(B\pi_1(S_{g,1}), BG).
\end{array} \tag{3.1}$$

The number k was first introduced in [5] and made precise in [17]. We will examine this map in more detail in the next section using methods from [5]. Moreover, the preimage of $\mathcal{S}_{g,1,\partial}(BG)$ in $\mathcal{M}_{g,1}(G)$ under $\mathcal{V}(G)$ is denoted by $\mathcal{M}_{g,1,\partial}(G)$. Using the homotopy equivalence (3) in Theorem 2.3.7 we will analogously consider the component $\mathfrak{P}_{g,1,\partial}(G)$ of $\mathfrak{P}_{g,1}(G)$, that is, the preimage of $\mathcal{M}_{g,1,\partial}(G)$ under $\mathfrak{p}(G) \circ \mathcal{H}(G)$.

The connected components of $\mathcal{M}_{g,1}(G)$ and $\mathcal{S}_{g,1}(BG)$ are in one-to-one correspondence with $\pi_1(G)$. This statement was discussed in Section 1.2 for $\pi_0(\mathcal{M}_{g,1}(G))$. To see this for $\mathcal{S}_{g,1}(BG)$, let $[X, (a, b), \varphi, f]$ be an element of $\mathcal{S}_{g,1}(BG)$. We denote by $[X]$ the orientation class of the surface X . Then

$f_*([X]) \in H_2(BG)$ where f_* is the map on homology induced by f . As BG is simply connected there is an isomorphism $H_2(BG) \cong \pi_1(G)$ such that $f_*([X])$ can be considered as an element of $\pi_1(G)$. For further details see [17]. Note that it was shown in Section 6 of [38] that the classifying map respects these connected components so that B induces a bijection between $\pi_0(\mathcal{M}_{g,1}(G))$ and $\pi_0(\mathcal{S}_{g,1}(BG))$. See also Section 2.2 of [17] on this point. Next we will examine the stable homotopy type of $\mathcal{S}_{g,1,\partial}(BG)$. In [18] and [19] it was shown that the following maps induce homological stability for $\mathcal{S}_{g,1,\partial}(BG)$ if $g \gg 0$.

Definition 3.1.3. Let G be a connected and compact Lie group. We fix a base point $p_0 \in BG$. Moreover, for $n \geq 1$ let $[X, (a, b), \varphi, f] \in \mathcal{S}_{g,n,\partial}(BG)$ be given.

(SM1) Let $T \subseteq \mathbb{R}^3 \times [0, 1] \subseteq \mathbb{R}^\infty \times [0, 1]$ be a torus with two boundary components $\partial_{in}T = \partial_0T$ and $\partial_{out}T = \partial_1T$. By Definition 3.1.1, X is embedded in $\mathbb{R}^\infty \times [a, b]$ for a closed interval $[a, b]$. We translate T so that it is embedded in $\mathbb{R}^\infty \times [a - 1, a]$. Then we identify ∂_1T with ∂_0X by means of the fixed parameterization. For each boundary component of $\partial_{in}X$ other than ∂_0X we glue in a cylinder $S^1 \times [a - 1, a]$ using the given parameterization. The resulting surface is of genus $g + 1$ with n boundary components and is embedded in $\mathbb{R}^\infty \times [a - 1, b]$. The given parameterization of ∂X induces a parameterization of the boundary of the resulting surface. The map $f : X \rightarrow BG$ can be continuously extended to T and the cylinders by the constant mapping to the base point which we denote by p_0 . Hence there is a map

$$T_G : \mathcal{S}_{g,n,\partial}(BG) \longrightarrow \mathcal{S}_{g+1,n,\partial}(BG).$$

(SM2) Let $P \subseteq \mathbb{R}^3 \times [0, 1] \subseteq \mathbb{R}^\infty \times [0, 1]$ be a sphere with three boundary components such that $\partial_{in}P = \partial_0P \cup \partial_1P$ and $\partial_{out}P = \partial_2P$. We translate P so that it is embedded in $\mathbb{R}^\infty \times [a - 1, a]$. Then we identify ∂_2P with ∂_0X by means of the fixed parameterization. For the other boundary components of $\partial_{in}X$ we proceed as in (SM1). Consequently, as in (SM1) there is a map

$$P_G : \mathcal{S}_{g,n,\partial}(BG) \longrightarrow \mathcal{S}_{g,n+1,\partial}(BG).$$

(SM3) Let D be a disk D^2 embedded in $\mathbb{R}^\infty \times [0, 2]$ such that $\partial D \in \mathbb{R}^\infty \times \{0\}$. We translate D so that it is embedded in $\mathbb{R}^\infty \times [b, b + 2]$. Then we identify $\partial_{n-1}X$ with ∂D by means of the fixed parameterization. For all other boundary components of $\partial_{out}X$ we glue in a cylinder $S^1 \times [b, b + 1]$. Analogously to (SM1) and (SM2) there exists a map

$$D_G : \mathcal{S}_{g,n,\partial}(BG) \longrightarrow \mathcal{S}_{g,n-1,\partial}(BG).$$

Note that the maps of Definition 3.1.3 are continuous. To this end, we assumed in Definition 3.1.1 that the surfaces are neatly embedded in the Euclidean space. Then we have collars of the surfaces' boundary components to reglue them along the boundary as described in (SM1)-(SM3). For details on the collar construction see Section 8.2 of [31]. For the maps of Definition 3.1.3, the following central theorem was shown in [18] and [19].

Theorem 3.1.4. *The induced maps on homology $H_q(T_G)$, $H_q(S_G)$ and $H_q(D_G)$ are isomorphisms for $2q + 4 \leq g$.*

This theorem which is a generalization of Harer's stability theorem is quite surprising. On the one hand side, we previously mentioned that

$EDiff_{g,n} \times_{Diff_{g,n}} \mathfrak{Map}_\partial(F_{g,n}, BG)$ is homotopy equivalent to $\mathcal{S}_{g,n,\partial}(BG)$. So we have the fibration $\mathfrak{Map}_\partial(F_{g,n}, BG) \rightarrow \mathcal{S}_{g,n,\partial}(BG) \rightarrow BDiff_{g,n}$. The homology of $BDiff_{g,n} \cong B\Gamma_{g,n}$ is independent of g and n for $g \gg 0$. On the other hand, this does not hold for the homology of $\mathfrak{Map}_\partial(F_{g,n}, BG)$. The reason for this ambiguity is that the mapping class group acts nontrivially on the homology of $\mathfrak{Map}_\partial(F_{g,n}, BG)$. For further details we refer to [18] and [19]. Now let $\mathcal{S}_{\infty,n,\partial}(BG) = \mathop{hocolim}_{T_G} \mathcal{S}_{g,n,\partial}(BG)$ be the homotopy limit defined by T_G .

Theorem 3.1.5 ([18]). *Let G be a connected and compact Lie group, then there is a homology equivalence $\mathbb{Z} \times \mathcal{S}_{\infty,n,\partial}(BG) \rightarrow \Omega^\infty(\mathbb{C}P_{-1}^\infty \wedge BG_+)$ on integral homology.*

The spectrum $\mathbb{C}P_{-1}^\infty$ is the Madsen–Weiss spectrum (see [40] for its construction). Using the map $\mathcal{V}(G) : \mathcal{M}_{g,1}(G) \rightarrow \mathcal{S}_{g,1}(BG)$ and Theorem 3.1.5 from [18] and [19] we obtain the following corollary for $\mathfrak{P}_{\infty,\partial}(G) = \mathop{hocolim}_\sigma \mathfrak{P}_{g,1,\partial}$.

Corollary 3.1.6. *Let G be a connected, compact and semisimple Lie group. Then $H_q(\mathfrak{P}_{g,1}(G))$ does not depend on g for $2q + 4 \leq g$. Moreover, there is a homology equivalence $\mathbb{Z} \times \mathfrak{P}_{\infty,\partial}(G) \rightarrow \Omega^\infty(\mathbb{C}P_{-1}^\infty \wedge BG_+)$ on integral homology.*

Proof. Applying Theorem 3.1.5 it remains to show that the diagram

$$\begin{array}{ccccc} \mathfrak{P}_{g,1,\partial}(G) & \xrightarrow{\mathcal{U}(G)} & \mathcal{M}_{g,1,\partial}(G) & \xrightarrow{\mathcal{V}(G)} & \mathcal{S}_{g,1,\partial}(BG) \\ \sigma \downarrow & & \downarrow \hat{\sigma} & & \downarrow T_G \\ \mathfrak{P}_{g+1,1,\partial}(G) & \xrightarrow{\mathcal{U}(G)} & \mathcal{M}_{g+1,1,\partial}(G) & \xrightarrow{\mathcal{V}(G)} & \mathcal{S}_{g+1,1,\partial}(G) \end{array} \quad (3.2)$$

commutes up to homotopy. Here we denote by $\mathcal{U}(G)$ the composition

$$\mathfrak{P}_{g,1,\partial}(G) \xrightarrow{\mathcal{H}(G)} \mathfrak{H}_{g,1,\partial}(G) \xrightarrow{\mathfrak{P}(G)} \mathcal{M}_{g,1,\partial}(G).$$

The map $\hat{\sigma}$ is defined by gluing the trivial flat G -bundle over the torus $(\epsilon, \pi_\epsilon, T, A_\epsilon)$ to each representative (E, π, X, A) of an element from $\mathcal{M}_{g,1}(G)$. This kind of gluing construction was carried out in Section 2.5. Finally, the space $\mathfrak{H}_{g,1,\partial}(G)$ is the image $\mathcal{H}(G)(\mathfrak{P}_{g,1,\partial}(G))$. For $C \in \mathfrak{P}_{g,1,\partial}(G)$ we have

$$\begin{aligned}\hat{\sigma} \circ \mathcal{U}(G)(C) &= \hat{\sigma} \circ \mathfrak{p}(G) \circ \mathcal{H}(G)(C) = \hat{\sigma} \circ \mathfrak{p}(G)([E, \pi, X, A, u]) \\ &= \hat{\sigma}([E, \pi, X, A]) = [E\#\epsilon, \hat{\pi}, X\#T, \hat{A}]\end{aligned}$$

where $\hat{\pi}$ is the bundle projection $E\#\epsilon \rightarrow X\#T$ and \hat{A} is the reglued flat connection form from A and A_ϵ . On the other hand,

$$\mathcal{U}(G) \circ \sigma(C) = \mathcal{U}(G)(\mu(C, C^*)) = \mathfrak{p}(G) \circ \mathcal{H}(G)(\mu(C, C^*)) = [E\#\epsilon, \hat{\pi}, X\#T, \hat{A}]$$

by the gluing construction of Section 2.5. It follows that the left square of Diagram (3.2) commutes.

Next we show the commutativity of the right square up to homotopy. Let $[E, \pi, X, A]$ be from $\mathcal{M}_{g,1}(G)$ and let ρ_A be the holonomy representation to A . We denote by $f : X \rightarrow BG$ the classifying map of the principal bundle $\pi : E \rightarrow X$. Then $\mathcal{V}(G) \circ \hat{\sigma}([E, \pi, X, A]) = \mathcal{V}(G)([E\#\epsilon, \hat{\pi}, X\#T, \hat{A}])$ and $\rho_{\hat{A}} = \mathfrak{m}(\rho_A, \rho_0)$. So $\mathcal{V}(G)([E\#\epsilon, \hat{\pi}, X\#T, \hat{A}]) = [X\#T, (0, b'), f', \varphi']$ where $b' > 0$ is determined by the conformal structure of X (by definition of $\mathcal{V}(G)$ in Equation (3.1)). Moreover, $f' : X\#T \rightarrow BG$ is the classifying map of the bundle $E\#\epsilon$. Since ϵ is trivial the restriction of f' to T is homotopic to the constant value $p_0 \in BG$ and so $f' \simeq f\#p_0$. Further, φ' is a parameterization of the boundary given by $f'|_{\partial(X\#T)} \circ \varphi' = p_0$. On the other hand,

$$T_G \circ \mathcal{V}(G)([E, \pi, X, A]) = T_G([X, (0, b), f, \varphi]) = [X\#T, (-1, b), f', \varphi']$$

where $f' \simeq f \# p_0$ and φ is given by the equation $f|_{\partial(X \# T)} \circ \varphi = p_0$. Moreover, φ' is determined by φ as described in (SM1). We have $b = b' - 1$ that is determined by the conformal structure of X . Thus, the right square commutes up to homotopy.

□

Theorem 3.1.5 of [18] shows that $\mathcal{S}_{\infty, n, \partial}(BG)$ is homology equivalent to an infinite loop space. The proof applies methods which were developed in [50]. Next, we will prove using different techniques that the group completion of $\mathcal{S}_{\infty, n, \partial}(BG)$ is weakly homotopy equivalent to an infinite loop space. One might expect that the two loop space structures agree since this was verified in [54] for G being the trivial group. The proof could carry over to the general case. The advantage of this second method is the natural explicit construction of the Dyer–Lashof operations. The main idea which was introduced in [51] is that the operad of Riemann surfaces (see Example 3.1.9) detects infinite loop spaces. More precisely, in analogy with the recognition principle of [42], for a group completion of a space to be an infinite loop space it has to be checked that the operad of Riemann surfaces \mathcal{M} (see Example 3.1.9) acts upon it. To this purpose, we introduce briefly the theory of topological monoids. A detailed discussion of this topic is for instance contained in [2]. Let M be a topological monoid for which we always assume that it is a strictly associative CW-complex with a two-sided strict unit. Its classifying space BM is defined as the geometric realization of the bar construction associated with M . See for instance Section 2.5 of [2] for more details. There exists an inclusion from the suspension of M into the classifying space BM whose adjoint defines a map $j : M \rightarrow \Omega BM$. Further, j is a homotopy equivalence if $\pi_0(M)$ is a group. For example, this condition is satisfied for every topological group. We call a map $f : M \rightarrow N$ between two topological monoids a

group completion if $\pi_0(f)$ is an algebraic completion, that is, $\pi_0(N)$ is abelian and universal with respect to maps from $\pi_0(M)$ to homotopy groups given by morphisms of monoids. Moreover, $f_* : H_*(M) \rightarrow H_*(N)$ is the localization of $H_*(M)$ at $\pi_0(M)$. The monoid N is characterized uniquely up to homotopy (see Section 3.2 of [2]). We denote it by $\mathcal{G}M$ and call it also the *group completion* of M . This notation is motivated by the fact that every discrete monoid possesses a group completion, the so-called *Grothendieck construction*. It can be constructed as the quotient of the free group on M and the subgroup generated by elements $m_1 * m_2 * m_3^{-1}$ such that $m_1 m_2 = m_3$. Here $*$ denotes the concatenation in the free group on M . For instance, $\mathcal{G}\mathbb{N} = \mathbb{Z}$. Morally, ΩBM can be considered as a topological generalization of the algebraic Grothendieck construction since for topological monoids we have $\pi_0(\Omega BM) = \mathcal{G}\pi_0(M)$.

Now let $M = \coprod_{\alpha} M_{\alpha}$ be a disconnected monoid with connected components M_{α} . Note that ΩBM splits as $\pi_0(\Omega BM) \times \Omega_0 BM$ where Ω_0 denotes the component of the constant loop. The induced map $j_* : \pi_0(M) \rightarrow \pi_0(\Omega BM)$ defines a map $M_{\alpha} \rightarrow \Omega BM_{j_*(\alpha)}$. Multiplication by α in $\pi_0(M)$ defines a map $\alpha : M_{\beta} \rightarrow M_{\alpha\beta}$. Hence, we obtain the commutative diagram

$$\begin{array}{ccc} H_*(M_{\beta}) & \longrightarrow & H_*(M_{\alpha\beta}) \\ \downarrow & & \downarrow \\ H_*(\Omega BM_{j_*(\beta)}) & \longrightarrow & H_*(\Omega BM_{j_*(\alpha\beta)}). \end{array}$$

For the homotopy colimit M_{∞} of $\{M_{\alpha}\}_{\alpha \in \pi_0(M)}$ the following theorem from [44] is satisfied.

Theorem 3.1.7 ([44]). *Let M be a topological monoid for which left multiplication by any element defines an isomorphism on $H_*(M_{\infty})$. Then there is*

an isomorphism $\operatorname{hocolim}_{\alpha \in \pi_0(M)} H_*(M_\alpha) \rightarrow H_*(\Omega_0 BM)$.

Assume that $M = \coprod_{n \geq 0} M_n$ is the disjoint union of connected components labeled by $n \geq 0$ and that multiplication with an element from M_1 takes M_n to M_{n+1} as above. Let M_∞ be the homotopy colimit with respect to $n \rightarrow \infty$. As $\pi_0(M) = \mathbb{N}$ and $\pi_0(\Omega BM)$ is a group completion, the components of ΩBM are indexed by \mathbb{Z} . By the previous theorem M_∞ is homology equivalent to $\Omega_0 BM$. Consequently, there is a homology equivalence $\mathbb{Z} \times M_\infty \rightarrow \Omega BM$.

Note that in general two homology equivalent spaces are not automatically homotopy equivalent. On the other hand, by means of the so-called *plus construction* due to Quillen the homotopy groups of $\mathbb{Z} \times M_\infty$ and ΩBM can be related. The plus construction can be applied to topological spaces Y if its fundamental group possesses a perfect normal subgroup P . The latter determines a number of 2-cells and 3-cells to be glued into Y from which a space Y^+ can be constructed such that there is a homology equivalence $Y \rightarrow Y^+$ and $\pi_1(Y^+)$ is abelian. The topological space Y^+ is called the *plus construction* of Y .

After this foundational material on monoids we will give a brief introduction on operads, for these are important objects to study stability phenomena in algebraic topology.

Definition 3.1.8. An *operad* \mathcal{O} is a sequence of topological spaces $\{\mathcal{O}_n\}_{n \geq 0}$ with distinguished elements $\mathbb{1} \in \mathcal{O}_1$ and $*$ $\in \mathcal{O}_0$ such that for every $n \geq 0$ there is a right action of the symmetric group \mathfrak{S}_n on \mathcal{O}_n . Moreover, for all $k \geq 1$, $j_\alpha \geq 0$ and $1 \leq \alpha \leq k$ there exists a *product map*

$$\gamma : \mathcal{O}_k \times \mathcal{O}_{j_1} \times \dots \times \mathcal{O}_{j_k} \longrightarrow \mathcal{O}_{j_1 + \dots + j_k}$$

such that the following properties are satisfied.

(O1) For all $k \geq 1$, $1 \leq \alpha \leq k$, $a \in \mathcal{O}_k$, $b_\alpha \in \mathcal{O}_\alpha$ and $c_{i_\beta} \in \mathcal{O}_{i_\beta}$ we have

$$\gamma(\gamma(a; b_1, \dots, b_k), c_1, \dots, c_j) = \gamma(a; d_1, \dots, d_k)$$

where $j = j_1 + \dots + j_k$, $d_\alpha = \gamma(b_\alpha; c_{j_1+\dots+j_{\alpha-1}+1}, \dots, c_{j_1+\dots+j_\alpha})$ and $d_\alpha = c_\alpha$ if $j_\alpha = 0$.

(O2) For all $a \in \mathcal{O}_k$ and $b \in \mathcal{O}_j$ we have $\gamma(\mathbf{1}; b) = b$ and $\gamma(a; \underbrace{\mathbf{1}, \dots, \mathbf{1}}_{k\text{-fold}}) = a$.

(O3) For all $a \in \mathcal{O}_k$, $b_\alpha \in \mathcal{O}_{j_\alpha}$, $\sigma \in \mathfrak{S}_k$ and $\tau_\alpha \in \mathfrak{S}_{j_\alpha}$ we have

$$\begin{aligned} \gamma(c.\sigma; b_1, \dots, b_k) &= \gamma(c; b_{\sigma^{-1}(1)}, \dots, b_{\sigma^{-1}(k)}).\sigma(j_1, \dots, j_k) \\ \gamma(c; b_1.\tau_1, \dots, b_k.\tau_k) &= \gamma(c; b_1, \dots, b_k).(\tau_1 \oplus \dots \oplus \tau_k), \end{aligned}$$

where $\sigma(j_1, \dots, j_k) \in \mathfrak{S}_{j_1+\dots+j_k}$ permutes $j_1 + \dots + j_k$ blocks of the size j_α by means of σ , and $\tau_1 \oplus \dots \oplus \tau_k$ corresponds to the image of (τ_1, \dots, τ_k) under the natural inclusion $\mathfrak{S}_{j_1} \times \dots \times \mathfrak{S}_{j_k} \rightarrow \mathfrak{S}_{j_1+\dots+j_k}$.

An important example of an operad is the operad of Riemann surfaces \mathcal{M} which we present next. It will be used to detect infinite loop spaces. We just sketch the construction of \mathcal{M} briefly. We suggest [51] for all further details.

Example 3.1.9 ([51]). Analogous to Definition 3.1.3 we pick three surfaces, that is, the torus T with two boundary components, a pair-of-pants \hat{P} and a disc D . For T , \hat{P} and D we fix collars of the boundary components. Moreover, we assume that $\partial_{in}T$ as well as $\partial_{out}T$ are nonempty and that $\partial_{out}\hat{P}$ consists of two components. We construct a connected *groupoid* $\mathcal{E}_{g,n,1}$ (a category where every morphism is invertible) as follows. The objects of $\mathcal{E}_{g,n,1}$ are pairs (F, η) where F is a surface of topological type $F_{g,n+1}$ with fixed collars of its boundary and η is a parameterization of ∂F which agrees with the collars on the boundary. Further, F is manufactured from T , \hat{P} and D

by gluing the boundary ∂_0 of one of these surfaces to ∂_{out} of another of these surfaces using the given parameterizations. Note that then $\partial_{in}F = \partial_0F$ and $\partial_{out}F$ consists of $\partial_1F, \dots, \partial_nF$. The set of morphisms $\Gamma(F, F')$ between (F, η) and (F', η') are homotopy classes of orientation preserving diffeomorphisms which preserve the parameterizations and the boundary components pointwise. By permuting the index set of the n boundary components of $\partial_{out}F$ there is an action of \mathfrak{S}_n on $\mathcal{E}_{g,n,1}$. Moreover, the classifying space $B\mathcal{E}_{g,n,1}$ is homotopy equivalent to $B\Gamma_{g,n+1}$ (see [51]).

The gluing of surfaces along boundary components as described before induces associative and \mathfrak{S} -equivariant maps of categories which determine the following maps of classifying spaces:

$$\gamma : B\mathcal{E}_{g,k,1} \times B\mathcal{E}_{g_1,n_1,1} \times \dots \times B\mathcal{E}_{g_k,n_k,1} \longrightarrow B\mathcal{E}_{g+g_1+\dots+g_k,n_1+\dots+n_k,1}.$$

The maps γ are associative and \mathfrak{S} -equivariant. Unfortunately, the spaces $\coprod_{g \geq 0} B\mathcal{E}_{g,n,1}$ do not form an operad for there is no unit element ((O2) is not satisfied). In order to obtain an operadic structure we have to divide by two relations.

To this end, let $\psi_1 : \gamma(\hat{P}; D, \cdot) \rightarrow \gamma(\hat{P}; \cdot, D)$ and $\psi_2 : \gamma(\hat{P}; \cdot, \hat{P}) \rightarrow \gamma(\hat{P}; \hat{P}, \cdot)$ be two isotopies relative to the collars. We say that two surfaces are equivalent if there is an isotopy between them defined by the composition of ψ_1 , ψ_2 or their inverses on the constituting subsurfaces. Then there is a unique representative F_0 in each such equivalence class containing no subsurfaces of type $\gamma(\hat{P}; D, \cdot)$ or $\gamma(\hat{P}; \cdot, \hat{P})$. Moreover, ψ_1 and ψ_2 define an isotopy $\psi_F : F \rightarrow F_0$ for every F lying in the equivalence class of F_0 . We define structure maps γ_0 on objects by taking the unique representative of the image of γ . On morphisms we have $\gamma_0(h; h_1, \dots, h_k) = \psi_{F'}\gamma(h; h_1, \dots, h_k)\psi_F^{-1}$

where F and F' are in the source and the target of the maps h , respectively. Furthermore, let $\psi : \gamma(\hat{P}; \cdot, D) \rightarrow S^1 \times [0, 1] \rightarrow S^1$ be the composition of an isotopy relative to the collar followed by the projection on the first factor. For every surface F let \hat{F} be the surface which results from F by replacing every subsurface of the form $\gamma(\hat{P}; \cdot, D)$ by S^1 . This is realized with a homotopy $F \rightarrow \hat{F}$ defined by means of ψ . We identify $\Gamma(F, F')$ with $\Gamma(\hat{F}, \hat{F}')$ using such homotopies $F \rightarrow \hat{F}$ and $F' \rightarrow \hat{F}'$. Let $\hat{\mathcal{E}}_{g,n,1}$ be the category after quotienting $\mathcal{E}_{g,n,1}$ with respect to these two equivalence relations (induced by ψ_1, ψ_2 and ψ). The maps γ_0 define structure maps $\hat{\gamma}_0$ for $\hat{\mathcal{E}}_{g,n,1}$. Note that $\hat{\gamma}_0$ has now a unit element which is given by the single object S^1 in $\hat{\mathcal{E}}_{0,1,1}$. We denote the disjoint union of the classifying spaces $\coprod_{g \geq 0} B\hat{\mathcal{E}}_{g,n,1}$ by \mathcal{M}_n . It was shown in [51] that $\{\mathcal{M}_n\}_{n \geq 0}$ forms an operad with structure maps defined by $\hat{\gamma}_0$. In particular, \mathcal{M}_n is homotopy equivalent to $\coprod_{g \geq 0} B\Gamma_{g,n+1}$ for all $n \geq 0$.

Definition 3.1.10. For an operad \mathcal{O} , a pointed space (X, x_*) is called an \mathcal{O} -space or we say that an operad \mathcal{O} acts on (X, x_*) if for all $k \geq 0$ there are so-called *structure maps* $\vartheta : \mathcal{O}_k \times X^k \rightarrow X$ such that the following conditions are satisfied.

(OS1) For all $a_k \in \mathcal{O}_k, b_\alpha \in \mathcal{O}_{j_\alpha}$ and $x_i \in X$ with $j = j_1 + \dots + j_k$ we have

$$\vartheta(\gamma(a; b_1, \dots, b_k); x_1, \dots, x_j) = \vartheta(a; \bar{x}_1, \dots, \bar{x}_k)$$

while $\bar{x}_\alpha = \vartheta(b_\alpha; x_{j_1+\dots+j_{\alpha-1}+1}, \dots, x_{j_1+\dots+j_\alpha})$ for $1 \leq \alpha \leq k$.

(OS2) For all $x \in X$ we have $\vartheta(\mathbb{1}; x) = x$ and $\vartheta(*; x_*) = x_*$.

(OS3) For all $a \in \mathcal{O}_k, x_\alpha \in X$ and $\sigma \in \mathfrak{S}_k$ we have

$$\vartheta(a.\sigma; x_1, \dots, x_k) = \vartheta(a; x_{\sigma^{-1}(1)}, \dots, x_{\sigma^{-1}(k)}).$$

Notation. For an operad \mathcal{O} and a pointed space (X, x_*) we set $\mathcal{O}(X)$ for $\coprod_{k \geq 0} \mathcal{O}_k \times_{\mathfrak{S}_k} X^k / \sim$, where \sim is the following relation. For $k \geq 0$, $\alpha \in \{0, \dots, k\}$, $a \in \mathcal{O}_k$ and $x_\alpha \in X$ let $s_\alpha(a) = \gamma(a; \mathbf{1}_\alpha)$ while we set $\mathbf{1}_\alpha = (\mathbf{1}^\alpha, *, \mathbf{1}^{k-\alpha-1})$ from $\mathcal{O}_1^\alpha \times \mathcal{O}_0 \times \mathcal{O}_1^{k-\alpha-1}$ and $t_\alpha(x_1, \dots, x_{k-1}) = (x_1, \dots, x_{\alpha-1}, x_*, x_\alpha, \dots, x_{k-1})$ from X^k . Then $(s_\alpha(a); x_1, \dots, x_{k-1}) \sim (a; t_\alpha(x_1, \dots, x_{k-1}))$.

Now we are in a position to state the following theorem from [51] in order to show that $\mathcal{S}_{\infty, 1, \partial}^+(BG)$ is an infinite loop space.

Theorem 3.1.11 ([51]). *The group completion $\mathcal{G}X$ is homotopy equivalent to an infinite loop space for every \mathcal{M} -space X .*

The space $\mathcal{M}(\ast)$ is the monoid $\mathcal{M}_0 = \coprod_{g \geq 0} B\Gamma_{g, 1}$. The monoid product is given by the pair-of-pants product (see [51]).

Proposition 3.1.12. *For every connected and compact Lie group G , the operad of Riemann surfaces \mathcal{M} acts on $\mathcal{S}_{1, \partial}(BG) = \coprod_{g \geq 0} \mathcal{S}_{g, 1, \partial}(BG)$.*

Note that \mathcal{M} carries the same data as $\mathcal{S}_{1, \partial}(BG)$ except that for each element of $\mathcal{S}_{1, \partial}(BG)$ we have a continuous map from the surface to the background space BG satisfying certain boundary conditions. In fact, this continuous map codifies the flat G -bundle structure.

As a consequence of Corollary 3.1.6 and Proposition 3.1.12 the following result is satisfied.

Corollary 3.1.13. *For every connected, compact and semisimple Lie group G , the induced map $\mathbb{Z} \times \mathfrak{P}_{\infty, \partial}^+(G) \rightarrow \Omega^\infty(\mathbb{C}P_{-1}^\infty \wedge BG_+)$ is a weak homotopy equivalence.*

It remains to prove Proposition 3.1.12.

Proof. The space $\mathcal{S}_{1,\partial}(BG)$ is a topological monoid whose product is induced by the pair-of-pants product. More precisely, let $[X_j, (a_j, b_j), \varphi_j, f_j]$ be an element from $\mathcal{S}_{g_j,1,\partial}(BG)$ for $j = 1, 2$. The product of $[X_1, (a_1, b_1), \varphi_1, f_1]$ and $[X_2, (a_2, b_2), \varphi_2, f_2]$ is defined as follows. We consider a pair-of-pants \hat{P} embedded into $\mathbb{R}^3 \times [0, 1] \subseteq \mathbb{R}^\infty \times [0, 1]$ so that $\partial_0 \hat{P} = \partial_{in} \hat{P}$ and $\partial_{out} \hat{P} = \partial_1 \hat{P} \cup \partial_2 \hat{P}$. The surface X_j is embedded in $\mathbb{R}^\infty \times [a_j, b_j]$ for $a_j < b_j$ and $j = 1, 2$. We set $l = \max_j \{b_j - a_j\}$. Then we write $a = \min_j \{a_j | l = b_j - a_j\}$ and $b = b_j$ if $a = a_j$. We glue a cylinder $S^1 \times [a_j - (l - b_j + a_j), a_j]$ to the boundary component $\partial_0 X_j$ as described in the beginning of this section. If $l = b_j - a_j$ then we do not glue any cylinder. Then translate these new surfaces \hat{X}_j for $j = 1, 2$ so that both are embedded in $\mathbb{R}^\infty \times [a, b]$. The parameterizations of the boundary $\hat{\varphi}_j$ of $\partial \hat{X}_j$ are defined by means of φ_j while f_j is extended onto the cylinders constantly by p_0 to a map \hat{f}_j . Then translate \hat{P} so that it is embedded into $\mathbb{R}^\infty \times [a - 1, a]$. Finally, $\partial_0 \hat{X}_j$ is glued to $\partial_j \hat{P}$ using $\hat{\varphi}_j$. The resulting surface X is of genus $g_1 + g_2$ with one boundary component and embedded in $\mathbb{R}^\infty \times [a - 1, b]$. Moreover, we define $f : X \rightarrow BG$ by $f|_{\hat{X}_j} = \hat{f}_j$ for $j = 1, 2$ and $f|_{\hat{P}} = p_0$. Then f is well-defined as $\hat{f}_j|_{\partial \hat{X}_j} = p_0$.

Next we make the action of \mathcal{M} on $\mathcal{S}_{1,\partial}(BG)$ precise. Let (Y, η) be a representative of an equivalence class from \mathcal{M}_k , that is, a surface Y of genus g with $k + 1$ boundary components for which a parameterization η is fixed. There is an embedding of Y into $\mathbb{R}^\infty \times [0, c]$ for some $c > 0$ such that the distinguished boundary component $\partial_0 Y$ lies in $\mathbb{R}^\infty \times \{0\}$. Note that the number $c > 0$ is determined uniquely by Y (see the construction of \mathcal{M} in Example 3.1.9). Let $[X_j, (a_j, b_j), \varphi_j, f_j] \in \mathcal{S}_{1,\partial}(BG)$ for $1 \leq j \leq k$. Again we set $l = \max_j \{b_j - a_j\}$. Moreover, we write $a = \min_j \{a_j | l = b_j - a_j\}$ and $b = b_j$ if $a = a_j$. As in the previous construction, we glue to each boundary

component $\partial_0 X_j$ the cylinder $S^1 \times [a_j - (l - b_j + a_j), a_j]$ by means of φ_j and translate these so that all surfaces are embedded in $\mathbb{R}^\infty \times [a, b]$. These new surfaces \hat{X}_j admit parameterizations of the boundary $\hat{\varphi}_j$ determined by φ_j . We define maps $\hat{f}_j : \hat{X}_j \rightarrow BG$ by extending f_j constantly onto the cylinders for all $1 \leq j \leq k$. Finally, we translate Y so that $\partial_{out} Y \subseteq \mathbb{R}^\infty \times \{a\}$ and $\partial_0 Y \subseteq \mathbb{R}^\infty \times \{a - c\}$. Then \hat{X}_j is glued to Y by identifying $\partial_0 \hat{X}_j$ with $\partial_j Y$ using the fixed parameterizations. We obtain a new surface X' of genus $g + g_1 + \dots + g_k$ with one boundary component embedded in $\mathbb{R}^\infty \times [a - c, b]$. Moreover, define a map $f' : X' \rightarrow BG$ by $f'|_{\hat{X}_j} = \hat{f}_j$ and $f'|_Y = p_0$. It is well-defined as $\hat{f}_j|_{\partial \hat{X}_j} = p_0$.

Since the connected sum along the boundary is associative (see e.g. Section 2.3 of [24]) condition (OS1) of Definition 3.1.10 follows. By construction of the unit element of \mathcal{M} it is a direct consequence that (OS2) is satisfied. It remains to verify (OS3). For this let $\sigma \in \mathfrak{S}_k$ and let Y_σ be the surface which arises from Y by permuting the index set of the boundary components $\partial_1 Y, \dots, \partial_k Y$ by means of σ . We explained the action of the symmetric group on \mathcal{M} in Example 3.1.9. Let $[X', (a', b'), \varphi', f']$ be the element of $\mathcal{S}_{1,\partial}(BG)$ by gluing X_1, \dots, X_k to Y_σ as described above. On the other hand, let $[X'', (a'', b''), \varphi'', f'']$ be the element of $\mathcal{S}_{1,\partial}(BG)$ which is constructed by gluing $X_{\sigma^{-1}(1)}, \dots, X_{\sigma^{-1}(k)}$ to Y . It follows from the construction that $[X', (a', b'), \varphi', f'] = [X'', (a'', b''), \varphi'', f'']$ as $f'|_{\hat{X}_j} = f_j = f''|_{\hat{X}_{\sigma^{-1}(j)}}$ and X' as well as X'' are of the same diffeomorphism type having one boundary component.

So there is an operad action of \mathcal{M} on $\mathcal{S}_{1,\partial}(BG)$ and the assertion follows. □

In fact, it is possible to show that $\mathfrak{B}_{\infty,\partial}^+(G)$ is weakly homotopy equivalent to an infinite loop space by using an analogous method as in Theorem 3.1.11.

For the natural generalization of Definition 2.2.8, namely the space of non-degenerated parallel slit domains of genus $g \geq 0$ with $n \geq 1$ dipole points $\mathfrak{P}_{g,n}(G)$, it was shown in [11] that $\mathcal{P}_n = \coprod_{g \geq 0} \mathfrak{P}_{g,n+1}$ is an operad. On the other hand, by means of the Hilbert uniformization there is a homotopy equivalence $\mathfrak{P}_{g,n+1} \rightarrow B\Gamma_{g,n+1}$. This map defines a homotopy equivalence of spaces $\coprod_{g \geq 0} \mathfrak{P}_{g,n+1} \rightarrow \coprod_{g \geq 0} B\Gamma_{g,n+1}$ which determines a homotopy equivalence $\mathcal{P}_n \rightarrow \mathcal{M}_n$ respecting the monoid products. Hence, there is an equivalence of operads $\mathcal{P} \rightarrow \mathcal{M}$ and the ideas of [51] can be transferred to \mathcal{P} in the sense that \mathcal{P} detects infinite loop spaces. More precisely, the theorem analogous to 3.1.11 holds for \mathcal{P} . Consequently, we have the following corollary.

Corollary 3.1.14. *Let G be a connected, compact and semisimple Lie group. Then $H_*(\mathfrak{P}_{\infty,\partial}(G); \mathbb{F}_p)$ and $H_*(\mathcal{S}_{\infty,1,\partial}(BG); \mathbb{F}_p)$ are isomorphic Pontryagin rings as algebras over the Dyer–Lashof algebra.*

For a description of the Dyer–Lashof algebra see Definition 5.5 of [21]. In view of Corollary 3.1.14, it is sufficient to construct explicit Dyer–Lashof operations for $\mathcal{S}_{\infty,1,\partial}(BG)$ in order to show that there are homology operations on the stable space of parallel slit domains $\mathfrak{P}_{\infty,\partial}(G)$. For the following construction we generalize methods from [16].

Let $\Gamma_{g,n+1}$ be the mapping class group of a compact, connected, oriented surface F of topological type $F_{g,n+1}$. The boundary components of F are labeled as above by means of a fixed parameterization. There is an induced map $\Gamma_{g,n+1} \rightarrow \Gamma_{g+1,n+1}$ by attaching a torus T with two boundary components $\partial_0 T$ and $\partial_1 T$ to any such surface F and extending every orientation preserving diffeomorphism to T by the identity. As described before, $\partial_1 T$ is identified with the boundary component $\partial_0 F$ by fixing collars of the boundary and using the fixed parameterization. Since we discussed this construction in the beginning of this section we omit any further details. Now this

map of mapping class groups defines a continuous map of their classifying spaces which is equivariant under the action of the cyclic group C_n . It acts on $B\Gamma_{g,n+1}$ by cyclically permuting the index set of the n boundary components $\partial_1 F, \dots, \partial_n F$ (see Example 3.1.9). This induces a C_n -equivariant map $\mathcal{S}_{g,n+1,\partial}(BG) \rightarrow \mathcal{S}_{g+1,n+1,\partial}(BG)$. Indeed, as was shown in the construction of $\mathcal{S}_{g,n,\partial}(BG)$, the cyclic group C_n acts on $\mathcal{S}_{g,n+1,\partial}(BG)$ by cyclically permuting the index set of the n boundary components $\partial_1 X, \dots, \partial_n X$ for any element $[X, (a, b), \varphi, f] \in \mathcal{S}_{g,n+1,\partial}(BG)$. Further, there is a map $\mathcal{S}_{g,1,\partial}(BG)^p \rightarrow \mathcal{S}_{pg,\partial}(BG)$ for all $p \geq 1$ by gluing p surfaces of genus g to a sphere with p boundary components and then extending the classifying maps constantly. The cyclic group C_p acts on $\mathcal{S}_{g,1,\partial}(BG)^p$ by permuting the entries of each p -tuple. Then $\mathcal{S}_{g,1,\partial}(BG)^p \rightarrow \mathcal{S}_{pg,\partial}(BG)$ is C_p -equivariant and there is a continuous map

$$\theta : EC_p \times_{C_p} \mathcal{S}_{g,1,\partial}(BG)^p \rightarrow \mathcal{S}_{pg,\partial}(BG).$$

For the rest of this section we assume all homology groups and chain complexes with \mathbb{F}_p -coefficients. The cyclic group C_p is a subgroup of the symmetric group \mathfrak{S}_p of index $(p-1)!$. As $(p-1)!$ is coprime to p it is invertible in \mathbb{F}_p . Consequently, there is the following map of \mathbb{F}_p -complexes which is defined by the transfer map:

$$\vartheta : C_*(E\mathfrak{S}_p) \otimes_{\mathfrak{S}_p} C_*(\mathcal{S}_{g,1,\partial}(BG))^{\otimes p} \rightarrow C_*(EC_p) \otimes_{C_p} C_*(\mathcal{S}_{g,1,\partial}(BG))^{\otimes p}.$$

Note that we identify BC_p with $E\mathfrak{S}_p/C_p$ and $B\mathfrak{S}_p$ with the quotient $E\mathfrak{S}_p/\mathfrak{S}_p$. For details on the transfer map see Section III.9 of [15]. The

continuous map θ defines a map of chain complexes

$$\theta' : C_*(EC_p) \otimes_{C_p} C_*(\mathcal{S}_{g,1,\partial}(BG))^{\otimes p} \rightarrow C_*(\mathcal{S}_{pg,\partial}(BG)). \quad (3.3)$$

Let W_* be the standard free minimal resolution of the cyclic group C_p (see Section I.5 of [15]). It follows from Section II of [21] that for every subgroup H of \mathfrak{S}_p , free H -complex V and every space M there is an isomorphism

$$H_*(V \otimes_H H_*(M)^{\otimes p}) \cong H_*(V \otimes_H C_*(M)^{\otimes p}).$$

Consequently, we have the following commutative diagram

$$\begin{array}{ccc} H_*(W_* \otimes_{C_p} C_*(\mathcal{S}_{g,1,\partial}(BG))^{\otimes p}) & \longrightarrow & H_*(\mathcal{S}_{pg,\partial}(BG)) \\ & \cong \uparrow & \uparrow \cong \\ H_*(W_* \otimes_{C_p} H_*(\mathcal{S}_{g,1,\partial}(BG))^{\otimes p}) & & H_*(\mathcal{S}_{pg,1,\partial}(BG)) \end{array}$$

where the right vertical arrow is an isomorphism for $2* \leq gp - 4$ by the stability theorem 3.1.4 from [18] and [19]. The top arrow is defined by θ' of (3.3) and a morphism of C_p -complexes $W_* \rightarrow C_*(E\mathfrak{S}_p)$ which exists because of the minimality of W_* (see [40]). Thus, we obtain the so-called *Dyer–Lashof operations*

$$Q_i : H_q(\mathcal{S}_{g,1,\partial}(BG); \mathbb{F}_p) \rightarrow H_{pq+i}((\mathcal{S}_{pg,1,\partial}(BG)); \mathbb{F}_p)$$

defined by $Q_i(x) = \bar{\theta}_*(e_i \otimes x^{\otimes p})$ where e_i is the generator of W_* in dimension i and $\bar{\theta}_*$ is the composition of the two maps

$$\begin{aligned} H_*(W_* \otimes_{C_p} H_*(\mathcal{S}_{g,1,\partial}(BG))^{\otimes p}) &\cong H_*(W_* \otimes_{C_p} C_*(\mathcal{S}_{g,1,\partial}(BG))^{\otimes p}) \\ &H_*(W_* \otimes_{C_p} C_*(\mathcal{S}_{g,1,\partial}(BG))^{\otimes p}) \rightarrow H_*(\mathcal{S}_{pg,1,\partial}(BG)). \end{aligned}$$

As was previously mentioned analogous homology operations exist on $\mathfrak{P}_{\infty, \partial}(G)$. In the next step, we will show that these stable operations commute with the Dyer–Lashof operations of the stable moduli space of Riemann surfaces.

Proposition 3.1.15. *The Dyer–Lashof operations $\{Q_i\}$ commute with the canonical projection $\mathcal{S}_{\infty, 1, \partial}^+(BG) \rightarrow B\Gamma_{\infty, 1}^+$, where in each case the plus construction is taken with respect to the fundamental groups.*

Proof. To verify the proposition we have to show that the diagram

$$\begin{array}{ccc}
C_*(E\mathfrak{S}_p) \otimes_{\mathfrak{S}_p} C_*(\mathcal{S}_{g, 1, \partial}(BG))^{\otimes p} & \longrightarrow & C_*(E\mathfrak{S}_p) \otimes_{\mathfrak{S}_p} C_*(B\Gamma_{g, 1})^{\otimes p} \\
\downarrow \vartheta & & \downarrow tr \\
C_*(EC_p) \otimes_{C_p} C_*(\mathcal{S}_{g, 1, \partial}(BG))^{\otimes p} & \longrightarrow & C_*(EC_p) \otimes_{C_p} C_*(B\Gamma_{g, 1})^{\otimes p} \\
\downarrow \theta' & & \downarrow \\
C_*(\mathcal{S}_{pg, \partial}(BG)) & \longrightarrow & C_*(B\Gamma_{pg})
\end{array}$$

is commutative. Since $\Gamma_{g, 1}$ is a group it holds that $C_*(E\mathfrak{S}_p) \otimes_{\mathfrak{S}_p} C_*(B\Gamma_{g, 1})^{\otimes p}$ is isomorphic to $C_*(\Gamma_{g, 1} \wr \mathfrak{S}_p)$. The C_p -action of the middle row corresponds in both cases to a cyclic permutation of the boundary components. Moreover, the transfer map $tr : C_*B(\Gamma_{g, 1} \wr \mathfrak{S}_p) \rightarrow C_*B(\Gamma_{g, 1} \wr C_p)$ is split over \mathbb{F}_p . Indeed, the chain complex has \mathbb{F}_p -coefficients and $E\mathfrak{S}_p/\mathfrak{S}_p$ gets identified with $B\mathfrak{S}_p$ while $E\mathfrak{S}_p/C_p$ can be identified with BC_p . Consequently, $C_*B(\Gamma_{g, 1} \wr \mathfrak{S}_p)$ is a direct factor of $C_*B(\Gamma_{g, 1} \wr C_p)$. Each horizontal arrow is a canonical projection, that is, the forgetful map with respect to the G -structure. Thus, they commute on chain level and in particular with the split projection. Hence, the whole diagram commutes up to homotopy. □

So far we have mostly compared our results on stable moduli spaces of flat

G -bundles over Riemann surfaces with current and previous developments in this field. In particular, we focused on the comparison between the methods using parallel slit domains in contrast to surfaces with boundary components. For instance, we applied the stability results from [18] and [19] to describe $\mathfrak{P}_{g,1}(G)$ for $g \rightarrow \infty$. The infinite loop space structure of Theorem 3.1.5 and Corollary 3.1.13 is a heritage of the moduli spaces of Riemann surfaces. But as we have already mentioned this cannot be assumed from the beginning on since neither the limit of the mapping spaces $\mathfrak{Map}_{\partial}(F_{g,n}, BG)$ nor the the limit of representation varieties carry an infinite loop space structure with respect to $g \rightarrow \infty$. On the other hand, we will show in the next section that there exists a further stabilization structure coming from the structure group G for some classical families of Lie groups. More precisely, we use the fact that for example the usual inclusions of general linear groups $GL(n, \mathbb{R}) \rightarrow GL(n+1, \mathbb{R})$ induce an infinite loop space structure on $BGL(\mathbb{R})$.

3.2 Further stable structures

Let $G(k)$ be one of the classical compact, connected, semisimple Lie groups $Sp(k)$, $SU(k)$ or $Spin(k)$ ¹ for $k \geq 2$. The usual embedding of Lie groups $i_k : G(k) \rightarrow G(k+1)$ induces an embedding $\mathcal{R}i_k : \mathcal{R}_{G(k)}(X) \rightarrow \mathcal{R}_{G(k+1)}(X)$ for every connected surface X . We will analyze these maps in order to find further stable structures for the moduli spaces of flat G -bundles.

In a first step, let us review some central results from [5]. Let $\pi : E \rightarrow X$ be a principal G -bundle over a connected surface of genus g where G is a connected, compact and semisimple Lie group. We denote by $Ad(E)$ the *adjoint bundle* of E , that is, the associated vector bundle $E \times_{Ad} \mathfrak{g}$ where G acts by means of the adjoint representation Ad on its Lie algebra \mathfrak{g} . The space

¹We assume $k \geq 2$ for $Spin(1) \cong \mathbb{Z}/2$ is not connected.

of connections $\mathcal{A}(E)$ on E is an affine space on the vector space of 1-forms $\Omega^1(X, Ad(E))$. As a consequence, it is contractible. The action of the gauge group $\mathfrak{G}(E)$ on $\mathcal{A}(E)$ is in general not free. On the other hand, the group of pointed gauge transformations $\mathfrak{G}_*(E)$ acts freely on $\mathcal{A}(E)$. Moreover, the embedding $\mathcal{A}_F(E) \rightarrow \mathcal{A}(E)$ is $\mathfrak{G}_*(E)$ -equivariant. In particular, the holonomy map is $\mathfrak{G}_*(E)$ -invariant. We have shown this in Corollary 1.1.19. For all details and proofs see Chapter 2 of [5].

Recall that we have discussed the relation between holomorphic bundles and compact structure groups in the end of Section 1.1. In addition, it was shown in [5] that every connection on E determines a holomorphic connection on its complexification E^c . On the other hand, for each holomorphic G^c -principal bundle with a reduction to G there exists a unique connection on this reduced principal G -bundle. Therefore, $\mathcal{A}(E)$ can be identified with $\Omega(E^c)$, the space of holomorphic structures on E^c . Note that such a principal G -bundle depends on the reduction map. By means of Morse theoretic methods, a stratification of $\Omega(E^c)$ was constructed and the relative codimensions of the strata were calculated. For these ideas we refer to Chapter 10 of [5].

The space of flat connections is homotopy equivalent to the substratum of semistable holomorphic bundles under the identification of $\mathcal{A}(E)$ and $\Omega(E^c)$ (see [47] for a proof). By calculating the codimensions of the strata it can be shown that the inclusion $\mathcal{A}_F(E) \rightarrow \mathcal{A}(E)$ is $2(g-1)r$ -connected where $r = \min_H \{ \frac{1}{2} \dim(G/H) \mid H \leq G \}$ and H ranges over all proper, connected, compact subgroups of maximal rank. This description was given in [17]. Consequently, $\mathcal{A}_F(E)$ is a $2(g-1)r$ -connected space. The representation variety $\mathcal{R}_G(X)$ parameterizes all flat connections on a pointed principal G -bundle over X . Recall from Section 1.1 that the holonomy defines an isomorphism $\mathcal{A}_F(E)/\mathfrak{G}_*(E) \rightarrow \mathcal{R}_G(X)$. Bearing this in mind we will next prove

the following theorem.

Theorem 3.2.1. *Let G be a compact, connected, semisimple Lie group and X an oriented, compact, connected surface of genus $g \geq 2$. Then the map $B : \mathcal{R}_G(X) \rightarrow \mathfrak{Map}_*(X, BG)$ is $2(g-1)r$ -connected.*

Proof. Recall that B was introduced in Definition 3.1.2. We assume that X is closed since otherwise the assertion follows from the homotopy equivalence $G \rightarrow \Omega BG$. First note that the assumption of the theorem is satisfied for $\pi_0(\mathcal{R}_G(X)) \rightarrow \pi_0(\mathfrak{Map}_*(X, BG))$. Each connected component of the representation variety as well as the mapping space can be uniquely identified with an element from $\pi_1(G)$ while the classifying map respects these identifications. We have discussed this fact in the beginning of the previous section. Hence, it remains to show the statement for the connected component $\mathfrak{Map}_*(B\pi_1, BG)_0$ of the constant map to the identity element $e \in G$ on the one hand and the connected component $\mathcal{R}_G(X)_0$ of the trivial representation ρ_0 on the other hand. Note that $\mathcal{R}_G(X)_0$ is equal to $B^{-1}(\mathfrak{Map}_*(B\pi_1, BG)_0)$. Let $x_0 \in X$, $p_0 \in E$ be base points and $\pi : E \rightarrow X$ a topologically trivial pointed flat G -bundle. We abbreviate $\mathcal{A}_F(E)$, $\mathfrak{G}(E)$ and $\mathfrak{G}_*(E)$ by \mathcal{A}_F , \mathfrak{G} and \mathfrak{G}_* as these spaces are isomorphic on the identity component. Now we will construct a map $\mathcal{A}_F \rightarrow \mathfrak{Map}_*(X, BG)_0$ which commutes with $B \circ \text{Hol}$. This map will be an important ingredient of the proof.

The universal covering $\tilde{X} \rightarrow X$ can be considered as a pointed π_1 -principal bundle after choosing a base point $\tilde{x}_0 \in \tilde{X}_{x_0}$. Thus, there is a pointed map $\psi : X \rightarrow B\pi_1$ which lifts to a unique pointed map $\tilde{\psi} : \tilde{X} \rightarrow E\pi_1$. The map ψ induces a homotopy equivalence $\psi^* : \mathfrak{Map}_*(B\pi_1, BG) \rightarrow \mathfrak{Map}_*(X, BG)$ since X is homotopy equivalent to $B\pi_1$. We consider the trivial bundle $X \times G$. Let $A \in \mathcal{A}_F(X \times G)$ and $\rho = \text{Hol}_{(x_0, e)}(A)$. Then E_ρ is a flat bundle with induced connection form A_ρ such that $\text{Hol}_{(x_0, e)}(A_\rho) = \rho$ by Theorem

1.1.22. Thus, there exists a bundle isomorphism $f_A : X \times G \rightarrow E_\rho$ satisfying $f_{A*}(A) = A_\rho$. Let \tilde{E}_ρ be the associated bundle $E\pi_1 \times_\rho G \rightarrow B\pi_1$. The representation ρ induces a map $\tilde{\psi}_\rho : \tilde{E}_\rho \rightarrow EG$ and $\tilde{\psi}$ induces a map $\epsilon : E_\rho \rightarrow \tilde{E}_\rho$ such that the diagram

$$\begin{array}{ccccc}
 & & E_\rho & \xrightarrow{\epsilon} & \tilde{E}_\rho & \xrightarrow{\tilde{\psi}_\rho} & EG & \\
 & f_A \nearrow & \downarrow & & \downarrow & & \downarrow & \\
 X \times G & & & & & & & \\
 & \searrow pr_1 & \downarrow & & \downarrow & & \downarrow & \\
 & & X & \xrightarrow{\psi} & B\pi_1 & \xrightarrow{B\rho} & BG & \\
 & \sigma \curvearrowright & & & & & &
 \end{array} \tag{3.4}$$

commutes. The map pr_1 is the canonical projection on the first factor while σ is the zero section with respect to the identity element $e \in G$. The vertical maps are the flat G -bundle projections that were considered above. Since Diagram (3.4) commutes there is a map $\kappa : \mathcal{A}_F \rightarrow \mathfrak{Map}_*(X, EG)$ which is given by $\kappa(A) = \tilde{\psi}_\rho \circ \epsilon \circ f_A \circ \sigma$. This map is pointed for every connection form $A \in \mathcal{A}_F$ as a composition of pointed maps. As the holonomy is continuous the continuity of κ follows. For this note that ρ depends continuously on A . Hence $A \mapsto \tilde{\psi}_\rho$ and $A \mapsto f_A$ are continuous assignments. We do not discuss the geometry of \mathcal{A}_F here and instead refer to [20]. By Proposition 2.4 of [5], there exists a fibration

$$\mathfrak{Map}_*(X, G) \rightarrow \mathfrak{Map}_*(X, EG) \rightarrow \mathfrak{Map}_*(X, BG)_0. \tag{3.5}$$

Even better, Atiyah and Bott showed that \mathfrak{G}_* acts continuously on \mathcal{A}_F and $\mathcal{A}_F \rightarrow \mathcal{A}_F/\mathfrak{G}_*$ is a principal \mathfrak{G}_* -bundle. On the other hand, $\mathcal{R}_G(B\pi_1)_0$ is homeomorphic to $\mathcal{A}_F/\mathfrak{G}_*$ by Theorem 1.1.22. So Hol induces a \mathfrak{G}_* -principal bundle. Moreover, it is shown in the same Proposition of [5] that $B\mathfrak{G}_*$ is homotopy equivalent to $\mathfrak{Map}_*(X, BG)_0$. Summarizing what we have so far

from the beginning of this section and this proof, we get the commutative diagram

$$\begin{array}{ccccc}
\mathfrak{G}_* & \longrightarrow & \mathcal{A}_F & \xrightarrow{\text{Hol}} & \mathcal{R}_G(B\pi_1)_0 & (3.6) \\
\downarrow \simeq & & \downarrow \kappa & & \downarrow \psi^* \circ B \\
\mathfrak{Map}_*(X, G) & \longrightarrow & \mathfrak{Map}_*(X, EG) & \longrightarrow & \mathfrak{Map}_*(X, BG)_0.
\end{array}$$

The horizontal sequences are fibrations and ψ^* is a homotopy equivalence. Thus, κ and B have the same rank of connectivity by the five lemma. Since κ is $2(g-1)r$ -connected as mentioned in the introduction of this section we obtain the assertion.

□

Although Theorem 3.2.1 holds for general connected, compact and semisimple Lie groups we will focus on the three examples $G(k)$ what will be justified by Theorem 3.2.3. The number r and the rank of connectivity of B are calculated for these in the following example. Note that the proper, connected and compact subgroups of maximal rank of simple Lie groups are fully classified (see for instance Table 5.1 in Chapter V.7 of [46]).

Example 3.2.2.

- (1) For $G(k) = Sp(k)$ we have $r = \frac{k(k+1)}{2}$ since the proper, connected, compact subgroup of maximal rank of $Sp(k)$ is $U(k)$. Hence, B is $k(k+1)(g+1)$ -connected.
- (2) For $G(k) = SU(k)$ we have $r = k-1$ since the proper, connected, compact subgroup of maximal rank of $SU(k)$ is $SU(k-1)$. So B is $2(k-1)(g-1)$ -connected.
- (3) For $G(k) = Spin(k)$ we have $r = k-2$ for even $k \geq 8$, and $r = \frac{k-1}{2}$ for odd k since the proper, connected, compact subgroups of maximal

rank of $Spin(k)$ are $Spin(k-2) \times Spin(2)$ and $Spin(k-1)$, respectively. Then B is $2(k-2)(g-1)$ -connected for even $k \geq 8$ and $(k-1)(g-1)$ -connected for odd k . Since we are particularly interested in these values for large k we do not calculate r or the connectedness of B for even $k < 8$.

Theorem 3.2.3. *Let X be a compact, oriented and connected surface of genus $g \geq 2$, then $\mathcal{R}i_k : \mathcal{R}_{G(k)}(X) \rightarrow \mathcal{R}_{G(k+1)}(X)$ is*

- (1) $(4k-4)$ -connected for $G(k) = Sp(k)$.
- (2) $(2k-2)$ -connected for $G(k) = SU(k)$.
- (3) $(k-3)$ -connected for $G(k) = Spin(k)$.

Proof. We assume again that X is closed since otherwise the assertion follows from the classical fibrations for $G(k)$.

Let $\mathfrak{G}_*(k)$ be the pointed gauge group of principal $G(k)$ -bundles and let $\mathcal{A}_F(k)$ be the space of flat $G(k)$ -connections. The commutative Diagram (3.6) induces the commutativity of the diagram

$$\begin{array}{ccc}
 B\mathfrak{G}_*(k) & \xrightarrow{Bj_k} & B\mathfrak{G}_*(k+1) & (3.7) \\
 \cong \uparrow & & \uparrow \cong & \\
 \mathfrak{Map}_*(X, BG(k))_0 & \xrightarrow{(Bi_k)_*} & \mathfrak{Map}_*(X, BG(k+1))_0 & \\
 \uparrow & & \uparrow & \\
 \mathfrak{Map}_*(X, EG(k)) & \xrightarrow{(Ei_k)_*} & \mathfrak{Map}_*(X, EG(k+1)) & \\
 \kappa_k \uparrow & & \uparrow \kappa_{k+1} & \\
 \mathcal{A}_F(k) & \xrightarrow{\alpha_k} & \mathcal{A}_F(k+1) & \\
 \text{Hol} \downarrow & & \downarrow \text{Hol} & \\
 \mathcal{R}_{G(k)}(X)_0 & \xrightarrow{\mathcal{R}i_k} & \mathcal{R}_{G(k+1)}(X)_0 &
 \end{array}$$

The maps $(Bi_k)_*$, $(Ei_k)_*$ and $\mathcal{R}i_k$ are induced by i_k . Moreover, κ_k and κ_{k+1} are the maps κ in Diagram (3.6) in dimensions k and $k+1$, respectively. In other words, κ_k and κ_{k+1} are the maps which were constructed in the proof of Theorem 3.2.1. Since every $G(k)$ -principal bundle determines a $G(k+1)$ -principal bundle there are induced maps Bj_k from the natural inclusion $j_k : \mathfrak{G}_*(k) \rightarrow \mathfrak{G}_*(k+1)$ and α_k . The unlabeled vertical maps arise from the fibration (3.5). The rank of connectivity of $\mathcal{A}_F(k)$ follows in each of the three cases from Example 3.2.2, namely $\mathcal{A}_F(k)$ is

- (1) $k(k+1)(g-1)$ -connected for $Sp(k)$.
- (2) $2(k-1)(g-1)$ -connected for $SU(k)$.
- (3) $2(k-2)(g-1)$ -connected for even $k \geq 8$ and $Spin(k)$.
- (4) $(k-1)(g-1)$ -connected for odd k and $Spin(k)$.

The horizontal sequences in (3.6) are fibrations. As a consequence of (3.7), the map $\mathcal{A}_F(k) \rightarrow B\mathfrak{G}_*(k)$ is equally connected as stated in the previous enumeration. Since $g \geq 2$, the lower bounds of connectivity are given by

- (1) $k(k+1)$ for $Sp(k)$.
- (2) $2(k-1)$ for $SU(k)$.
- (3) $2(k-2)$ for even $k \geq 8$ and $Spin(k)$.
- (4) $(k-1)$ for odd k and $Spin(k)$.

Because of the fibrations of Lie groups $G(k) \rightarrow G(k+1)$ we have that

- (1) $Sp(k) \rightarrow Sp(k+1)$ is $(4k-3)$ -connected.
- (2) $SU(k) \rightarrow SU(k+1)$ is $(2k-1)$ -connected.

(3) $Spin(k) \rightarrow Spin(k+1)$ is $(k-2)$ -connected.

See for example Section II.3 of [46] for these numbers. We remind of the classical fact from homotopy theory that for any k -connected map of CW-complexes $f : M \rightarrow N$ and finite d -dimensional CW-complex Z the induced map $\mathfrak{M}ap_*(Z, M) \rightarrow \mathfrak{M}ap_*(Z, N)$ is $(k-d)$ -connected. As X is a 2-dimensional CW-complex, $\mathfrak{M}ap_*(X, BG(k))_0 \rightarrow \mathfrak{M}ap_*(X, BG(k+1))_0$ is

(1) $(4k-4)$ -connected for $Sp(k)$.

(2) $(2k-2)$ -connected for $SU(k)$.

(3) $(k-3)$ -connected for $Spin(k)$.

Since $4k-4 \leq k(k+1)$, $2k-2 \leq 2(k-1)$ and $k-3 \leq \min_k\{2(k-2), k-1\}$ for all $k \geq 0$ these numbers determine lower connectivity bounds. As Diagram (3.7) commutes the maps $\mathcal{R}i_k$ realize these degrees of connectivity.

□

Corollary 3.2.4. *Let $\mathop{\mathrm{hocolim}}_k \mathcal{R}_{G(k)}(X) = \mathcal{R}_\infty^G(X)$ for $G(k)$ being one of the classical families of connected, compact, semisimple Lie groups $Sp(k)$, $SU(k)$ or $Spin(k)$. The homotopy groups of $\mathcal{R}_\infty^G(X)$ are as follows.*

(1)

$$\pi_q(\mathcal{R}_\infty^{Sp}(X)) \cong \begin{cases} \mathbb{Z}, & q \equiv 0 \pmod{8} \\ 0, & q \equiv 1, 2 \pmod{8} \\ \mathbb{Z}^{2g}, & q \equiv 3, 7 \pmod{8} \\ (\mathbb{Z}/2)^{2g} \times \mathbb{Z}, & q \equiv 4 \pmod{8} \\ (\mathbb{Z}/2)^{2g+1}, & q \equiv 5 \pmod{8} \\ \mathbb{Z}/2, & q \equiv 6 \pmod{8}. \end{cases}$$

(2)

$$\pi_q(\mathcal{R}_\infty^{SU}(X)) \cong \begin{cases} \mathbb{Z}, & q \equiv 0 \pmod{2} \\ \mathbb{Z}^{2g}, & q \equiv 1 \pmod{2}. \end{cases}$$

(3)

$$\pi_q(\mathcal{R}_\infty^{Spin}(X)) \cong \begin{cases} (\mathbb{Z}/2)^{2g} \times \mathbb{Z}, & q \equiv 0 \pmod{8} \\ (\mathbb{Z}/2)^{2g+1}, & q \equiv 1 \pmod{8} \\ \mathbb{Z}/2, & q \equiv 2 \pmod{8} \\ \mathbb{Z}^{2g}, & q \equiv 3, 7 \pmod{8} \\ \mathbb{Z}, & q \equiv 4 \pmod{8} \\ 0, & q \equiv 5, 6 \pmod{8}. \end{cases}$$

Proof. The lower bound for q is calculated in Theorem 3.2.3. We have the homotopy equivalence $\mathop{hocolim}_k \mathcal{R}_{G(k)}(X) \simeq \mathop{hocolim}_k \mathfrak{Map}_*(X, BG(k))$ from Theorem 3.2.1. Moreover, $\mathop{hocolim}_k \mathfrak{Map}_*(X, BG(k))$ is homotopy equivalent to $\mathfrak{Map}_*(X, BG(\infty))$. Applying the cell decomposition of X as a CW-complex it follows that $\mathfrak{Map}_*(X, BG(\infty))$ has the same homotopy type as $\mathbb{Z} \times G(\infty)^{2g} \times BG(\infty)$. For $Sp(k)$, $SU(k)$ and $Spin(k)$ Bott periodicity is satisfied and the results follow. See for example Table 4.1 in IV.6 of [46] for an explicit calculation of the stable homotopy groups of these Lie groups by means of Bott periodicity. □

Using this corollary and Lemma 1.2.8 we may determine (see Corollary 3.2.5) the stable homotopy groups of the homotopy colimit $\mathop{hocolim}_k \mathcal{M}_{g,1}(G(k))$ which we note as $\mathcal{M}_{g,1}^{G,\infty}$.

This limit is defined by identifying $\mathcal{M}_{g,1}(G(k))$ with $E\Gamma_{g,1} \times_{\Gamma_{g,1}} \mathcal{R}_{G(k)}(S_{g,1})$

(see Lemma 1.2.8). Then $\mathcal{M}_{g,1}(G(k)) \rightarrow \mathcal{M}_{g,1}(G(k+1))$ is defined by

$$I_k : E\Gamma_{g,1} \times_{\Gamma_{g,1}} \mathcal{R}_{G(k)}(S_{g,1}) \longrightarrow E\Gamma_{g,1} \times_{\Gamma_{g,1}} \mathcal{R}_{G(k+1)}(S_{g,1})$$

which is induced by $\mathcal{R}i_k$. The map I_k is well-defined since $\mathcal{R}i_k$ commutes with the $\Gamma_{g,1}$ -action. To this end, let $[f] \in \Gamma_{g,1}$, $\rho \in \mathcal{R}_{G(k)}(S_{g,1})$ and $\gamma \in \pi_1(S_{g,1})$. Then $[f] \cdot \mathcal{R}i_k(\rho)(\gamma) = \mathcal{R}i_k(\rho)(f_*^{-1}(\gamma)) = \begin{pmatrix} \rho(f_*^{-1}(\gamma)) & 0 \\ 0 & 1 \end{pmatrix} = \begin{pmatrix} [f] \cdot \rho(\gamma) & 0 \\ 0 & 1 \end{pmatrix} = \mathcal{R}i_k([f] \cdot \rho)(\gamma)$. For this calculation we use the fact that $G(k)$ is linear algebraic so that every element of $G(k)$ is canonically representable as a matrix.

Corollary 3.2.5. *The stable homotopy groups of $\mathcal{M}_{g,1}^{G,\infty}$ are given by the results of Corollary 3.2.4 for $q \geq 2$ in the stated ranges. In particular, the homotopy groups $\pi_q(\mathcal{M}_{g,1}(G(k)))$ are independent of k for $q \geq 2$ and*

- (1) $q \leq 4k - 4$ for $G(k) = Sp(k)$.
- (2) $q \leq 2k - 2$ for $G(k) = SU(k)$.
- (3) $q \leq k - 3$ for $G(k) = Spin(k)$.

Remark 3.2.6. The bounds for the maps $\mathcal{R}i_k$ of Example 3.2.2 are optimal in each case in the sense that they are not higher connected. To see this, we consider $\pi_q(Bi_k)$ because of the commutativity of Diagram (3.7). These maps are not surjective for $q = 4k - 3$, $q = 2k - 1$ and $q = k - 2$ in the case of $Sp(k)$, $SU(k)$ and $Spin(k)$, respectively. Since by assumption X is a closed surface its CW-decomposition induces the homotopy fiber sequence

$$\Omega^2 BG(k) \longrightarrow \mathfrak{M}ap_*(X, BG(k)) \longrightarrow (\Omega BG(k))^{2g}.$$

More precisely, the right map of the sequence is defined by restricting the

based maps from X to $BG(k)$ to the 1-skeleton of X . This homotopy fiber sequence defines a long exact sequence of homotopy groups. By V.6 of [46], $\pi_{4k-2}(Sp(k))$, $\pi_{4k-1}(Sp(k))$, $\pi_{2k}(SU(k))$, $\pi_{2k+1}(SU(k))$, $\pi_{k-1}(Spin(k))$ and $\pi_k(Spin(k))$ are not torsionfree. In 6.14 of Chapter V of [46] these homotopy groups are explicitly calculated. In particular, it follows that $\pi_q(Bi_k)$ is not surjective, and consequently nor is the map $\pi_q(\mathcal{R}i_k)$.

Bibliography

- [1] J. ABHAU, C.-F. BÖDIGHEIMER, R. EHRENFRIED: Homology computations for mapping class groups and moduli spaces of surfaces with boundary, *Geometry and Topology Monographs* **14**, 1-25 (2008)
- [2] J. F. ADAMS: Infinite loop spaces, *Princeton University Press, Annals of Math. Studies* **90** (1978)
- [3] A. ADEM, F. R. COHEN: Commuting elements and spaces of homomorphisms, *Math. Ann.* **338**, 587-626 (2007)
- [4] E. G. ANDREWS: The theory of partitions, *Encyclopedia of Mathematics and its Applications* **2** (1976)
- [5] M. F. ATIYAH, R. BOTT: The Yang-Mills equations over Riemann surfaces, *Philos. Trans. Roy. Soc. London Ser. A* **308**, 523-615 (1983)
- [6] H. BAUM: Eichfeldtheorie, *Springer-Verlag*(2009)
- [7] L. BERS: Uniformization, moduli, and Kleinian groups, *Bull. London Math. Soc.* **4**, 257-300 (1972)
- [8] J. S. BIRMAN: Braids, links, and mapping class groups, *Princeton University Press, Annals of Math. Studies* **82** (1974)
- [9] C.-F. BÖDIGHEIMER: On the topology of moduli spaces, part I: Hilbert Uniformization, *Math. Gott.* **7+8** (1990)
- [10] C.-F. BÖDIGHEIMER: On the topology of moduli spaces, part II: Homology Operations, *Math. Gott.* **23** (1990)
- [11] C.-F. BÖDIGHEIMER: Configuration models for moduli spaces of Riemann surfaces with boundary, *Abh. Math. Sem. Univ. Hamburg* **76**, 191-233 (2006)
- [12] C.-F. BÖDIGHEIMER: private communication, *Bonn* (2010)
- [13] A. BOREL, F. HIRZEBRUCH: Characteristic classes and homogeneous spaces I, *Amer. J. Math.* **80**, 458-538 (1958)

- [14] R. BOTT: The stable homotopy of the classical groups, *Ann. of Math.* **70**, 313-337 (1959)
- [15] K. S. BROWN: Cohomology of groups, *Springer-Verlag, Graduate Texts in Mathematics* **87** (1982)
- [16] F. R. COHEN, U. TILLMANN: Toward homology operations for mapping class groups, *Contemp. Math.* **220**, 35-46 (1998)
- [17] R. L. COHEN, S. GALATIUS, N. KITCHLOO: Universal moduli spaces of surfaces with flat bundles and cobordism theory, *Adv. Math.* **221**, 1227-1246 (2009)
- [18] R. L. COHEN, I. MADSEN: Surfaces in a background space and the homology of mapping class groups, *Proc. Sympos. Pure Math.* **80**, 43-76 (2009)
- [19] R. L. COHEN, I. MADSEN: Stability for closed surfaces in a background space, *Homology, Homotopy, and Applications* **13**, 301-313 (2011)
- [20] G. DASKALOPOULOS: The topology of the space of stable bundles on a compact Riemann surface, *Jour. of Diff. Geom.* **36**, 699-746 (1992)
- [21] E. DYER, R. K. LASHOF: Homology of iterated loop spaces, *Amer. J. Math.* **84**, 35-88 (1962)
- [22] C. J. EARLE, J. EELLS: A fibre bundle description of Teichmüller theory, *Jour. of Diff. Geom.* **3**, 19-43 (1969)
- [23] J. EBERT: Über den Modulraum mehrfach gerichteter und punktierter Kleinscher Flächen, *Diplomarbeit, Bonn* (2003)
- [24] B. FARB, D. MARGALIT: A primer on mapping class groups, *Princeton Mathematical Series* (2012)
- [25] L. D. GOÇALVES, J. GUASCHI: The braid groups of the projective plane, *Algebr. Geom. Topol.* **4**, 757-780 (2004)
- [26] W. M. GOLDMAN: Topological components of spaces of representations, *Invent. Math.* **93**, 557-607 (1988)
- [27] W. M. GOLDMAN: Ergodic theory on moduli spaces, *Ann. of Math.* **(2) 146**, 475-507 (1997)
- [28] W. M. GOLDMAN, E. Z. XIA: Rank one Higgs bundles and representations of fundamental groups of Riemann surfaces, *Mem. Amer. Math. Soc.* **193**, viii+69 pp. (2008)
- [29] P. GRIFFITHS, J. HARRIS: Principles of algebraic geometry, *John Wiley and Sons Inc.* (1978)

- [30] J. L. HARER: Stability of the homology of the mapping class groups of orientable surfaces, *Ann. of Math.* **121**, 215-249 (1985)
- [31] M. W. HIRSCH: Differential topology. Corrected reprint of the 1976 original, *Springer-Verlag, Graduate Texts in Mathematics* **33** (1992)
- [32] A. HULPKE: Constructing transitive permutation groups, *J. Symbolic Comput.* **39**, 1-30 (2005)
- [33] Y. IMAYOSHI, M. TANIGUCHI: An introduction to Teichmüller spaces, *Springer-Verlag* (1992)
- [34] S. KATOK: Fuchsian groups, *Chicago Lectures in Mathematics* (1992)
- [35] S. KOBAYASHI: Differential geometry of complex vector bundles, *Princeton University Press* (1987)
- [36] S. KOBAYASHI, K. NOMIZU: Foundations of differential geometry I, *John Wiley and Sons Inc.* (1963)
- [37] J. H. KWAK, J. LEE, A. MEDNYKH: Coverings, enumeration and Hurwitz problems, Applications of Group Theory to Combinatorics *CRC Press*, 71-107 (2008)
- [38] J. LI: The space of surface group representations, *Manuscripta Math.* **78**, 223-243 (1993)
- [39] S. LIPSCOMB: Symmetric inverse semigroups, *Mathematical Surveys and Monographs* **46** (1996)
- [40] I. MADSEN, U. TILLMANN: The stable mapping class group and QCP_+^∞ , *Invent. Math.* **145**, 509-544 (2001)
- [41] J. P. MAY: Simplicial objects in algebraic topology, *Van Nostrand Mathematical Studies* **11** (1967)
- [42] J. P. MAY: The geometry of iterated loop spaces, *Springer-Verlag, Graduate Texts in Mathematics* **271** (1972)
- [43] J. MCCLEARY: A user's guide to spectral sequences. Second edition, *Cambridge Studies in Advanced Mathematics* **58** (2001)
- [44] D. MCDUFF, G. SEGAL: Homology fibrations and the "group-completion" theorem, *Invent. Math.* **31**, 279-284 (1976)
- [45] P. W. MICHOR: Gauge theory for fiber bundles, Monographs and Textbooks in Physical Sciences *Bibliopolis, Lecture Notes* **19** (1991)
- [46] M. MIMURA, H. TODA: Topology of Lie groups, I and II, *Trans. of Math. Monographs, AMS* **91** (1978)

- [47] A. RÅDE: On the Yang-Mills heat equation in two and three dimensions, *J. Reine. Angew. Math.* **431**, 123-163 (1992)
- [48] A. RAMANATHAN: Stable principal bundles on a compact Riemann surface, *Math. Ann.* **213**, 129-152 (1975)
- [49] M. RODENHAUSEN: Links in classifying spaces of symmetric groups, *Diplomarbeit, Bonn* (2010)
- [50] U. TILLMANN: On the homotopy of the stable mapping class group, *Invent. Math.* **130**, 257-275 (1997)
- [51] U. TILLMANN: Higher genus surface operad detects infinite loop spaces, *Math. Ann.* **317**, 613-628 (2000)
- [52] J. VÄISÄLÄ: Lectures on n-dimensional quasiconformal mappings, *Springer-Verlag, Graduate Texts in Mathematics* **229** (1971)
- [53] B. VISY: Factorable groups and their homology, *Phd Thesis, Bonn* (2011)
- [54] N. WAHL: Infinite loop space structure(s) on the stable mapping class group, *Topology* **43**, 343-368 (2004)
- [55] A. R. WENTWORTH: The action of the mapping class group on representation varieties, *Adv. Lect. Math. (ALM)* **16**, 277-299 (2011)

Index

- $[\emptyset]$, 158
 $\mathbb{1}$, 174

 A , 32
 Ad , 31
 $Ad(E)$, 185
 $A(E)$, 33
 $\mathcal{A}_F(E)$, 35
 \mathcal{A}_F , 187
 $\mathcal{A}_F(k)$, 190
 A_ρ , 36
 A_v , 32

 B , 167
 $b_0(M)$, 78
 BG , 142
 $B_n(G)$, 142
 $B_n(Y, G, Z)$, 141
 $B_r(M)$, 83
 $B(Y, G, Z)$, 141

 C^* , 159
 $C + C'$, 154
 C_k , 78
 $\mathcal{C}_*(M, G)$, 40
 $\tilde{C}^r(M)$, 83
 $C^r(M)$, 83
 $C(Y)$, 150
 $c(Y)$, 160

 $\Delta[n]$, 128
 D''_j , 123
 $\partial_{in}F$, 165
 $Diff(F_{g,n})$, 79
 $Diff^m_{g,n}$, 47
 $Diff^{m,0}_{g,n}$, 47
 d'_i , 123

 d''_i , 123
 $\partial_{out}F$, 165

 \mathcal{E} , 48
 E^c , 45, 186
 EG , 141
 $E(G)$, 141
 $\mathcal{E}_{g,n,1}$, 175
 $E_n(G)$, 141
 E_ρ , 36
 $\mathcal{E}(X, \mathbb{R}^\infty)$, 166

(FC), 107
 F_g , 79
 $F_{g,n}$, 79
 $\mathcal{F}_h B(G \wr \mathfrak{S}_p)$, 142
 $\mathcal{F}_{(h)} B(G \wr \mathfrak{S}_*)$, 143
 $\mathcal{F}_{(h)} B(G \wr \mathfrak{S}_p)$, 142
 $\mathcal{F}_h E(G \wr \mathfrak{S}_p)$, 142

 \mathcal{G} , 126
 \mathfrak{g} , 31
 γ , 174
 $\Gamma(F_{g,n})$, 79
 G^c , 45
 $\mathfrak{G}(E)$, 34
 $\mathcal{G}(G)$, 125
 $(g_k : \dots : g_0)$, 142
 $G(k)$, 185
 $[g_k : \dots : g_0]$, 142
 $\mathcal{G}M$, 173
 $\Gamma^m_{g,n}$, 47

 \mathcal{H} , 126
 $\mathcal{H}(G)$, 124
 $\mathfrak{H}^m_{g,q}$, 96
 $\mathfrak{H}^m_{g,1}(G)$, 121

Hol , 36
 $\text{Hol}_v(A)$, 35
 $\mathcal{H}(\pi_1, G)$, 39
 $\mathcal{H}_*(\pi_1, G)$, 39
 $\mathcal{H}_r[K]$, 78
 $\mathcal{H}_r(X)[K]$, 78
 \hat{Y} , 109

 \mathcal{K} , 96
 $\hat{\mathcal{K}}$, 96

 L_g , 31

 \mathfrak{m} , 147
 \mathfrak{Map}_* , 167
 \mathfrak{Map}_∂ , 167
 \mathfrak{Map}_λ , 166
 $\mathcal{M}_{g,1}^{G,\infty}$, 193
 $\mathcal{M}_{g,1}^m[K]^G$, 76
 $\mathcal{M}_{g,1}^m[K]$, 76
 $\mathcal{M}_{g,1}^m[K]_0$, 76
 $\mathcal{M}_{g,1}^m[K]_0^G$, 76
 $\mathcal{M}_{g,1}^m[K]_*^G$, 76
 $\mathcal{M}_{g,1}^m[K]_*$, 76
 $\mathcal{M}_{g,n}^m$, 46, 47
 $\mathcal{M}_{g,1}^m(G)$, 48
 $\mathcal{M}_{g,n}^{(m)}$, 92
 $\mathcal{M}_{g,1}^{(m)}(G)$, 93
 \mathcal{M}_n , 177
 μ , 154

 $O(\rho)$, 81
 Ω_0 , 173
 o_1 , 52
 o_2 , 52
 $\Omega^1(E, \mathfrak{g})$, 32
 ω^* , 33
 ω_v^* , 33
 $\{\mathcal{O}_n\}_{n \geq 0}$, 174
 $\mathcal{O}(X)$, 178

 P_ω , 33
 \mathbb{P} , 104
 P_ω^A , 33

 $\text{Par}_{g,1}^m$, 104
 $\text{Par}_{g,1}^{m'}$, 105
 $\mathfrak{P}_{g,1}^m$, 105
 $PB_r(M)$, 83
 \mathfrak{p} , 123
 $\mathfrak{p}(G)$, 123
 $\mathbb{P}(G)$, 123
 $\text{Par}_{g,1}^m(G)$, 123
 $\text{Par}_{g,1}^{m'}(G)$, 123
 $\mathfrak{P}_{g,1}^m(G)$, 123
 $P_{\mathfrak{S}}(G)$, 131
 $\Pi(K)$, 78
 π_ρ , 36
 $\mathbb{P}[K]$, 124
 $\text{Par}_{g,1}^m[K]$, 124
 $\mathfrak{P}(G)$, 150
 $\mathfrak{P}_{\infty,\partial}(G)$, 170
 $\mathfrak{P}_{g,1}^m[K]$, 124
 $\text{Pot}_{g,1}^m$, 122
 $P_1 \cup_\psi P_2$, 157
 $\mathbb{P}_{p,q}$, 104
 $P_{\mathfrak{P}}(G)$, 130
 $\mathbb{P}'[K]$, 124
 $\text{Par}_{g,1}^{m'}[K]$, 124
 $\Pi_{p,q}$, 124
 $\mathbb{P}_{p,q}(G)$, 123
 $\mathbb{P}_{p,q}[K]$, 124
 PSD , 97
 PSM , 102

 (Q, χ) , 46
 Q_i , 183

 r , 186
 R_g , 31
 \mathcal{R}_G , 150
 $\mathcal{R}_G(S)$, 41
 ρ_0 , 51
 ρ_A , 36
 $R_{i,j}$, 101

 $\mathfrak{G}_*(E)$, 35
 \mathfrak{G} , 187
 $\mathcal{S}_{1,\partial}(BG)$, 178
 $\mathcal{S}_{g,n}(BG)$, 166

$\mathcal{S}_{g,n,\lambda}(BG)$, 165
 \mathfrak{G}_* , 187
 $\mathfrak{G}_*(k)$, 190
 $S.(j, \xi)$, 106
 $\mathcal{S}(M)$, 46
 $S_{g,n}^m$, 45
 $S_{g,n}^{(m)}$, 92
 \mathfrak{G}_n , 103
 \mathfrak{G}_n^0 , 103

 τ_1^* , 159
 ϑ , 177
 TH , 31
 TH_v , 31
 $\mathcal{T}_{g,n}^m$, 47
 $\mathcal{T}_{g,1}^m(G)$, 49
 $TV_v E$, 30

 u , 95
 $\mathcal{U}(G)$, 170

 v , 97
 $\mathcal{V}(G)$, 167

 w , 97
 wl , 103
 $\{W_\alpha, \phi_\alpha\}$, 100

 $x_+(Y)$, 150
 $x_-(Y)$, 150
 $\mathcal{C}(M, G)$, 40

 $y_+(Y)$, 150
 $y_-(Y)$, 150
 Y^* , 159
 $Y(C)$, 150
 Y^+ , 174
 rY , 150
 $Y + Y'$, 151
 $Y + z$, 150

 z_s^* , 159